

INSTALLATION INSTRUCTIONS

77-3058

CHEVROLET / GMC / CADILLAC

2007-08 Sierra Denali / Yukon Denali / Yukon Denali XL / Escalade

V8-6.2L

2007-08 Silverado 1500 / Sierra 1500

V8-4.8L / 5.3L / 6.0L

2007-08 Yukon XL 1500

V8-5.3L / 6.0L / 6.2L

2007-08 Tahoe / Yukon

V8-4.8L / 5.3L

2007-08 Avalanche / Suburban 1500

V8-5.3L / 6.0L

2007-09 Cheyenne 2500

V8-5.3L

NOTE: This kit was not designed to fit vehicles with a body lift.

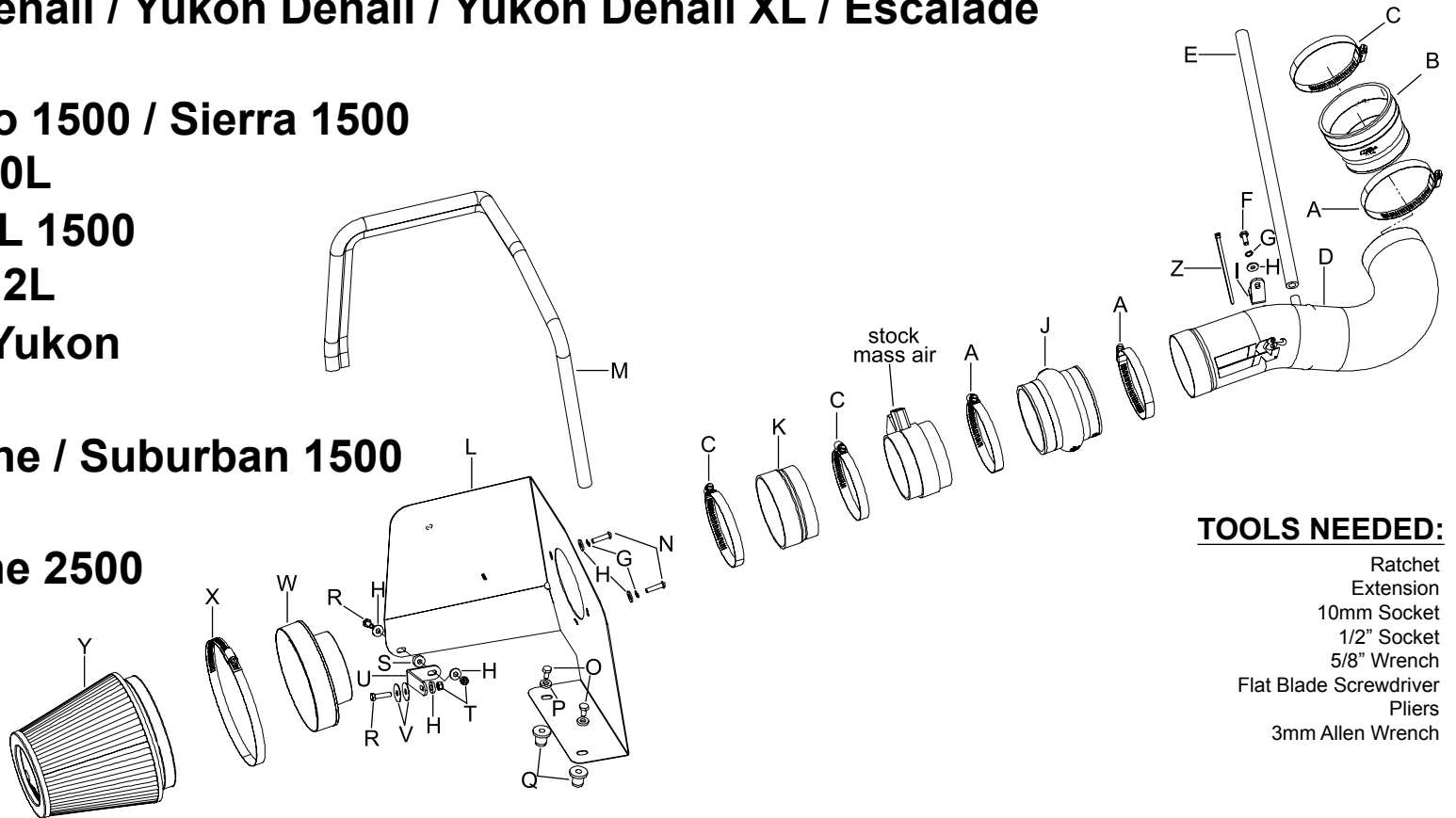

TOOLS NEEDED:

- Ratchet
- Extension
- 10mm Socket
- 1/2" Socket
- 5/8" Wrench
- Flat Blade Screwdriver
- Pliers
- 3mm Allen Wrench

PARTS LIST:

Description	Qty.	Part #	Description	Qty.	Part #	Description	Qty.	Part #
A Hose Clamp # 56	3	08620	J Hose; 3.63"ID X 3.38"L, Hump	1	08176	S Spacer; 625"ODx.250"IDx.250"L,	1	06555
B Hose; 4"ID to 3.5"ID, Tprd.	1	08050	K Hose; 4.0"IDx3.824IDx2.0"L, Tprd.	1	08618	T Nut; 6mm Nylock, Hexhead	2	07553
C Hose Clamp #60	3	08628	L Heat Shield	1	07635	U Bracket; "L" Sm., Stl., FB/PC	1	010031
D Intake Tube	1	27190	M Edge Trim 39"L	1	102496	V Washer; 1"D X 1/4 Hose Fender	2	08160
E Hose; 3/8"ID X 17"L, Silicone	1	08404	N Bolt; M6x1.00x16mm, Buttonhead	2	07730	W Adapter; #454	1	27300
F Bolt; M6-1.00 X 16mm HexHd.	1	07703	O Bolt; 5/16"- 18 X 1"L, SS	2	07777	X Hose Clamp # 104	1	08697
G Washer; 1/4" Lock, Zn.	3	08198	P Washer; 5/16"ID X 5/8"OD, Flat	2	08276	Y Air Filter	1	RF-1042
H Washer; 1/4"ID X 5/8"OD	6	08275	Q Insert; 5/16-18x.600ODx.730L	2	088002	Z Cable Ties; 3/16"W X 17"L Black	1	21592
I Bracket; L-Bend, Fin.	1	070812	R Bolt; M6-1.00 X 25mm Hex Hd.	2	07704			

NOTE: FAILURE TO FOLLOW INSTALLATION INSTRUCTIONS AND NOT USING THE PROVIDED HARDWARE MAY DAMAGE THE INTAKE TUBE, THROTTLE BODY AND ENGINE.

TO START:

1. Turn off the ignition and disconnect the negative battery cable.
NOTE: Disconnecting the negative battery cable erases pre-programmed electronic memories. Write down all memory settings before disconnecting the negative battery cable. Some radios will require an anti-theft code to be entered after the battery is reconnected. The anti-theft code is typically supplied with your owner's manual. In the event your vehicles' anti-theft code cannot be recovered, contact an authorized dealership to obtain your vehicles anti-theft code.



2. Disconnect the mass air sensor electrical connection.



3. Lift up on the front of the engine cover to disengage from the mounting grommets. Then pull forward and remove the engine cover from the engine as shown.



4. Unhook the radiator hose mount from the intake tube.



5. Disconnect crankcase vent hose from the valve cover as shown.



6. Loosen the hose clamps, which secure the stock intake tube to the throttle body and mass air sensor and then remove the intake tube from the vehicle.



7. Pull firmly upwards to release the air cleaner assembly from the mounting tray grommets, and then remove the assembly as shown.

NOTE: K&N Engineering, Inc., recommends that customers do not discard factory air intake.



8. Loosen the hose clamp and remove the mass air sensor from the air cleaner as shown.



9. Install the filter adapter onto the heat shield and secure with the provided hardware.

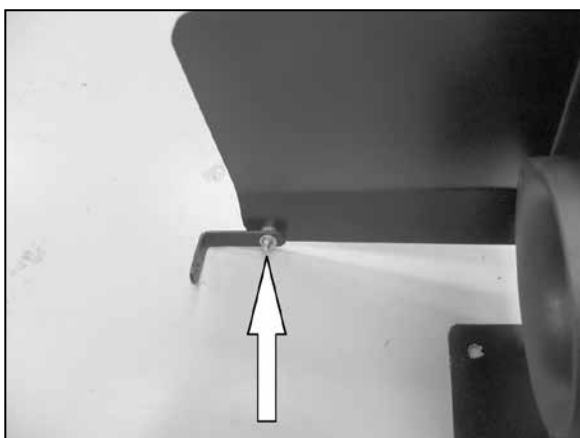

10. Install the "L" bracket (010031) onto the heat shield with the provided hardware as shown.



11. Install the provided edge trim onto the heat shield as shown.

NOTE: Some trimming of the edge trim may be necessary.

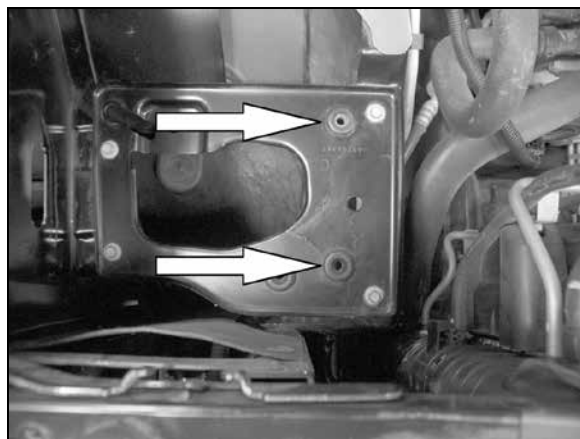

12. Remove the two air box mounting grommets shown.

NOTE: Some vehicles may not be equipped with the front grommet and hole. Go to step #12a.

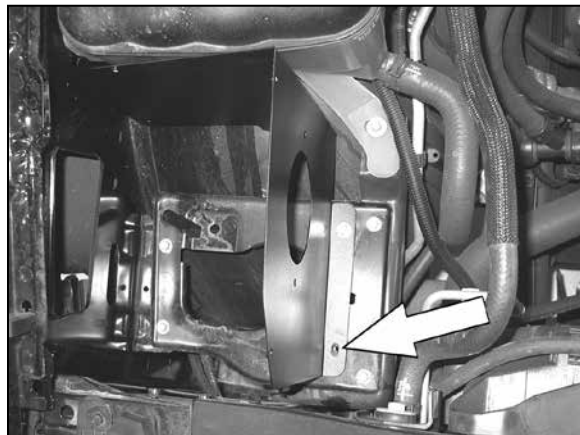

12a. On vehicles that are not equipped with the front airbox mounting grommet and hole, install the heat shield assembly as shown. Then, use a marker to mark the mounting plate through the heat shield mounting hole.

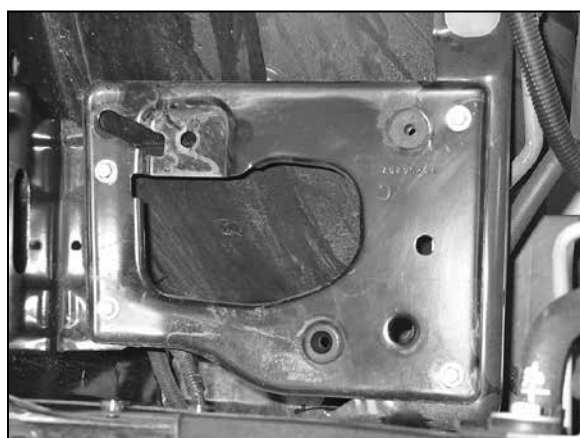

12b. Remove the heat shield assembly and drill a 5/8" hole through the marked location from step #12a.

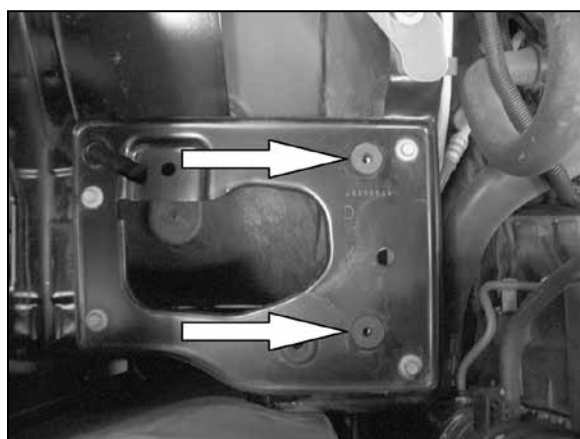

13. Install the two 5/16" inserted nuts into the airbox mounting tray as shown.

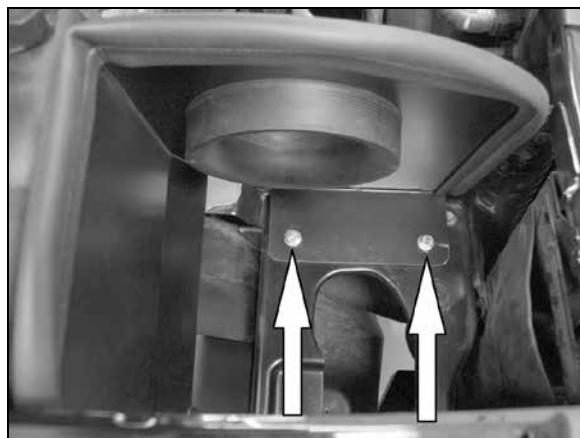

14. Install the heat shield assembly onto the airbox mounting tray and secure to the 5/16" inserted nuts with the provided hardware as shown.

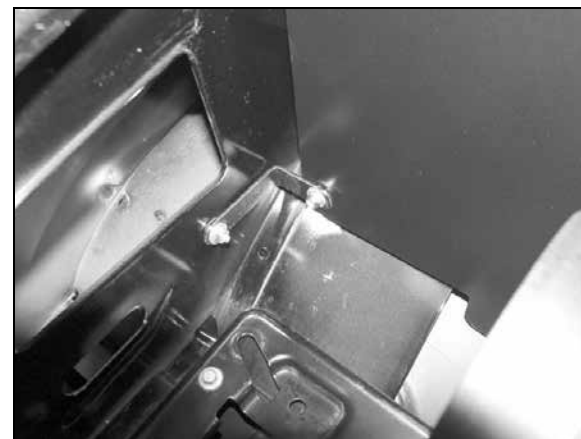

15. Secure the heat shield mounting bracket to the inner fender with the fender washers and hardware as shown.



16. Install the silicone hose (08618) onto the filter adapter and secure with the provided hose clamp.



17. Install the silicone (08050) hose onto the throttle body and secure with the provided hose clamp.

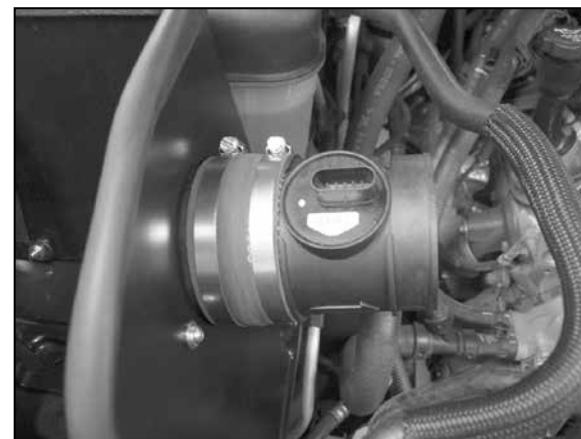

18. Install the mass air sensor assembly into the silicone hose on the filter adapter and secure with provided hose clamp.



19. Install the silicone hump hose (08176) onto the K&N® intake tube and secure with the provided hose clamp as shown.

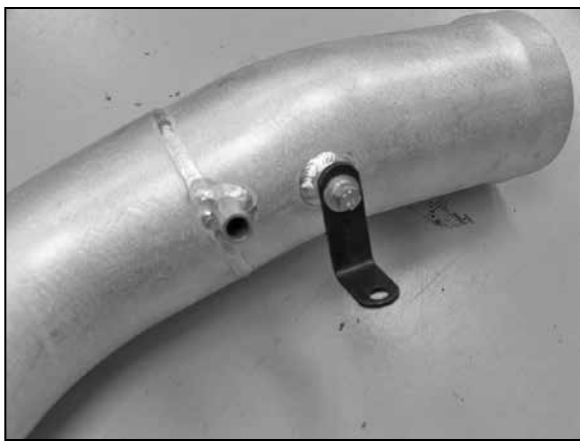

20. Install the "L" bracket (070812) onto the K&N® intake tube with the provided hardware as shown.

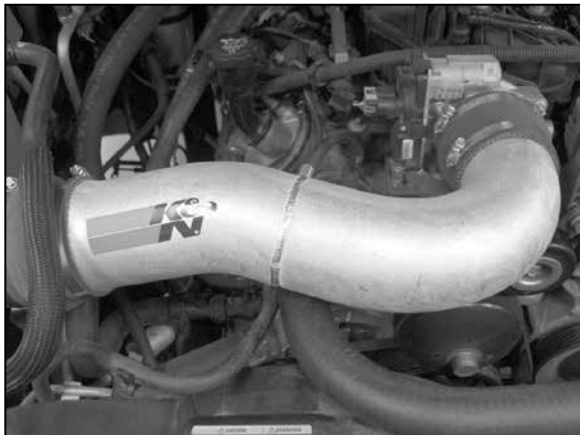

21. Install the K&N® intake tube into the silicone hose at the throttle body and mass air sensor and secure it with the provided hose clamps.

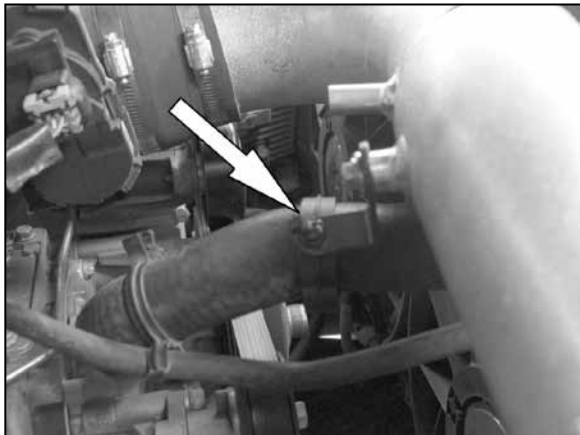

22. Install the upper radiator hose mount onto the "L" bracket installed onto the K&N® intake tube and secure with the provided tie wrap as shown.

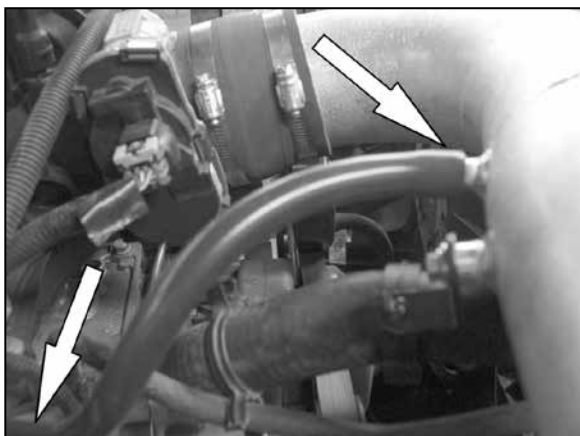

23. Install the provided crank case vent hose onto the valve cover and then onto the K&N® intake tube as shown.



24. Install the K&N® air filter as shown and secure with the provided hose clamp.

NOTE: Drycharger® air filter wrap; part # RF-1042DK is available to purchase separately.



25. Reinstall the engine cover removed in step #3.



26. Reconnect the mass air sensor electrical connection.



27. Reconnect the vehicle's negative battery cable. Double check to make sure everything is tight and properly positioned before starting the vehicle.

28. The C.A.R.B. exemption sticker, (attached), must be visible under the hood so that an emissions inspector can see it when the vehicle is required to be tested for emissions. California requires testing every two years, other states may vary.

29. It will be necessary for all K&N® high flow intake systems to be checked periodically for realignment, clearance and tightening of all connections. Failure to follow the above instructions or proper maintenance may void warranty.

ROAD TESTING:

1. Start the engine with the transmission in neutral or park, and the parking brake engaged. Listen for air leaks or odd noises. For air leaks secure hoses and connections. For odd noises, find cause and repair before proceeding. This kit will function identically to the factory system except for being louder and much more responsive.

2. Test drive the vehicle. Listen for odd noises or rattles and fix as necessary.

3. If road test is fine, you can now enjoy the added power and performance from your kit.

4. K&N Engineering, Inc., requires cleaning the intake system's air filter element every 100,000 miles. When used in dusty or off-road environments, our filters will require cleaning more often. We recommend that you visually inspect your filter once every 25,000 miles to determine if the screen is still visible. When the screen is no longer visible some place on the filter element, it is time to clean it. To clean and re-oil, purchase our filter Recharger® service kit, part number 99-5050 or 99-5000 and follow the easy instructions.