



# INSTALLATION INSTRUCTIONS

## 77-3023KP CHEVROLET / GMC / CADILLAC

Silverado Classic 1500 HD  
 Sierra Classic 1500 HD  
 2007 V8-6.0L  
 Silverado 1500 HD  
 Sierra 1500 HD  
 2005-06 & 2001-03 V8-6.0L  
 Silverado 2500 / Sierra 2500  
 1999-04 V8-6.0L  
 1999-00 V8-5.3L  
 Silverado Classic SS  
 2007 V8-6.0L  
 Silverado SS  
 2003-04 V8-6.0L  
 Tahoe / Yukon  
 2000-2004 V8-4.8L, 5.3L  
 Avalanche 1500  
 2002-04 V8-5.3L  
 Suburban  
 2005-06 V8-6.0L  
 2000-04 V8-6.0L, 5.3L  
 Sierra Classic Denali  
 2007 V8-6.0L  
 Sierra Classic Denali  
 2002-04 V8-6.0L  
 Sierra C3  
 2001 V8-6.0L  
 Yukon XL  
 2005-06 V8-6.0L  
 2000-04 V8-6.0L, 5.3L  
 Yukon Denali / Yukon XL Denali  
 2001-04 V8-6.0L  
 Escalade  
 2002-04 V8-6.0L, 5.3L  
 Escalade EXT  
 2002-04 V8-6.0L  
 Escalade ESV  
 2003-04 V8-6.0L

**TOOLS NEEDED:**  
 Flat blade Screwdriver  
 Ratchet  
 10mm Socket  
 4mm Allen Wrench

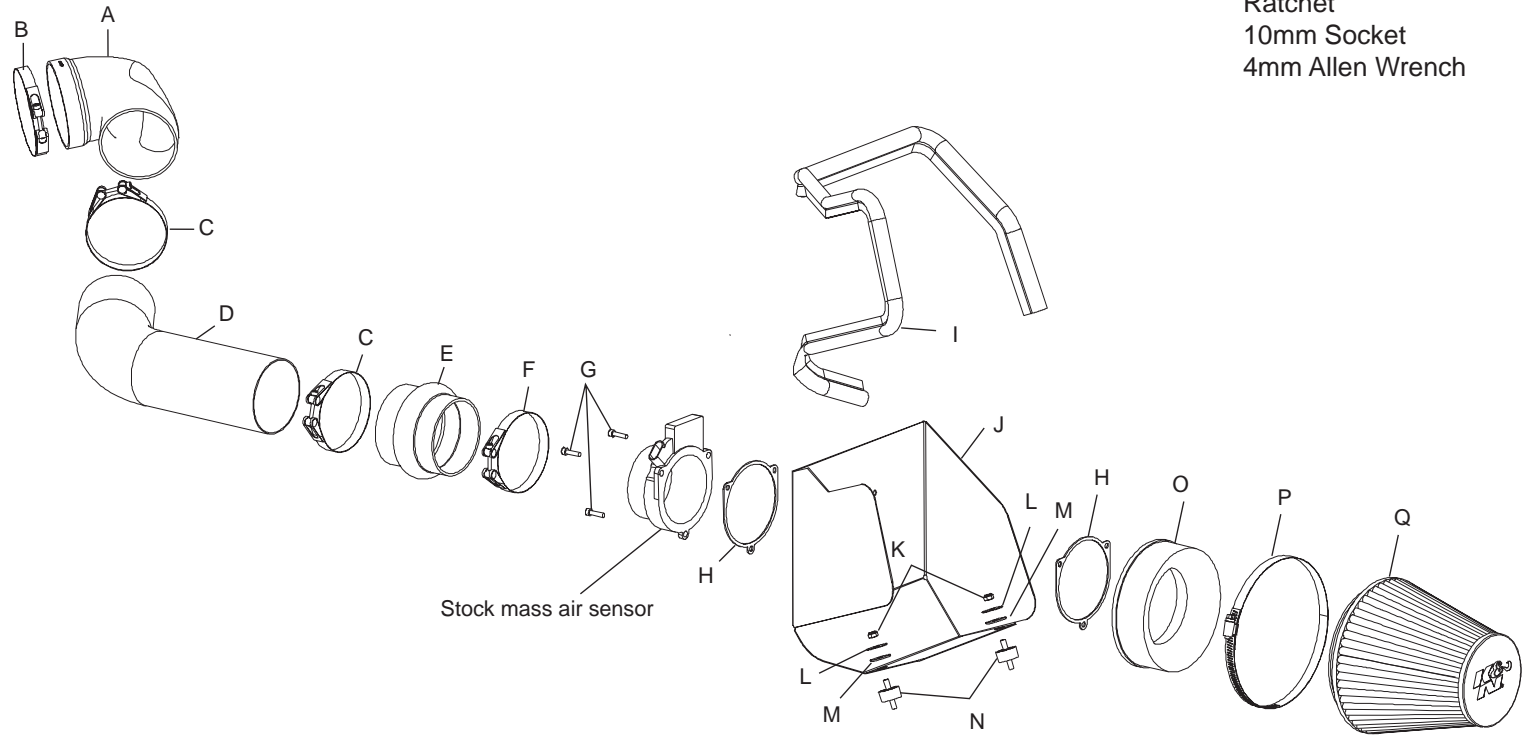

**NOTE:** This kit was not designed to fit vehicles with a body lift.

### PARTS LIST:

Description	Qty.	Part #	Description	Qty.	Part #
A Angled Silicone Hose	1	084053	J Heat Shield	1	07316
B Hose Clamp, #64	1	08645	K Nut, 6mm Nylock	2	07512
C Hose Clamp, #56	2	08620	L Washer, Fender	2	08160
D Performance Intake Tube	1	27141	M Washer, Rubber	2	21685
E Silicone Hump Hose	1	084056	N Rubber Mounted Stud, 6mm	2	07027
F Hose Clamp, 56	1	08620	O Adapter, Mass Air	1	08783
G Bolt, M5-.80, 20mm L. C/H/A	3	08320	P Hose, Clamp, #104	1	08697
H Gasket, 1/16" Neoprene	2	09033	Q Air Filter	1	RC-5046
I Edge Trim, 48" L.	1	102485			

**NOTE: FAILURE TO FOLLOW INSTALLATION INSTRUCTIONS AND NOT USING THE PROVIDED HARDWARE MAY DAMAGE THE INTAKE TUBE, THROTTLE BODY AND ENGINE.**

### TO START:

1. Turn off the ignition and disconnect the negative battery cable.

**NOTE:** Disconnecting the negative battery cable erases pre-programmed electronic memories. Write down all memory settings before disconnecting the negative battery cable. Some radios will require an anti-theft code to be entered after the battery is reconnected. The anti-theft code is typically supplied with your owner's manual. In the event your vehicles' anti-theft code cannot be recovered, contact an authorized dealership to obtain your vehicles anti-theft code.



2. Disconnect the mass air sensor electrical connection as shown.



3. Loosen the hose clamps at the throttle body and at the mass air sensor.



4. Unclip the radiator hose from the intake tube as shown.



5. Disconnect the stock intake tube from the mass air sensor and from the throttle body, then, remove the intake tube as shown.



6. Pull firmly upwards to remove the air cleaner assembly as shown.

**NOTE:** K&N Engineering, Inc., recommends that customers do not discard factory air intake.



7. Loosen the hose clamp on the air cleaner then remove the mass air sensor as shown.



8. Remove the two stock air cleaner support tray bolts as shown.

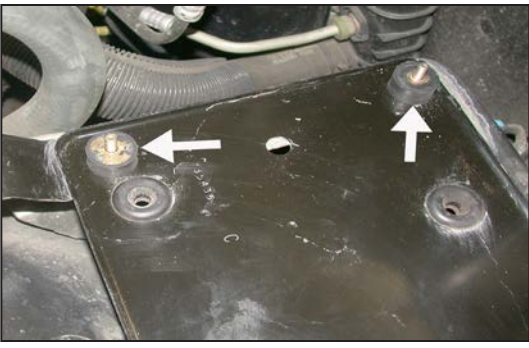

9. Install the rubber mounted studs as shown and tighten firmly.

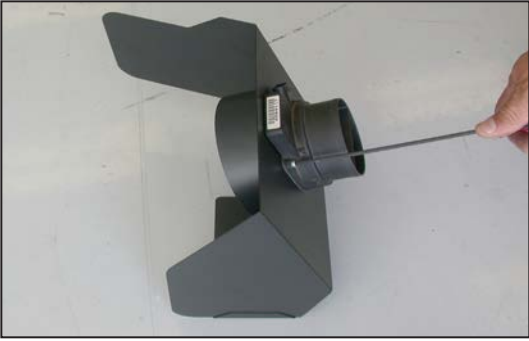

10. Using the provided hardware assemble the mass air adapter, heat shield, gaskets, and the stock mass air sensor as shown.

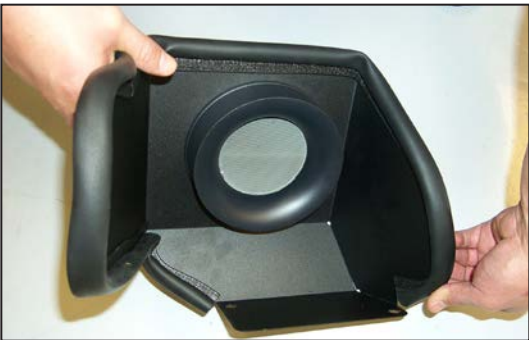

11. Install the edge trim onto the heat shield as shown.



12. Install the heat shield onto the rubber mounted studs as shown.



13. Secure the heat shield to the rubber mounted studs using the provided hardware but do not tighten at this time.



14. Install the silicone angled hose and hose clamps onto the throttle body but do not tighten at this time.



15. Install the silicone step hump hose and hose clamps onto the mass air sensor and tighten as shown.

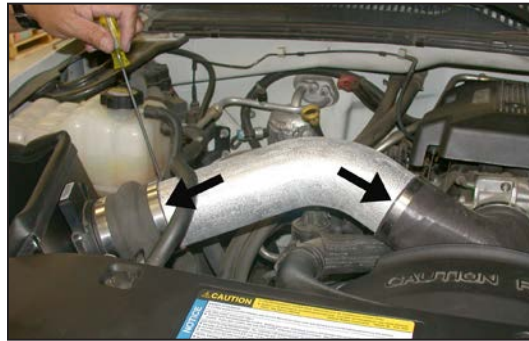

16. Install the K&N® intake tube into the angled hose, then, slide the other end into the hump hose. Adjust everything for best fit and clearance then tighten the hose clamps as shown.



17. Tighten the hardware on the heat shield as shown.



18. Install the K&N® air filter onto the mass air adapter and secure with the provided hose clamp as shown.



19. Reconnect the mass air sensor electrical connection as shown.



20. Reconnect the vehicle's negative battery cable. Double check to make sure everything is tight and properly positioned before starting the vehicle.

21. The C.A.R.B. exemption sticker, (attached), must be visible under the hood so that an emissions inspector can see it when the vehicle is required to be tested for emissions. California requires testing every two years, other states may vary.

22. It will be necessary for all K&N® high flow intake systems to be checked periodically for realignment, clearance and tightening of all connections. Failure to follow the above instructions or proper maintenance may void warranty.

#### ROAD TESTING:

1. Start the engine with the transmission in neutral or park, and the parking brake engaged. Listen for air leaks or odd noises. For air leaks secure hoses and connections. For odd noises, find cause and repair before proceeding. This kit will function identically to the factory system except for being louder and much more responsive.

2. Test drive the vehicle. Listen for odd noises or rattles and fix as necessary.

3. If road test is fine, you can now enjoy the added power and performance from your kit.

4. K&N Engineering, Inc., suggests checking the air filter element periodically for excessive dirt build-up. When the element becomes covered in dirt (or once a year), service it according to the instructions on the Recharger® service kit, part number 99-5050 or 99-5000.