



INSTALLATION INSTRUCTIONS

77-2577KTK

FORD

2008-10 F250 / F350

V8-5.4L

NOTE: This kit was not designed to fit vehicles with a body lift.

TOOLS NEEDED:

Ratchet
Extension
13mm Socket
10mm Socket
Flat Blade Screwdriver
T25 Torx
3mm Allen Wrench

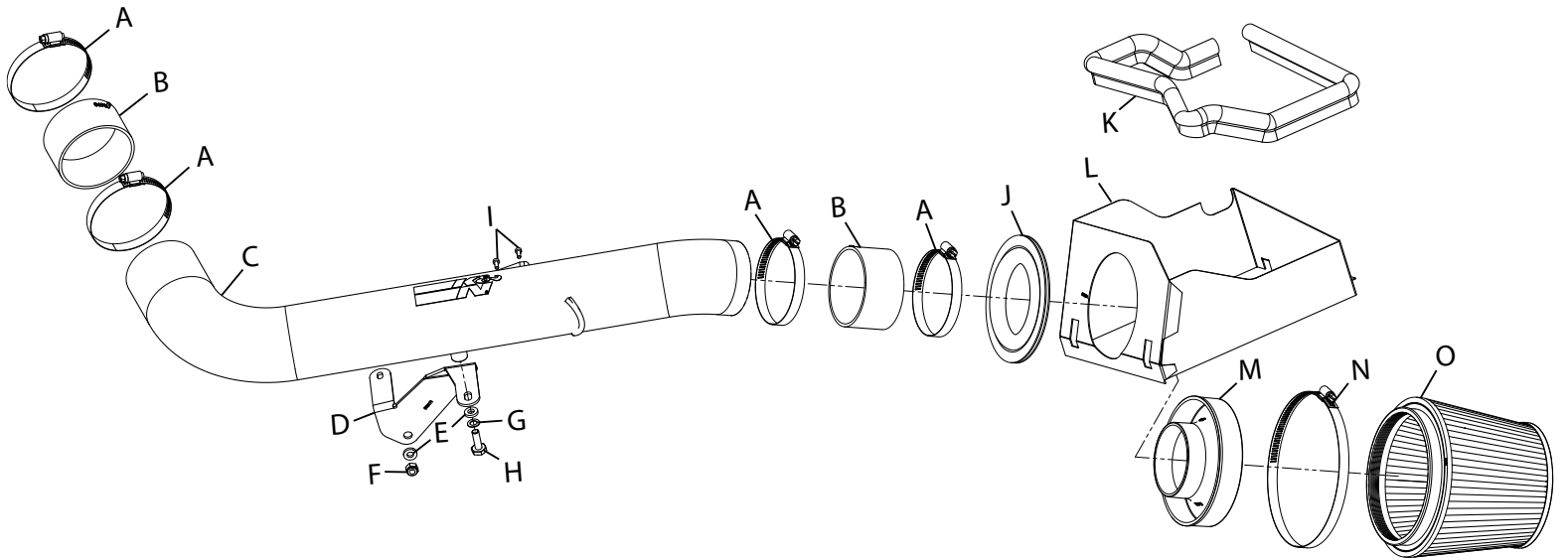

PARTS LIST:

| Description | Qty. | Part # | Description | Qty. | Part # | Description | Qty. | Part # |
|-----------------------------|------|--------|------------------------------------|------|--------|--------------------|------|---------|
| A Hose Clamp #56 | 4 | 08620 | F Nut; 8MM Nylock, SS | 1 | 07502 | K Edge Trim (39") | 1 | 102496 |
| B Hose; 3-1/2" ID X 2" L | 2 | 08698 | G Washer; 8MM Spring(Wave) | 1 | 08239 | L Heat Shield | 1 | 07355-1 |
| C Intake Tube | 1 | 27453 | H Bolt; M8 - 1.0 X 20MM, Tap | 1 | 06533 | M Adaptor; #380 | 1 | 21512-1 |
| D Bracket; "Z", STL, FB/PC | 1 | 083111 | I Bolt; M4 - 0.07 8MM, A/H Cap, SS | 2 | 07733 | N Hose Clamp # 104 | 1 | 08697 |
| E Washer; 5/16"ID X 5/8"OD, | 2 | 08276 | J Edge Trim (17") | 1 | 102469 | O Air Filter | 1 | RC-5173 |

NOTE: FAILURE TO FOLLOW INSTALLATION INSTRUCTIONS AND NOT USING THE PROVIDED HARDWARE MAY DAMAGE THE INTAKE TUBE, THROTTLE BODY AND ENGINE.

TO START:

1. Turn off the ignition and disconnect the negative battery cable.

NOTE: Disconnecting the negative battery cable erases pre-programmed electronic memories. Write down all memory settings before disconnecting the negative battery cable. Some radios will require an anti-theft code to be entered after the battery is reconnected. The anti-theft code is typically supplied with your owner's manual. In the event your vehicles' anti-theft code cannot be recovered, contact an authorized dealership to obtain your vehicles anti-theft code.



2. Release the red locking clip and then disconnect the mass air sensor electrical connection; unhook the wiring harness from the power steering reservoir.



3. Loosen the hose clamps that secure the stock intake tube to the air filter housing and to the intake plenum.



4. Remove the stock intake tube from the vehicle.



5. Release the three clips that secure the air box lid.



6. Remove the air box lid and stock air filter.
NOTE: K&N Engineering, Inc., recommends that customers do not discard factory air intake.



7. Remove the upper alternator mounting bolt shown.
NOTE: This bolt will be reused in the next step.



8. Install the tube mounting bracket (083111) and secure with the provided hardware and the bolt removed in the previous step.

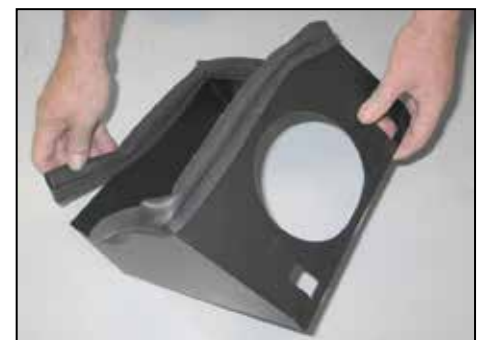

9. Install the provided long edge trim onto the heat shield as shown.
NOTE: Some trimming of the edge trim will be necessary.



10. Install the provided edge trim into the hole in the heat shield as shown.

NOTE: Some trimming of the edge trim will be necessary.



11. Remove the center air box lid mounting clip from the lower air box as shown.



12. Install the heat shield assembly onto the lower air box and clip into place with the upper air box mounting clips.

NOTE: A gap is normal between the lower air box and heat shield on the clip side of the heat shield.



13. Install the provided silicone hose (08698) onto the intake plenum and secure with the provided hose clamp.



14. Install the filter adapter into the K&N® air filter and secure with the provided hose clamp.



15. Install the silicone hose (08698) onto the filter adapter and secure with the provided hose clamp.



16. Place the filter assembly into the lower air box housing as shown.



17. Remove the two screws securing the mass air sensor to the upper air box and then remove the mass air sensor from the upper air box.



18. Install the mass air sensor into the K&N® intake tube and secure with the provided mounting screws.



19. Place the K&N® intake tube through the heat shield, install the air filter assembly onto the end of the tube then install the intake tube into the silicone hose on the intake plenum. Secure the intake tube with the hardware and hose clamps provided.

NOTE: Be sure to secure the air filter assembly with the provided hose clamp.



20. Connect the mass air sensor electrical connection.



21. Reconnect the vehicle's negative battery cable. Double check to make sure everything is tight and properly positioned before starting the vehicle.

22. The C.A.R.B. exemption sticker, (attached), must be visible under the hood so that an emissions inspector can see it when the vehicle is required to be tested for emissions. California requires testing every two years, other states may vary.

23. It will be necessary for all K&N® high flow intake systems to be checked periodically for realignment, clearance and tightening of all connections. Failure to follow the above instructions or proper maintenance may void warranty.

ROAD TESTING:

1. Start the engine with the transmission in neutral or park, and the parking brake engaged. Listen for air leaks or odd noises. For air leaks secure hoses and connections. For odd noises, find cause and repair before proceeding. This kit will function identically to the factory system except for being louder and much more responsive.

2. Test drive the vehicle. Listen for odd noises or rattles and fix as necessary.

3. If road test is fine, you can now enjoy the added power and performance from your kit.

4. K&N Engineering, Inc., requires cleaning the intake system's air filter element every 100,000 miles. When used in dusty or off-road environments, our filters will require cleaning more often. We recommend that you visually inspect your filter once every 25,000 miles to determine if the screen is still visible. When the screen is no longer visible some place on the filter element, it is time to clean it. To clean and re-oil, purchase our filter Recharger® service kit, part number 99-5050 or 99-5000 and follow the easy instructions.