



NOT LEGAL FOR SALE OR USE ON ANY POLLUTION CONTROLLED MOTOR VEHICLE IN CALIFORNIA OR STATES ADOPTING CALIFORNIA EMISSION PROCEDURES.

INSTALLATION INSTRUCTIONS

77-1577KS
JEEP
2019-20 Cherokee
L4-2.4L

TOOLS NEEDED:

- ratchet
- extension
- 8mm socket
- 10mm socket
- flat blade screw driver
- 3/4" wrench
- cutters

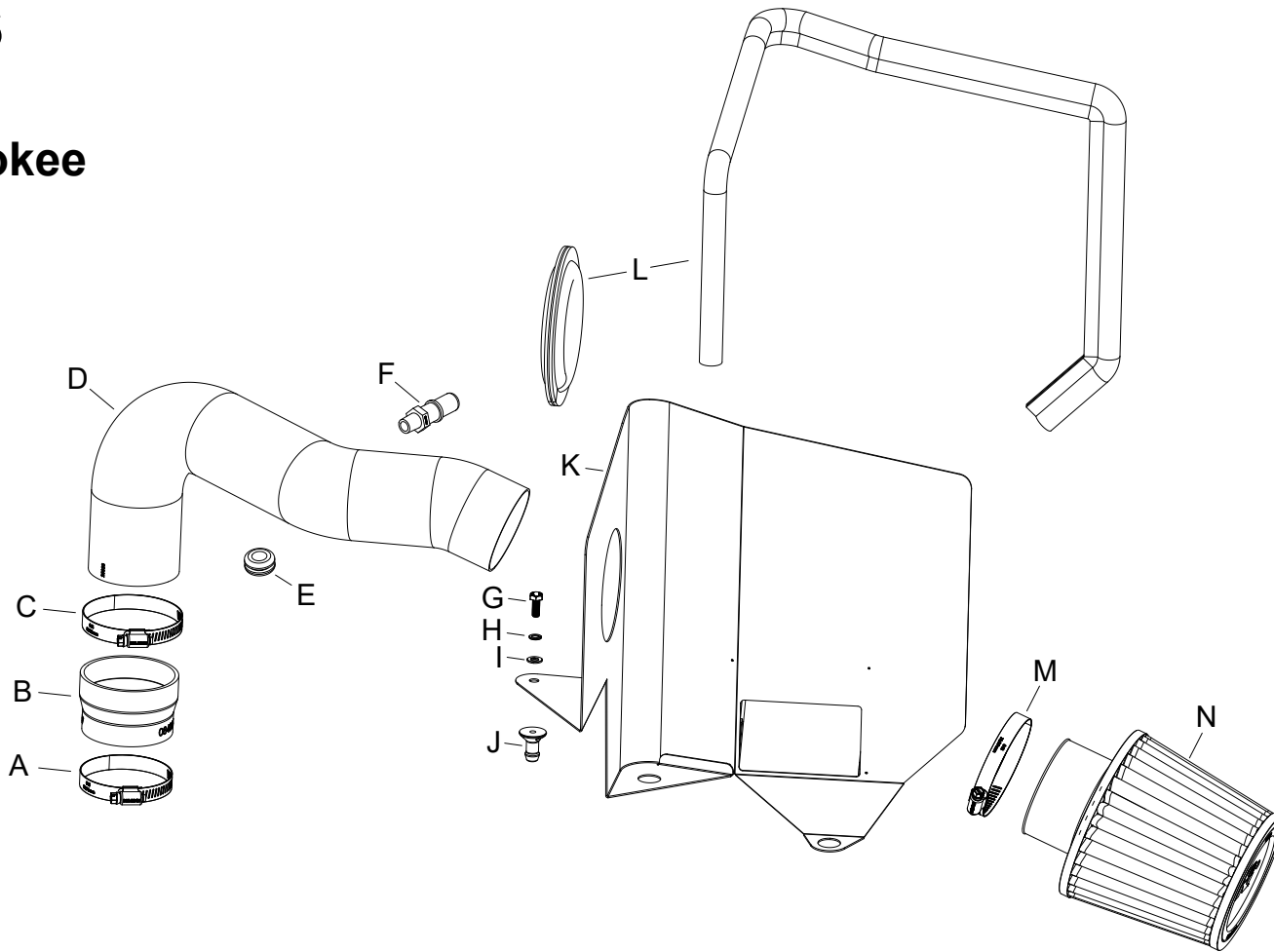

PARTS LIST:

Description	Qty.	Part #	Description	Qty.	Part #	Description	Qty.	Part #
A HOSE CLAMP; #40	1	08554	F VENT; 1/4 NPT QUICK	1	082628	K HEAT SHIELD; MILD	1	07371
B HOSE; 3" TO 2.75"ID X 2"L	1	084036	G BOLT; M6 X 1 X 12MM, SS	1	07727	L EDGE TRIM; 3/4" BULB, TOP	1	102485A
C HOSE CLAMP; #44	1	08577	H WASHER; M6 SPLIT LOCK ZINC	1	1-3025	M HOSE CLAMP; #52	1	08610
D TUBE; 3"OD X 18"L, AL, SILVER	1	25833S	I WASHER; 6MM FLAT, SS	1	08269	N 3"FLG, 6"B, 5"T, 5-9/16"H	1	RU-4990
E GROMMET; 1"OD, 1/2"ID	1	08064	J MOUNT, PLASTIC AIRBOX	1	8-186-1			

NOTE: FAILURE TO FOLLOW INSTALLATION INSTRUCTIONS AND NOT USING THE PROVIDED HARDWARE MAY DAMAGE THE INTAKE TUBE, THROTTLE BODY AND ENGINE.

TO START:

1. Turn off the ignition and disconnect the negative battery cable.
NOTE: Disconnecting the negative battery cable erases pre-programmed electronic memories. Write down all memory settings before disconnecting the negative battery cable. Some radios will require an anti-theft code to be entered after the battery is reconnected. The anti-theft code is typically supplied with your owner's manual. In the event your vehicles anti-theft code cannot be recovered, contact an authorized dealership to obtain your vehicles anti-theft code.



2. Lift up the decorative engine cover to remove it from the engine.



3. Remove the three bolts shown that secure the fresh air intake duct and then remove the duct from the engine.



4. Push in the lock for the PCV vent and then disconnect the PCV vent from the intake tube. Loosen the hose clamp that secures the intake tube to the air filter housing and then disconnect the hose from the housing.



5. Pull the air filter housing straight up and remove it from the vehicle.
NOTE: K&N Engineering, Inc., recommends that customers do not discard factory air intake.



6. Remove the two mounting grommets from the factory air filter housing.



7. Disconnect the IAT sensor electrical connection.



8. Remove the two bolts shown that secure the factory intake tube.



9. Loosen the hose clamp that secures the intake tube to the throttle body and then remove the intake tube from the vehicle.



10. Remove the IAT sensor from the factory intake tube and remove the O-Ring from the sensor.



11. Install the provided grommet and quick disconnect fitting into the K&N intake tube as shown.

NOTE: Plastic NPT fittings are easy to cross thread. Install the vent fitting "hand" tight, then turn it two complete turns with a wrench.



12. Install the IAT sensor into the grommet installed into the K&N intake tube.



13. Cut the edge trim into two sections as shown.



14. Install the edge trim onto the heat shield as shown.



15. Install the mounting stud onto the heat shield as shown.



16. Install the two factory air filter housing mounting brackets onto the heat shield as shown.



17. Install the heat shield into the vehicle as shown so the mounting studs insert into the grommets.



18. Install the provided coupler onto the throttle body and secure with the provided hose clamp.



19. Install the K&N intake tube into the heat shield and then into the coupler, adjust the tube for best fit and then secure with the provided hose clamp.



20. Reconnect the IAT sensor electrical connection.

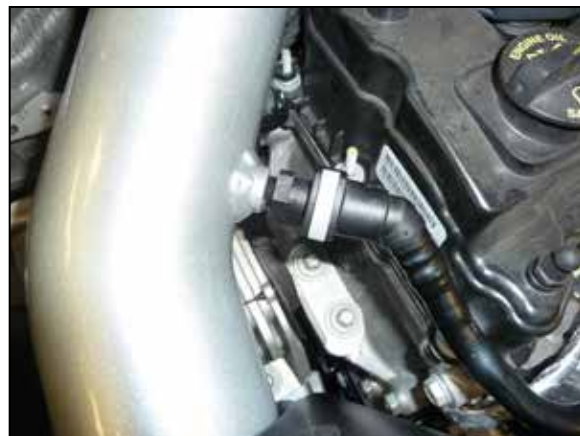

21. Reconnect the PCV to the Quick connect fitting installed into the K&N intake tube.



22. Install the K&N® air filter onto the intake tube and secure with the provided hose clamp.
NOTE: Drycharger® air filter wrap; part # RX-4990DK is available to purchase separately.



23. Reinstall the fresh air intake duct and secure with the factory hardware.



24. Reinstall the decorative engine cover.



25. Reconnect the vehicle's negative battery cable. Double check to make sure everything is tight and properly positioned before starting the vehicle.

26. It will be necessary for all K&N® high flow intake systems to be checked periodically for realignment, clearance and tightening of all connections. Failure to follow the above instructions or proper maintenance may void warranty.

ROAD TESTING:

1. Start the engine with the transmission in neutral or park, and the parking brake engaged. Listen for air leaks or odd noises. For air leaks secure hoses and connections. For odd noises, find cause and repair before proceeding. This kit will function identically to the factory system except for being louder and much more responsive.
2. Test drive the vehicle. Listen for odd noises or rattles and fix as necessary.
3. If road test is fine, you can now enjoy the added power and performance from your kit.
4. K&N Engineering, Inc., requires cleaning the intake system's air filter element every 100,000 miles. When used in dusty or off-road environments, our filters will require cleaning more often. We recommend that you visually inspect your filter once every 25,000 miles to determine if the screen is still visible. When the screen is no longer visible some place on the filter element, it is time to clean it. To clean and re-oil, purchase our filter Recharger® service kit, part number 99-5050 or 99-5000 and follow the easy instructions.

NOT LEGAL FOR SALE OR USE ON ANY POLLUTION CONTROLLED MOTOR VEHICLE IN CALIFORNIA OR STATES ADOPTING CALIFORNIA EMISSION PROCEDURES.