



INSTALLATION INSTRUCTIONS

77-1565KS JEEP 2015-17 Renegade L4-2.4L

TOOLS NEEDED:

flat blade screw driver
4mm allen key
ratchet
extension
10mm socket
3mm allen key
pliers

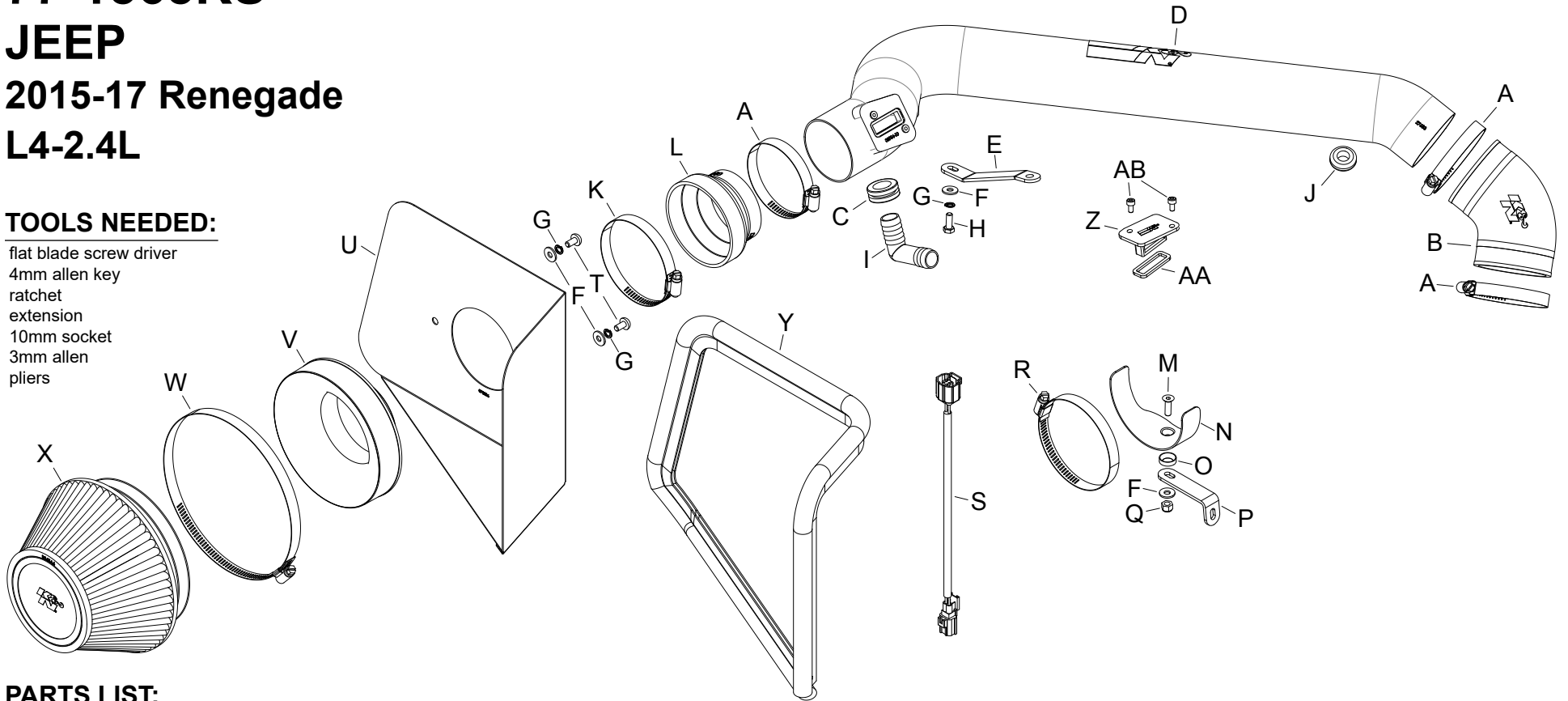

PARTS LIST:

Description	Qty.	Part #	Description	Qty.	Part #	Description	Qty.	Part #
A HOSE CLAMP #44 STAINLESS	3	08560	J GROMMET; 1-1/16OD, 1/2ID, 3/8	1	080544	S EXTENSION HARNESS	1	21680
B HOSE; 2.75"ID ANGLED 30DEG	1	08489	K HOSE CLAMP #52	1	08610	T BOLT; M6 X 1.00" 12MM, SS	2	07794
C GROMMET; 3/4"ID	1	08058	L HOSE; 3-1/2" TO 2-3/4" ID X 2" L	1	084093	U HEAT SHIELD	1	073206
D TUBE; 2.75"OD X 31"L, AL, SILV	1	27633S	M BOLT 6MM X 1.00 X 20 FHA	1	08376	V ADAPTER; UNIVERSAL, 6", 3.5"	1	21512-1
E BRACKET; "Z", 77-1565, STL	1	064335	N BRACKET; 59-4540, SADDLE	1	078855	W HOSE CLAMP # 104	1	08697
F WASHER; 6MM FLAT, SS	4	08269	O WASHER; CONICAL, NYLON	1	08180	X AIR FILTER	1	RU-4600
G WASHER, M6 SPLIT LOCK ZINC	3	1-3025	P BRACKET; "L", 69-3515, STL	1	070109	Y EDGE TRIM (46")	1	102487
H BOLT; 6MM-1.00 X 16MM, SS	1	07812	Q NUT; 6MM NYLOCK, HEXHEAD	1	07512	Z BLOCK OFF PLATE; MASS AIR	1	21508
I VENT; 90DEG, 3/4" HOSE	1	A2128-44	R HOSE CLAMP #56	1	08620	AA GASKET; MASS AIR	1	09076
						AB BOLT; M4-0.07 8MM A/H CAP	2	07733

NOTE: FAILURE TO FOLLOW INSTALLATION INSTRUCTIONS AND NOT USING THE PROVIDED HARDWARE MAY DAMAGE THE INTAKE TUBE, THROTTLE BODY AND ENGINE.

TO START:

1. Turn off the ignition and disconnect the negative battery cable.

NOTE: Disconnecting the negative battery cable erases pre-programmed electronic memories. Write down all memory settings before disconnecting the negative battery cable. Some radios will require an anti-theft code to be entered after the battery is reconnected. The anti-theft code is typically supplied with your owner's manual. In the event your vehicles anti-theft code cannot be recovered, contact an authorized dealership to obtain your vehicles anti-theft code.



2. Remove the bolt securing the engine cover and then remove the engine cover from the vehicle.
NOTE: This bolt will be reused in a later step.



3. Disconnect the inlet air temperature sensor electrical connection, unhook the heater hose from the clip securing it to the intake tube and then loosen the hose clamp that secures the intake tube to the throttle body.



4. Remove the bolt that secures the intake tube to the valve cover.



5. On vehicles equipped with a mass air sensor, Disconnect the wiring harness from the sensor.



6. Disconnect the crank case vent hose from the fitting in the intake tube.



7. Dislodge the air filter housing from the mounting grommets and then remove the complete intake system from the vehicle.

NOTE: K&N Engineering, Inc., recommends that customers do not discard factory air intake.



8. Install the provided coupling hose (08489) onto the throttle body with the hose clamps but do not tighten at this time.



9. On vehicles equipped with a mass air sensor, remove the two screws securing the sensor into the factory air filter housing and then remove the sensor as shown.



10. On vehicles equipped with a mass air sensor, install the sensor into the K&N® intake tube and secure with the provided hardware. On vehicles that are not equipped with a humidity sensor, install the provided gasket onto the block off and then install the block off into the K&N® intake tube and secure with the provided hardware.



11. Install the tube mounting bracket (064335) onto the K&N® intake tube as shown using the provided hardware.

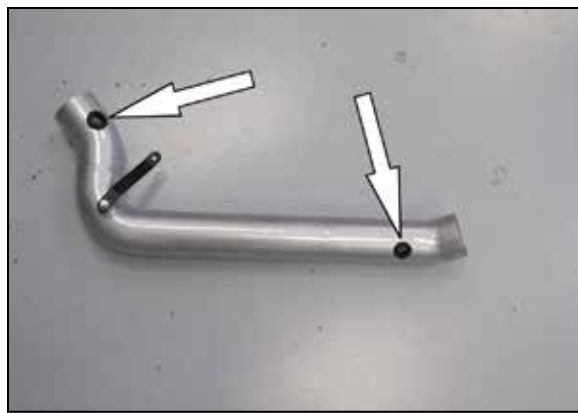

12. Install the two provided grommets into the K&N® intake tube as shown.



13. Install the 90° vent fitting into the grommet installed into the K&N® intake tube as shown.



14. Remove the inlet air temperature sensor from the factory air filter housing.

NOTE: The inlet air temperature sensor is very fragile, use care while handling the sensor so as not to damage it.



15. Remove the O-Ring from the sensor and then install the sensor into the grommet installed into the K&N® intake tube.



16. Connect the inlet air temperature extension harness provided to the sensor as shown.



17. Install the K&N® intake tube assembly into the coupling hose and align the bracket with the mounting lug on the valve cover. Tighten the hose clamps but do not secure the bracket to the valve cover.



18. Connect the inlet air temperature extension harness to the factory harness.



19. Install the engine cover and align the tube mounting bracket then secure the bracket and engine cover using the factory bolt from step #2.



20. Connect the crank case vent hose to the fitting installed into the K&N® intake tube.

NOTE: Connect mass air sensor if equipped.



21. Remove the inner fender bolt shown.
NOTE: This bolt will be reused.



22. Assemble the saddle onto the provided bracket (070109) as shown using the provided hardware.



23. Install the saddle assembly onto the inner fender using the factory bolt removed in step #18 and then secure the fresh air intake duct with the provided hose clamp.



24. Install the filter adapter into the heat shield as shown using the provided hardware.



25. Install the provided edge trim onto the heat shield as shown.

NOTE: Some trimming of the edge trim will be necessary.



26. Install the provided coupling hose (084093) onto the filter adapter and secure with the provided hose clamp.



27. Install the K&N® air filter onto the filter adapter and secure with the provided hose clamp.



28. Install the filter assembly onto the K&N® intake tube and adjust for best fit and then secure with the provided hose clamp.



29. Reconnect the vehicle's negative battery cable. Double check to make sure everything is tight and properly positioned before starting the vehicle.

30. It will be necessary for all K&N® high flow intake systems to be checked periodically for realignment, clearance and tightening of all connections. Failure to follow the above instructions or proper maintenance may void warranty.

ROAD TESTING:

1. Start the engine with the transmission in neutral or park, and the parking brake engaged. Listen for air leaks or odd noises. For air leaks secure hoses and connections. For odd noises, find cause and repair before proceeding. This kit will function identically to the factory system except for being louder and much more responsive.

2. Test drive the vehicle. Listen for odd noises or rattles and fix as necessary.

3. If road test is fine, you can now enjoy the added power and performance from your kit.

4. K&N Engineering, Inc., requires cleaning the intake system's air filter element every 100,000 miles. When used in dusty or off-road environments, our filters will require cleaning more often. We recommend that you visually inspect your filter once every 25,000 miles to determine if the screen is still visible. When the screen is no longer visible some place on the filter element, it is time to clean it. To clean and re-oil, purchase our filter Recharger® service kit, part number 99-5050 or 99-5000 and follow the easy instructions.