



TYPHOON INTAKE SYSTEMS

INSTALLATION INSTRUCTIONS

69-8003TFK SUBARU 2005-09 Legacy GT H4-2.5L Turbo

TOOLS NEEDED:

Flat Blade Screwdriver
Phillips Screwdriver
3mm Allen Wrench
10mm End Wrench
Ratchet
Extension
10mm Socket

PARTS LIST:

Description	Qty.	Part #
A Air Filter	1	RP-5113
B Hose Clamp #80	1	08694
C Adaptor #350	1	21510
D Stud; 6mm - 1.00 X 35mm, SS	4	08220
E Gasket; Neoprene	2	09202
F Heat Shield	1	07336
G Trim Seal - 30"L	1	102489
H Tie Wrap, 12"L	1	21590
I Stud, 6mm Rubber	2	07027
J Washer; 6mm, SS	6	08269
K Nut, 6mm Nylock	6	07512
L Heat Shield, Small	1	03467
M M4 Bolt, SS	2	07733
N Intake Tube	1	27502TK
O Hose Clamp #44, SS	2	08560
P Hose, Silicone; 2-3/4 X 2"L	1	08440

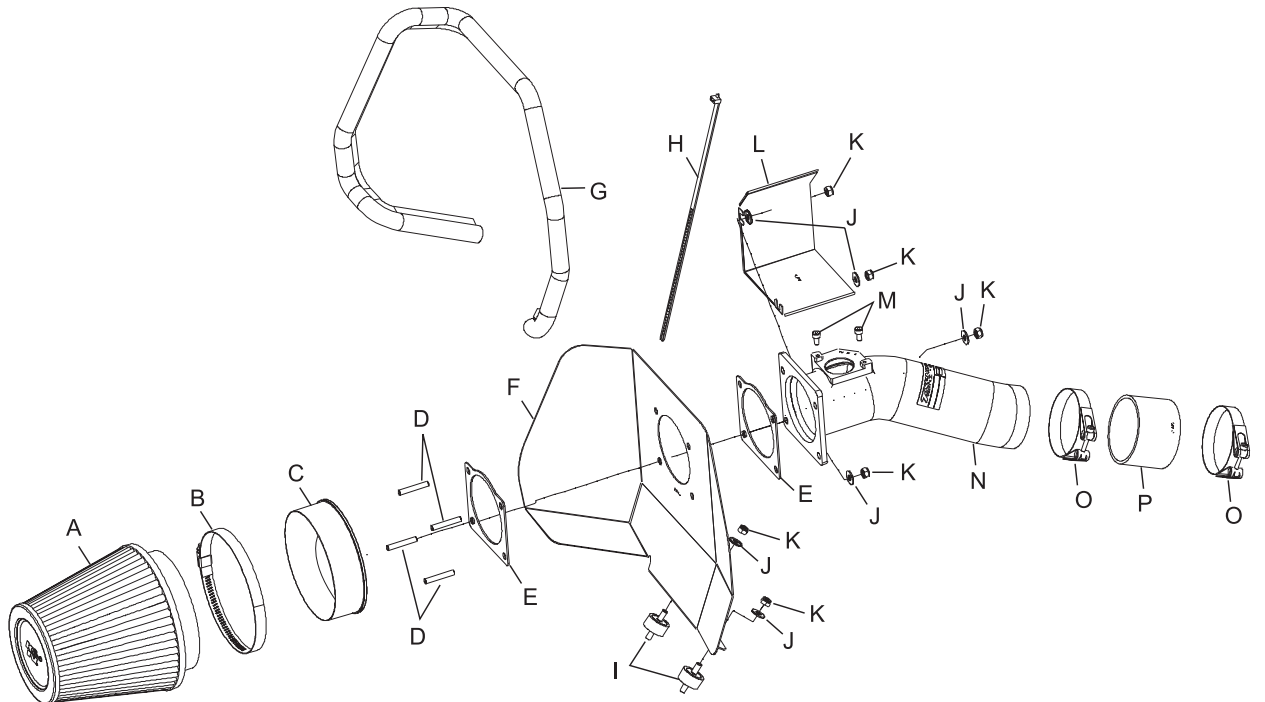

NOTE: FAILURE TO FOLLOW INSTALLATION INSTRUCTIONS AND NOT USING THE PROVIDED HARDWARE MAY DAMAGE THE INTAKE TUBE, THROTTLE BODY AND ENGINE.

TO START:

1. Turn off the ignition and disconnect the negative battery cable.

NOTE: Disconnecting the negative battery cable erases pre-programmed electronic memories. Write down all memory settings before disconnecting the negative battery cable. Some radios will require an anti-theft code to be entered after the battery is reconnected. The anti-theft code is typically supplied with your owner's manual. In the event your vehicles' anti-theft code cannot be recovered, contact an authorized dealership to obtain your vehicles anti-theft code.



2. Remove the engine cover, which is secured by four plastic rivets.



3. Remove the air inlet scoop, which is secured to the radiator core support by two plastic rivets.



4. Disconnect the mass air sensor electrical connection and unclip the harness from the side of the air cleaner as shown.

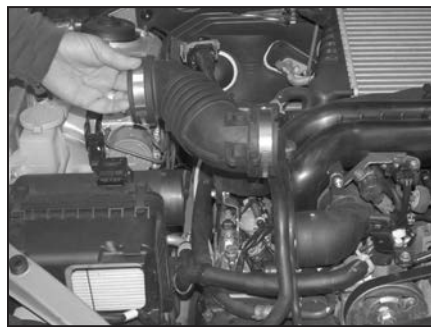

5. Loosen the hose clamps at the air cleaner and at the turbo inlet tube, then, unclip the coolants hoses from the stock intake hose and remove the stock intake hose as shown.



6. Loosen and remove the two hex bolts that secure the air cleaner to the inner fender as shown.



7. Remove the hex nut that secure that air cleaner to the bracket on the inner fender as shown.



8a. Pull the air cleaner upwards and unclip the coolant hose and the mass air sensor wire harness from the side of the air cleaner.



8b. Then remove the air cleaner as shown. **NOTE: K&N Engineering, Inc., recommends that customers do not discard factory air intake.**



9. Remove the mass air sensor from the air cleaner assembly as shown.



10. Install the mass air sensor into the K&N® intake tube and secure with the provided hardware as shown.



11. Install the trim seal onto the heat shield and trim to fit if necessary.

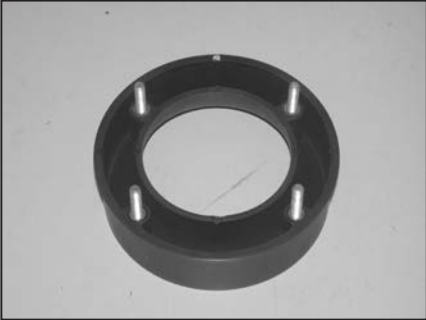

12. Install the provided studs into the provided radiused adapter as shown.



13. Apply one of the provided gaskets onto the adapter as shown.



14. Install the adapter onto the heat shield and apply the remaining gasket onto the heat shield as shown.



15. Install the intake tube onto the studs and secure with two of the provided nylock nuts and flat washers as shown in the orientation.



16. Install the heat deflector plate onto the tube flange and secure it with two nylock nuts and flat washers as shown.

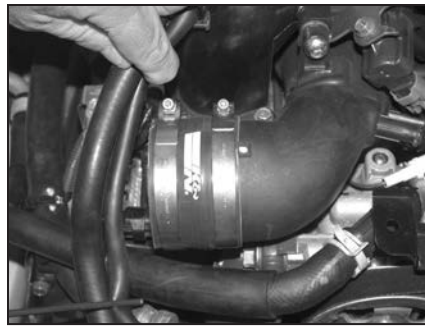

17. Install the provided silicone hose and hose clamps onto the turbo inlet tube as shown.



18. Install the provided rubber mounted studs into the original air cleaner mounting holes as shown.

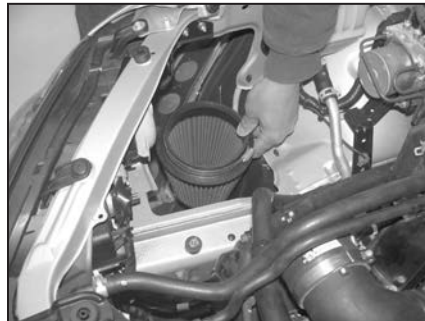

19. Place the K&N® air filter into the cavity in the inner fender as shown.



20. Install the complete assembly into the vehicle as shown.



21. Line up the heat shield with the rubber mounted studs and secure with the provided nylock nuts, then, slide the intake tube into the silicone hose and secure as shown.



22. Slide the K&N® air filter onto the radiused adapter and secure with the provided hose clamp as shown.



23. Reconnect the mass air sensor electrical connection as shown.



24. Zip-tie the coolant hose and power steering hose together as shown.



25. Reconnect the vehicle's negative battery cable. Double check to make sure everything is tight and properly positioned before starting the vehicle.

26. The C.A.R.B. exemption sticker, (attached), must be visible under the hood so that an emissions inspector can see it when the vehicle is required to be tested for emissions. California requires testing every two years, other states may vary.

27. It will be necessary for all K&N® high flow intake systems to be checked periodically for realignment, clearance and tightening of all connections. Failure to follow the above instructions or proper maintenance may void warranty.

ROAD TESTING:

1. Start the engine with the transmission in neutral or park, and the parking brake engaged. Listen for air leaks or odd noises. For air leaks secure hoses and connections. For odd noises, find cause and repair before proceeding. This kit will function identically to the factory system except for being louder and much more responsive.

2. Test drive the vehicle. Listen for odd noises or rattles and fix as necessary.

3. If road test is fine, you can now enjoy the added power and performance from your kit.

4. K&N Engineering, Inc., requires cleaning the intake system's air filter element every 100,000 miles. When used in dusty or off-road environments, our filters will require cleaning more often. We recommend that you visually inspect your filter once every 25,000 miles to determine if the screen is still visible. When the screen is no longer visible some place on the filter element, it is time to clean it. To clean and re-oil, purchase our filter Recharger® service kit, part number 99-5050 or 99-5000 and follow the easy instructions.