

# K&N TYPHOON INTAKE SYSTEMS

## INSTALLATION INSTRUCTIONS

69-7077TTK

NISSAN

2009-10 Cube

L4-1.8L

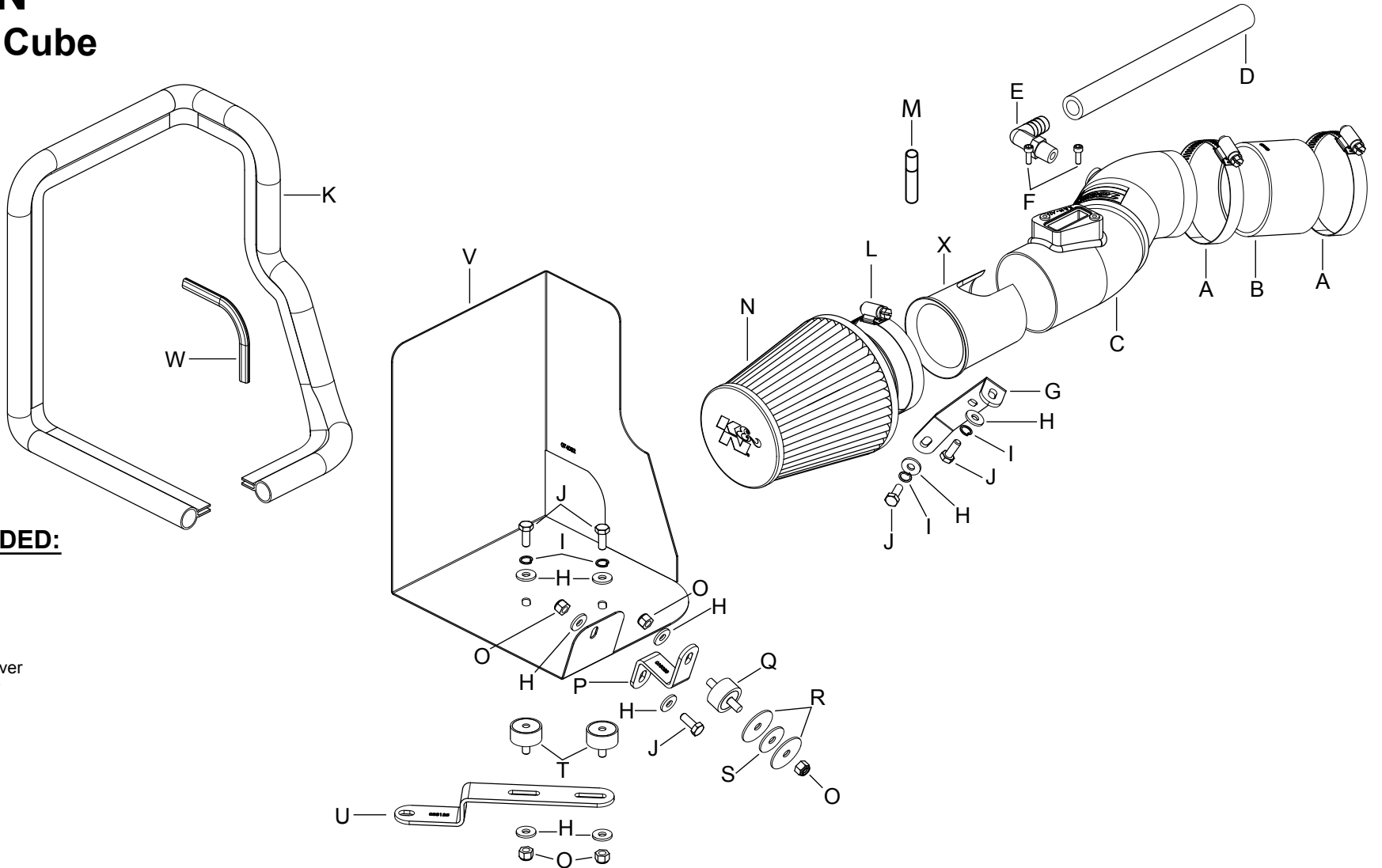

### TOOLS NEEDED:

Ratchet  
Extension  
12mm Socket  
10mm Socket  
Pliers  
Flat Blade Screwdriver  
Phillips Screwdriver  
10mm Wrench  
3mm Allen Wrench

### PARTS LIST:

Description	Qty.	Part #	Description	Qty.	Part #	Description	Qty.	Part #
A Hose Clamp #44 Stainless	2	08560	I Washer; 1/4" Lock, ZN	4	08198	Q Stud; M6-1.00 M/M, Rubber Mntd.	1	07027
B Hose; 2-3/4" ID X 2" L Reinforced	1	08440	J Bolt; 6mm-1.00 X 16mm, SS	5	07812	R Washer; 1.25D X .28 Hol	2	08151
C Intake Tube	1	27445	K Edge Trim (44")	1	102486	S Washer; 1" X .300 X .100 Rubber	1	21685
D Hose; 1/2" ID X 9" L	1	08401	L Hose Clamp #44	1	08577	T Stud; M/F, 1/2"L X 1"w, M6 X 1.00	2	070228
E Vent; 90Deg, 1/2"Hose, 1/4"NPT	1	08110FK	M Super Glue	1	409	U Bracket; "Z", 69-7077, Stl, TK/PC	1	083125
F Bolt; M4 - 0.07 8mm, A/h Cap, SS	2	07733	N Air Filter	1	RC-9350	V Heat Shield	1	074052
G Bracket; "C", STL, TK/PC	1	083124	O Nut; 6mm Nylock, Hexhead, SS	5	07512	W Edge Trim (7")	1	102452
H Washer; 1/4"IDx5/8"OD - SAE	9	08275	P Bracket; "Z", Stl, TK/PC	1	010033	X Venturi, Maf Insert, 2.75"	1	9-479

**NOTE: FAILURE TO FOLLOW INSTALLATION INSTRUCTIONS AND NOT USING THE PROVIDED HARDWARE MAY DAMAGE THE INTAKE TUBE, THROTTLE BODY AND ENGINE.**

### TO START:

1. Turn off the ignition and disconnect the negative battery cable.

**NOTE: Disconnecting the negative battery cable erases pre-programmed electronic memories. Write down all memory settings before disconnecting the negative battery cable. Some radios will require an anti-theft code to be entered after the battery is reconnected. The anti-theft code is typically supplied with your owner's manual. In the event your vehicles' anti-theft code cannot be recovered, contact an authorized dealership to obtain your vehicles anti-theft code.**



2. Disconnect the mass air sensor electrical connection.



3. Remove the two bolts which secure the engine cover then remove the engine cover as shown.



4. Lift the intake resonator up to unhook it from the three mounting grommets and then remove the resonator from the vehicle.

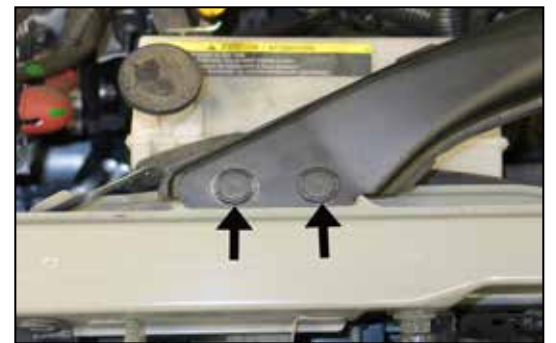

5. Release the center locking pins and then remove the two mounting pins securing the fresh air inlet tube.



6. Remove the upper fresh air inlet duct from the vehicle.



7. Remove the positive battery cable and battery mounting bracket, then remove the battery from the vehicle.



8. Loosen the two hose clamps securing the intake tube and the spring clamp securing the crank case vent hose to the valve cover.



9. Remove the intake hose assembly.



10. Disconnect the transmission vent line and wiring harness from the air box.  
**NOTE: The transmission vent line is held on in two locations.**



11. Lift up the air box to dislodge it from the mounting grommets and then remove the air box from the vehicle.  
**NOTE: K&N Engineering, Inc., recommends that customers do not discard factory air intake.**



12. Remove the three air box mounting grommets shown from the air box mounts.



13. Unhook the wiring harness shown from the water neck housing location shown.



14. Unhook the evap/fuel lines from the mounting bracket, install the provided tube mounting bracket (083124) onto the water neck boss and secure with the provided hardware. Secure the evap/fuel lines to the hole provided in the tube mounting bracket.  
**NOTE: The tube mounting bracket will attach to the water neck housing location referenced in step #13.**



15. Install one of the provided rubber mounted studs onto the rear air box mounting bracket as shown.  
**NOTE: Be sure to use two fender washers and one rubber washer provided while securing the rubber mounted stud to the bracket.**



16. Install the provided bracket (010033) onto the rubber mounted stud installed in step #16 and secure with the provided hardware.



17. Install the two provided rubber mounted studs onto the heat shield mounting bracket (083125) as shown. Do not completely tighten at this time.



18. Remove the air box mounting plate bolt shown.  
**NOTE: This bolt will be reused in the next step.**



19. Install the heat shield mounting bracket assembly onto the air box mounting plate as shown and secure with the bolt from the previous step.



20. Install the provided edge trim onto the heat shield as shown.

**NOTE: Some trimming of the edge trim will be necessary.**



21. Install the provided edge trim into the heat shield fresh air duct opening as shown.

**NOTE: Some trimming of the edge trim will be necessary.**



22. Set the heat shield into position on the mounting bracket and rubber mounted studs then adjust as necessary. Secure the heat shield and bracket with the provided hardware.



23. Install the provided silicone hose (08440) onto the throttle body and secure with the provided hose clamp.



24. Remove the screws securing the mass air sensor and then remove the mass air sensor from the stock air box.



25. Install the mass air sensor into the K&N® intake tube and secure with the provided hardware.



26. Install the mass air sensor venturi into the K&N® intake tube as shown.

**NOTE: Apply a thin coat of the provided super glue on the lip of the venturi.**



27. Install the provided 90° vent fitting onto the K&N® intake tube as shown.

**NOTE: Plastic NPT fittings are easy to cross thread. Install the vent fitting "hand" tight, then turn it two complete turns with a wrench.**



28. Install the K&N® intake tube into the silicone hose at the throttle body and align with the tube mounting bracket. Secure the intake tube with the hose clamp and hardware provided.



29. Install the provided silicone hose onto the crank case vent port on the valve cover and then attach the other end to the 90° fitting installed in the K&N® intake tube.



30. Install the K&N® air filter onto the intake tube and secure with the provided hose clamp.

**NOTE: Drycharger® air filter wrap; part # RC-9350DK is available to purchase separately.**



31. Reconnect the mass air sensor electrical connection.



32. Remove the lower fresh air duct from the air box as shown.



33. Install the lower fresh air duct into the heat shield as shown.



34. Install the upper fresh air duct into the lower section and then secure with the factory retaining clips to the radiator core support.



35. Reinstall the battery and secure with the factory hold down. Reconnect the positive and then the negative battery cables.



36. Reinstall the intake resonator onto the fresh air intake duct.



37. Reinstall the engine cover and secure with the factory mounting bolts.



38. Double check to make sure everything is tight and properly positioned before starting the vehicle.

39. The C.A.R.B. exemption sticker, (attached), must be visible under the hood so that an emissions inspector can see it when the vehicle is required to be tested for emissions. California requires testing every two years, other states may vary.

40. It will be necessary for all K&N® high flow intake systems to be checked periodically for realignment, clearance and tightening of all connections. Failure to follow the above instructions or proper maintenance may void warranty.

#### ROAD TESTING:

1. Start the engine with the transmission in neutral or park, and the parking brake engaged. Listen for air leaks or odd noises. For air leaks secure hoses and connections. For odd noises, find cause and repair before proceeding. This kit will function identically to the factory system except for being louder and much more responsive.

2. Test drive the vehicle. Listen for odd noises or rattles and fix as necessary.

3. If road test is fine, you can now enjoy the added power and performance from your kit.

4. K&N Engineering, Inc., requires cleaning the intake system's air filter element every 100,000 miles. When used in dusty or off-road environments, our filters will require cleaning more often. We recommend that you visually inspect your filter once every 25,000 miles to determine if the screen is still visible. When the screen is no longer visible some place on the filter element, it is time to clean it. To clean and re-oil, purchase our filter Recharger® service kit, part number 99-5050 or 99-5000 and follow the easy instructions.