



TYPHOON INTAKE SYSTEMS

INSTALLATION INSTRUCTIONS

69-7064TS NISSAN 2013-14 Altima L4-2.5L

NOTE: EXCLUDING LEV2 SULEV
2013-14 TEST GROUPS DNSXR02.585A,
ENSXR02.585A

TOOLS NEEDED:

ratchet
extension
10mm socket
10mm wrench
phillips screw driver
flat head screw driver
5mm allen key
3mm allen key
pliers

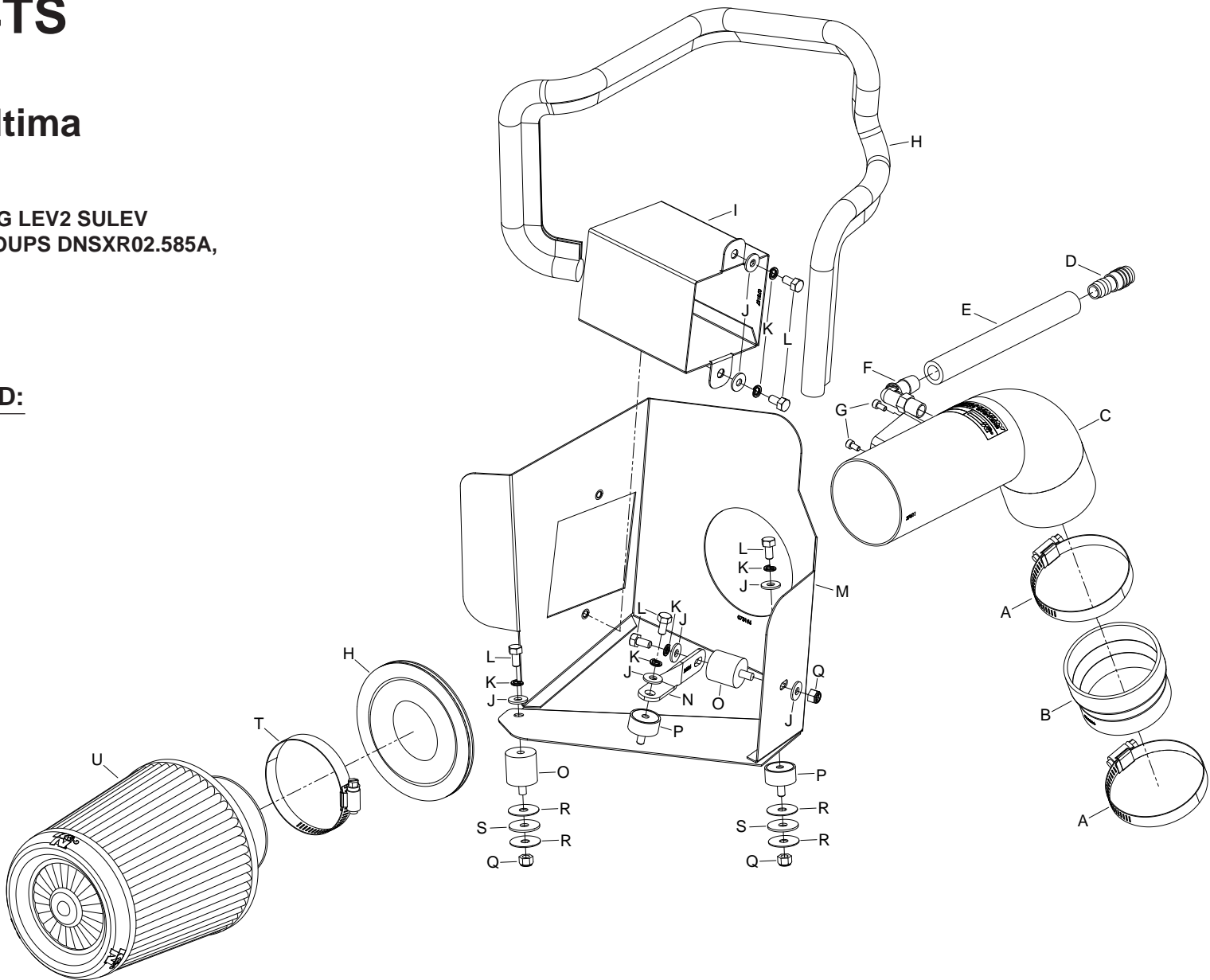

PARTS LIST:

Description	Qty.	Part #	Description	Qty.	Part #	Description	Qty.	Part #
A Hose Clamp #44 Stainless	2	08560	H Edge Trim (55")	1	102480	O Stud; Rubber; mount, M6 X 1, 1"	2	02033
B Hose; 3" To 2-3/4" ID X 2"L TPRD	1	084036	I Scoop	1	073157	P Stud; Rubber MNT, M/F, 1/2"L	2	070228
C Intake Tube	1	27611TS	J Washer; 6MM, Flat, SS	7	08269	Q Nut; 6MM Nylock, Hexhead, SS	3	07512
D Hose Mender; 1/2" To 5/8"	1	08726	K Washer, M6 Split Lock Zinc	6	1-3025	R Washer; 1"D X 1/4 Hole Fender	4	08160
E Hose; 1/2"ID X 7"L	1	08159	L Bolt; M6 X 1.00 X 12MM, SS	6	07727	S Washer; 1" X .300 X .100 Rubber	2	21685
F Vent; 90DEG, 1/2"Hose, 1/4"NPT	1	08110FK	M Heat Shield	1	073156	T Hose Clamp #48	1	08601
G Bolt; M4-0.07 8MM, A/H Cap, SS	2	07733	N Bracket; 57-9016, TB/PC	1	26606	U Air Filter	1	RX-4730XD

NOTE: FAILURE TO FOLLOW INSTALLATION INSTRUCTIONS AND NOT USING THE PROVIDED HARDWARE MAY DAMAGE THE INTAKE TUBE, THROTTLE BODY AND ENGINE.

TO START:

1. Turn off the ignition and disconnect the negative battery cable.
NOTE: Disconnecting the negative battery cable erases pre-programmed electronic memories. Write down all memory settings before disconnecting the negative battery cable. Some radios will require an anti-theft code to be entered after the battery is reconnected. The anti-theft code is typically supplied with your owner's manual. In the event your vehicles anti-theft code cannot be recovered, contact an authorized dealership to obtain your vehicles anti-theft code.



2. Disconnect the mass air sensor electrical connection and unhook the wiring harness from the air box.

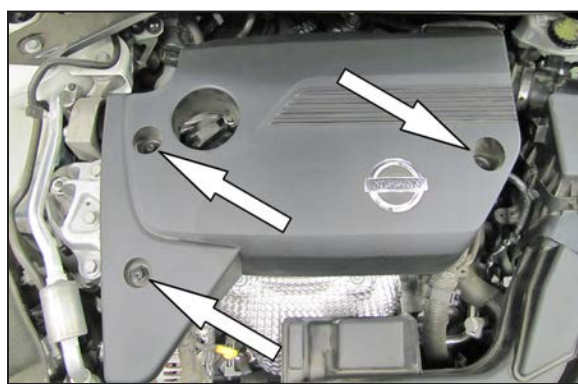

3. Remove the three bolts securing the engine cover and then lift off the engine cover.

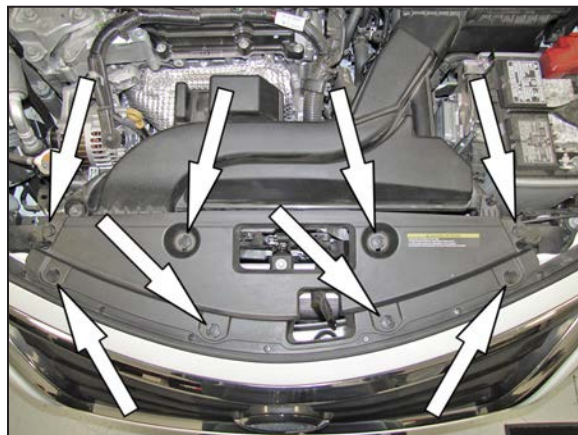

4. Pop up the eight plastic clips securing the core support cover and then remove the core support cover from the engine.

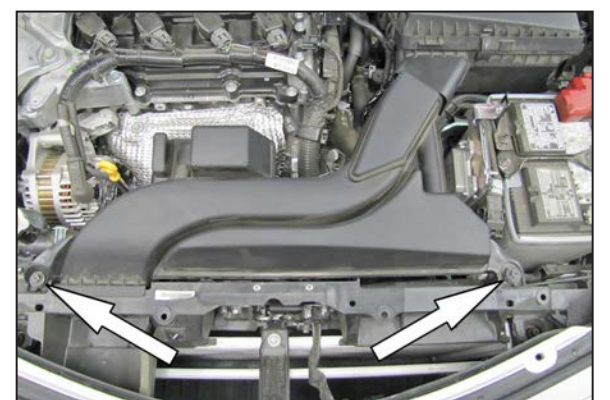

5. Remove the two bolts securing the fresh air intake to the core support and then remove the fresh air intake.
NOTE: These bolts will be reused in a later step.



6. Loosen the hose clamp securing the intake hose to the air filter housing.



7. Remove the bolt securing the air box to the bracket on the shock tower then lift up the air box to remove it from the vehicle.



8. Release the spring clamp securing the crank case vent hose to the intake plenum and then disconnect the hose from the plenum.

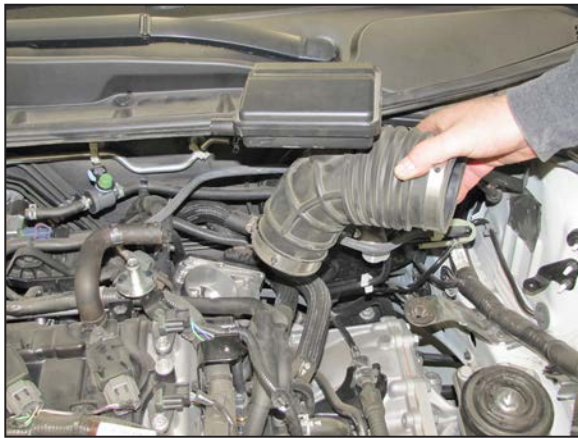

9. Loosen the hose clamp securing the intake hose to the throttle body and then remove the hose from the vehicle.
NOTE: K&N Engineering, Inc., recommends that customers do not discard factory air intake.



10. Install the coupling hose (084036) onto the throttle body and secure with the provided hose clamp.

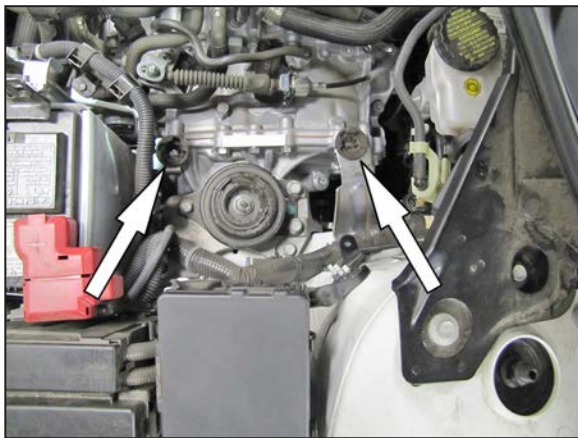

11. Remove the two air box mounting grommets from the mounting brackets shown.



12. Mount the two rubber mounted studs to the air box mounting brackets as shown.
NOTE: One of the 1/2" tall stud is to be mounted in the rear location and one of the 1" tall stud is to be mounted in the front location. Be sure to use two fender washers and one rubber washer with each stud.

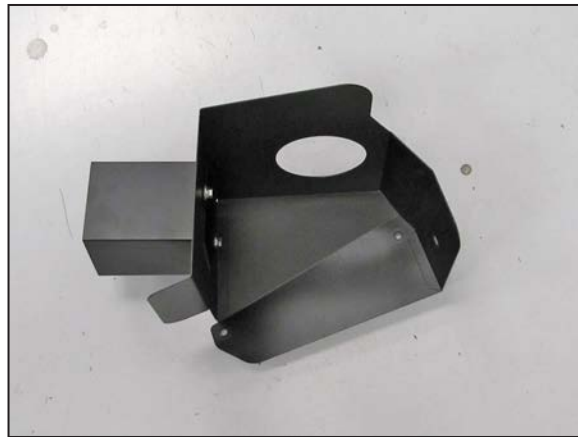

13. Install the fresh air intake scoop into the Heat shield and secure with the provided hardware.



14. Install the remaining 1" tall rubber mounted stud onto the heat shield mounting bracket (26606) as shown.



15. Install the remaining 1/2" long stud onto the upper air box mounting bracket as shown.



16. Install the bracket assembly onto the heat shield as shown and secure with the provided hardware.

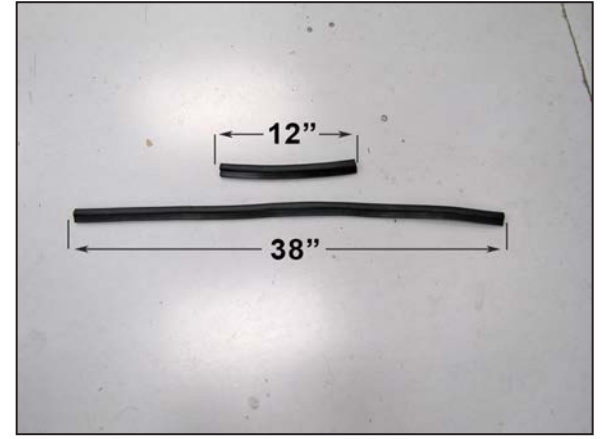

17. Cut the provided edge trim into two sections. One section should be cut to 12" long and the next section should be cut to 38" long.

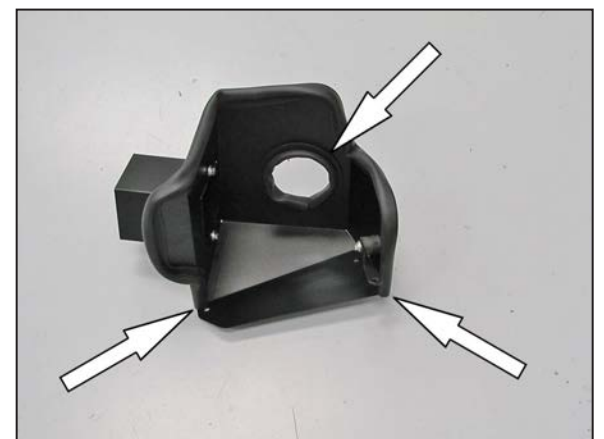

18. Install the 12" long section into the hole of the heat shield and install the 38" long section around the outside of the heat shield.



19. Install the heat shield assembly onto the rubber mounted studs and secure with the provided hardware.



20. Remove the mass air sensor from the factory air box.



21. Install the mass air sensor into the K&N® intake tube and secure with the provided hardware.



22. Install the 90° vent fitting into the K&N® intake tube as shown.

NOTE: Plastic NPT fittings are easy to cross thread. Install the vent fitting “hand” tight, then turn it two complete turns with a wrench.



23. Install the provided hose mender into the provided crank case vent hose.



24. Install the crank case vent hose assembly onto the 90° fitting as shown.



25. Pass the intake tube through the heat shield and then install it into the hose at the throttle body. Then secure the tube with the provided hose clamp.



26. Connect the factory crank case vent hose to the hose mender and secure with the factory clamp.

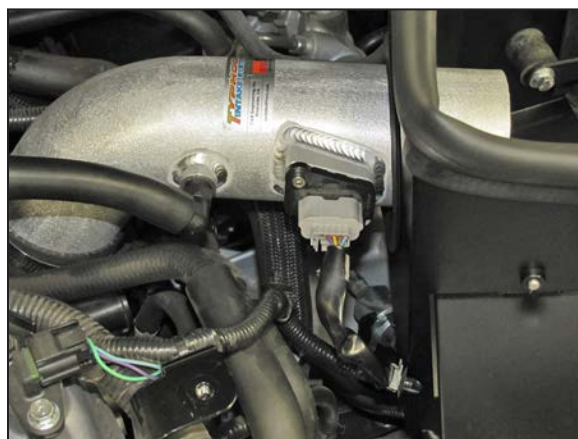

27. Reconnect the mass air sensor electrical connection.



28. Install the K&N® air filter and secure with the provided hose clamp.



29. Install the fresh air intake scoop and secure with the factory hardware.



30. Install the core support cover and secure with the factory pins.



31. Install the engine cover and secure with the factory hardware.



32. Reconnect the vehicle's negative battery cable. Double check to make sure everything is tight and properly positioned before starting the vehicle.

33. The C.A.R.B. exemption sticker, (attached), must be visible under the hood so that an emissions inspector can see it when the vehicle is required to be tested for emissions. California requires testing every two years, other states may vary.

34. It will be necessary for all K&N® high flow intake systems to be checked periodically for realignment, clearance and tightening of all connections. Failure to follow the above instructions or proper maintenance may void warranty.

ROAD TESTING:

1. Start the engine with the transmission in neutral or park, and the parking brake engaged. Listen for air leaks or odd noises. For air leaks secure hoses and connections. For odd noises, find cause and repair before proceeding. This kit will function identically to the factory system except for being louder and much more responsive.

2. Test drive the vehicle. Listen for odd noises or rattles and fix as necessary.

3. If road test is fine, you can now enjoy the added power and performance from your kit.

4. K&N Engineering, Inc., requires cleaning the intake system's air filter element every 100,000 miles. When used in dusty or off-road environments, our filters will require cleaning more often. We recommend that you visually inspect your filter once every 25,000 miles to determine if the screen is still visible. When the screen is no longer visible some place on the filter element, it is time to clean it. To clean and re-oil, purchase our filter Recharger® service kit, part number 99-5050 or 99-5000 and follow the easy instructions.