



TYPHOON INTAKE SYSTEMS

INSTALLATION INSTRUCTIONS

69-6502TR
MITSUBISHI
2006-2011 Eclipse
V6-3.8L

TOOLS NEEDED:

- Ratchet
- Long Extension
- 10mm Socket
- Flat blade Screwdriver
- Phillips Head Screwdriver
- Pliers
- 10mm Wrench
- 10mm Socket
- 12mm Socket
- 3mm Allen
- 4mm Allen

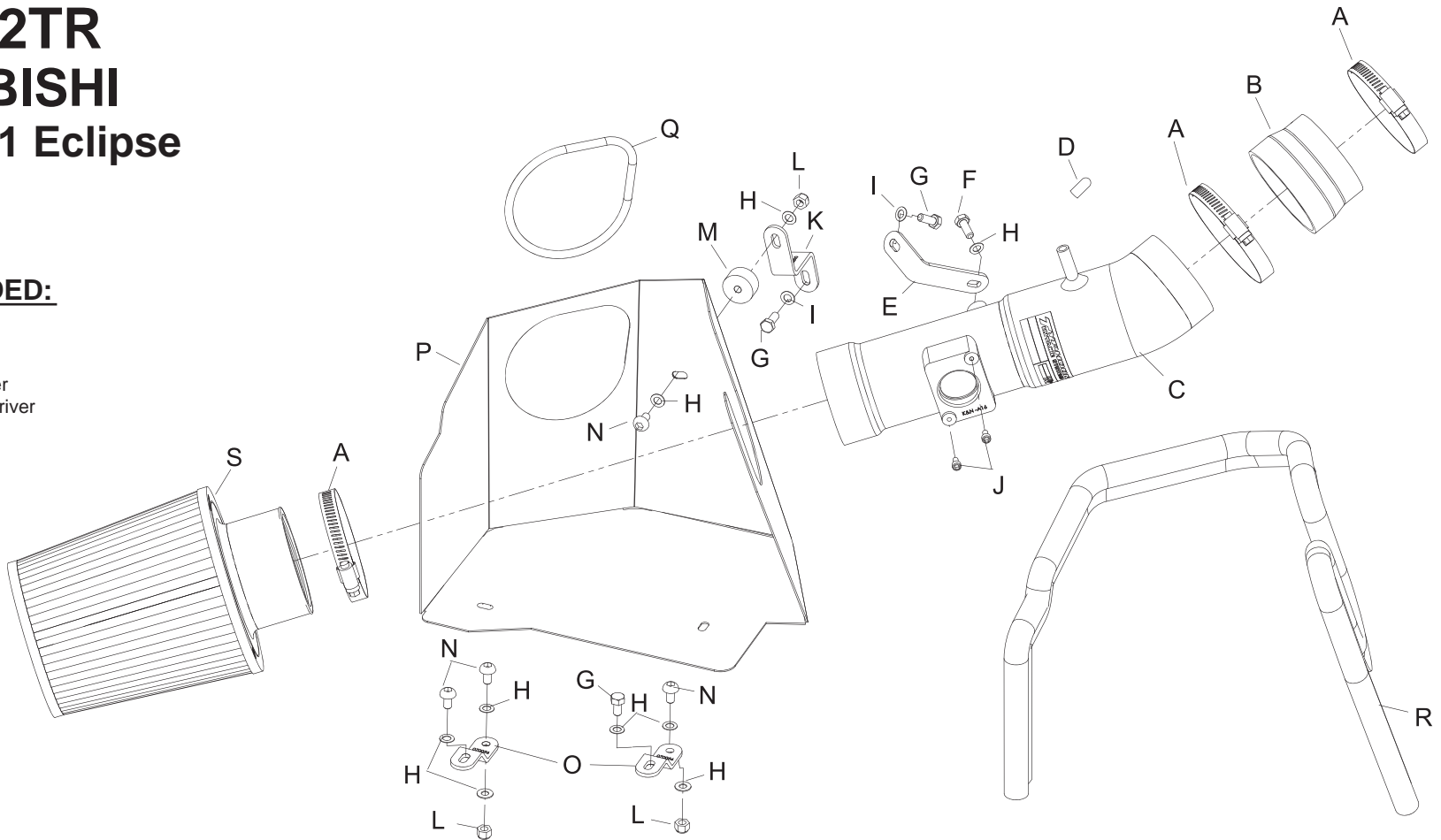

PARTS LIST:

Description	Qty.	Part #	Description	Qty.	Part #	Description	Qty.	Part #
A Hose Clamp #44	3	08560	H Washer; 6mm Wave	9	08277	O Bracket; "Z", Stl.	2	070056
B Hose; 2-3/4" to 3" x 2" L	1	084036	I Washer; Flat	2	08269	P Heat Shield; Stl.	1	07344
C Tube; 3" OD x 14-3/4" L	1	27511	J Bolt; m4-0.07 8mm, A/H Cap	2	07733	Q Edge Trim; 1/16" Gap, 13-1/2"L	1	8-3014
D Cap; 5/16"OD x 5/32"ID x 11/16" H	1	08282	K Bracket; "Z", Stl.	1	010033	R Edge Trim; 3/4" Top Loc, 44"L	1	102486
E Bracket; "L", Stl.	1	020012	L Nut; 6mm Nylock, Hexhead	3	07512	S Air Filter	1	RU-4730
F Bolt; M6x1.00x12mm., Hexhead	1	07727	M Stud; M/F 1/2"L x 1"W, M6x1.00	1	070228			
G Bolt; 6mm-1.00x16mm	3	07812	N Bolt; M6x1.00" 12mm Bttnhd.	4	07794			

NOTE: FAILURE TO FOLLOW INSTALLATION INSTRUCTIONS AND NOT USING THE PROVIDED HARDWARE MAY DAMAGE THE INTAKE TUBE, THROTTLE BODY AND ENGINE.

TO START:

1. Turn off the ignition and disconnect the negative battery cable.
NOTE: Disconnecting the negative battery cable erases pre-programmed electronic memories. Write down all memory settings before disconnecting the negative battery cable. Some radios will require an anti-theft code to be entered after the battery is reconnected. The anti-theft code is typically supplied with your owner's manual. In the event your vehicles' anti-theft code cannot be recovered, contact an authorized dealership to obtain your vehicles anti-theft code.

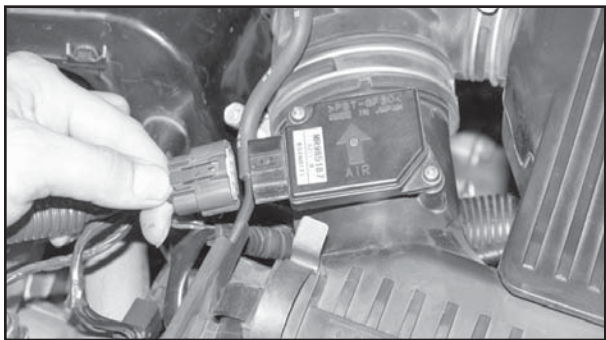

2. Disconnect the MAF sensor harness from the MAF sensor.

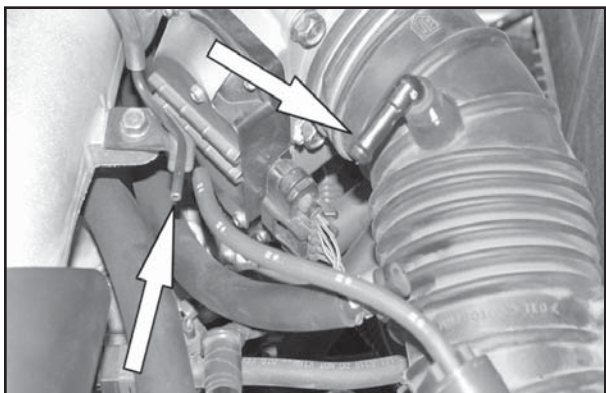

3. Disconnect the crank case vent (CCV) hose and fresh air intake door vacuum switching valve hose, then loosen the hose clamps at the throttle body.

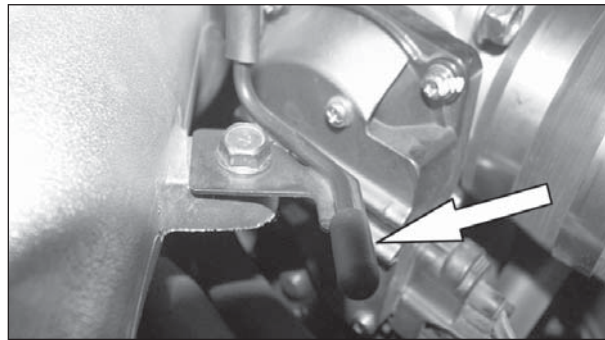

3a. Plug the fresh air intake door vacuum port with the provided rubber cap.

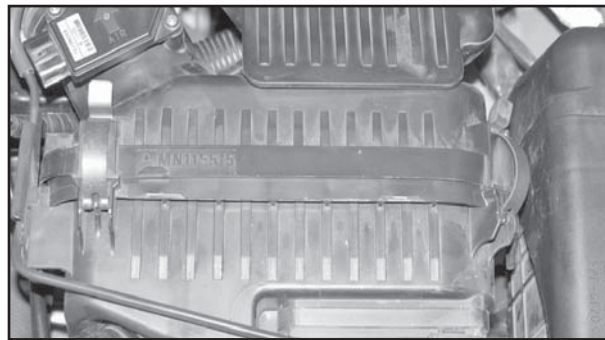

4. Unclip the two clips that hold the air box together.

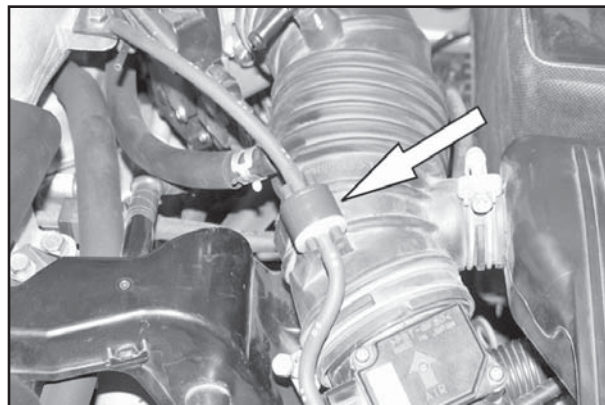

5. Unclip the Vacuum Switching Valve hose from the stock intake tube.

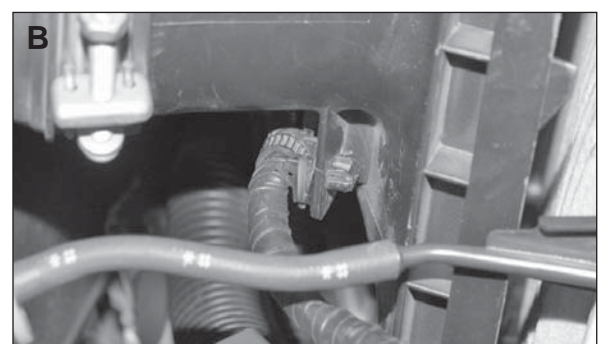
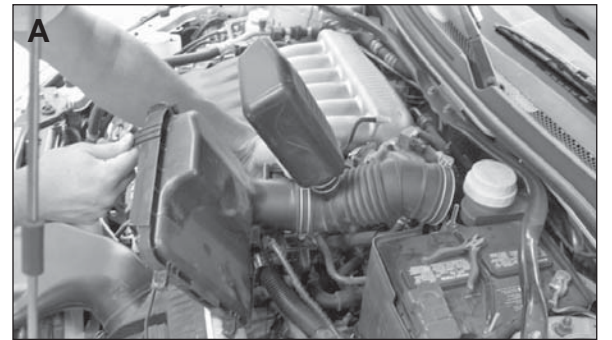

6. Lift the upper air box and turn over (A), then unclip the MAF sensor wire harness (B).



7. Remove the upper air box and intake tube from the vehicle.

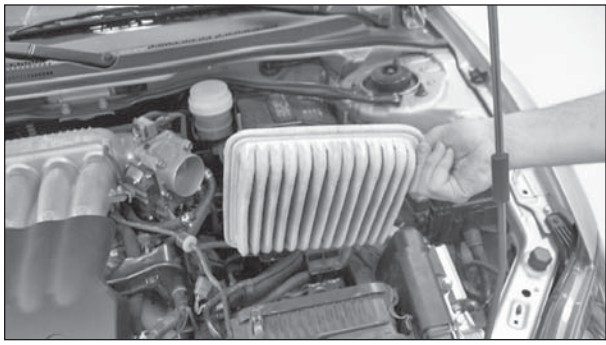

8. Remove the stock air filter.



9. Loosen and remove the 2 screws that hold the air inlet duct in place.

NOTE: The screws will be reused in a later step.

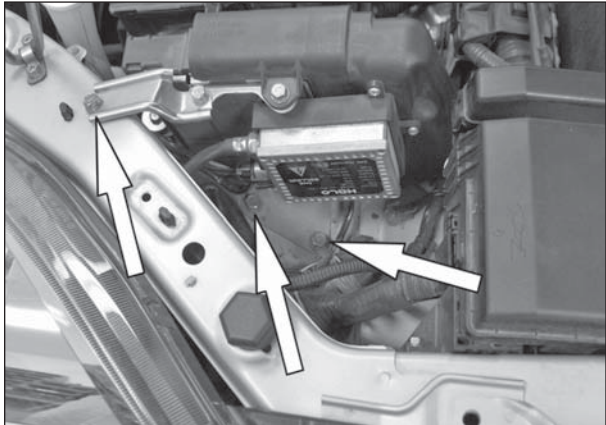

10. Loosen the three bolts that secure the ECU in place.

NOTE: Bolts will be reused in a later step.

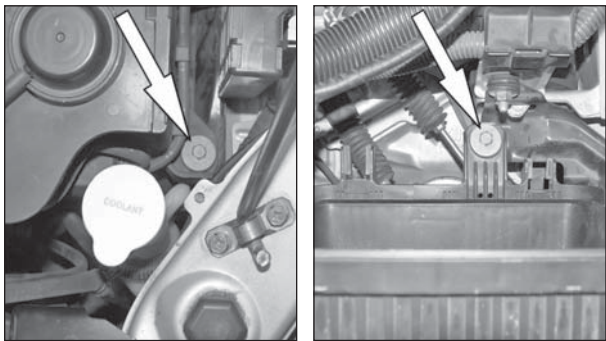

11. Loosen and remove the two bolts that secure the lower air box.

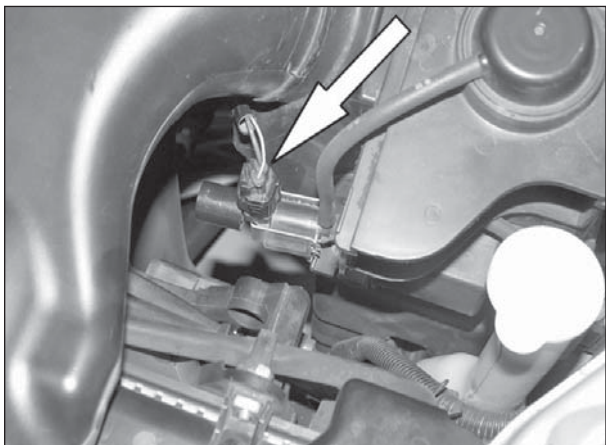

12. Disconnect the fresh air intake door vacuum switch electrical connection.

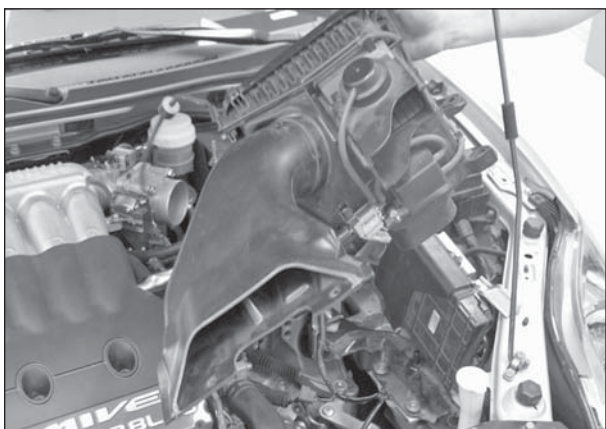

13. Lift the lower air box, pulling up to the left to unclip it.

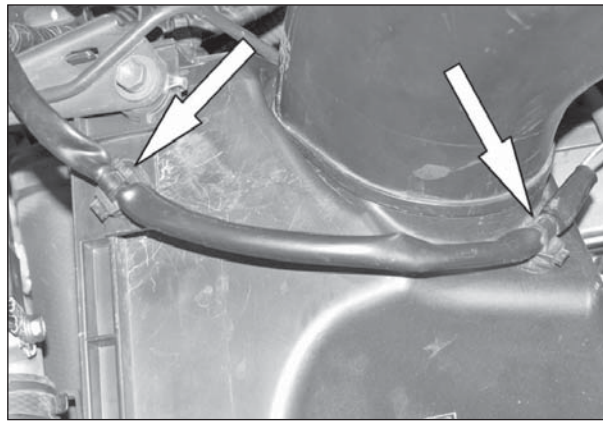

14. Turn the lower air box sideways, then unclip the two clips that secure the wire harness. Remove the lower air box from the vehicle.

NOTE: K&N Engineering, Inc., recommends that customers do not discard factory air intake.

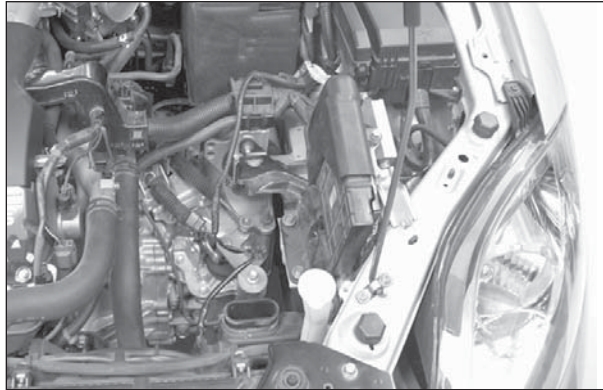

15. Re-secure the ECU bolts loosened in step #10.

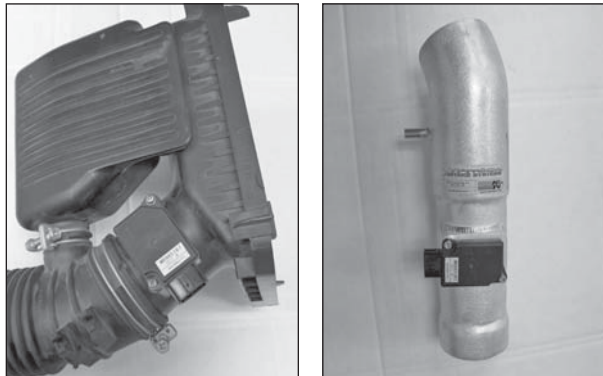

16. Remove the two screws securing the MAF sensor to the factory air box. Install the MAF sensor into the K&N® intake tube with the provided hardware.



17. Loosen and remove the bolt that secures the fresh air intake door switching valve solenoid to the lower air box.

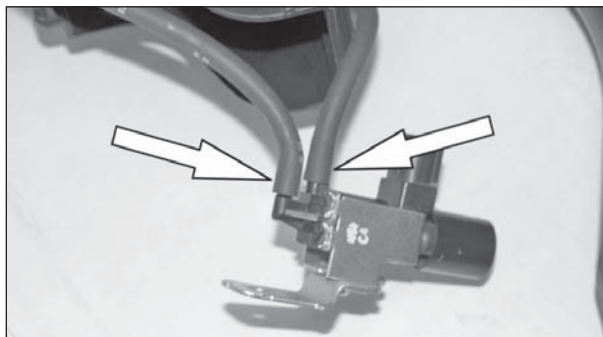

18. Disconnect the vacuum lines from the fresh air door vacuum switching valve.

NOTE: These vacuum lines will no longer be needed.



19. Unclip and remove the air inlet duct from the lower air box.

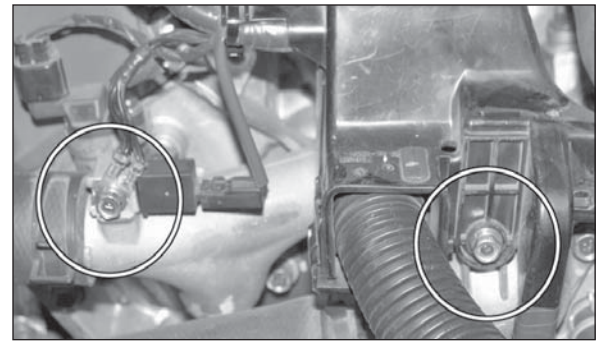

20. Loosen and remove the two specified bolts. (Ground and wire harness)

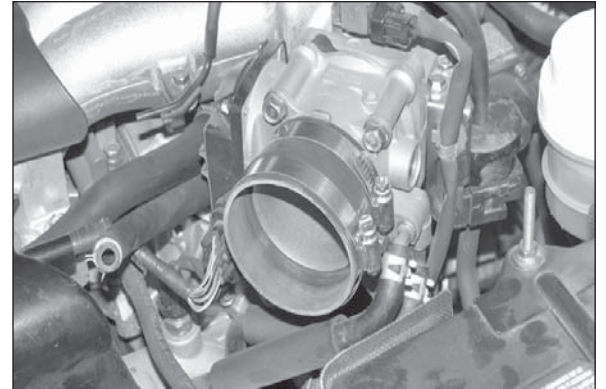

21. Install the provided silicone hose and hose clamps onto the throttle body as shown.

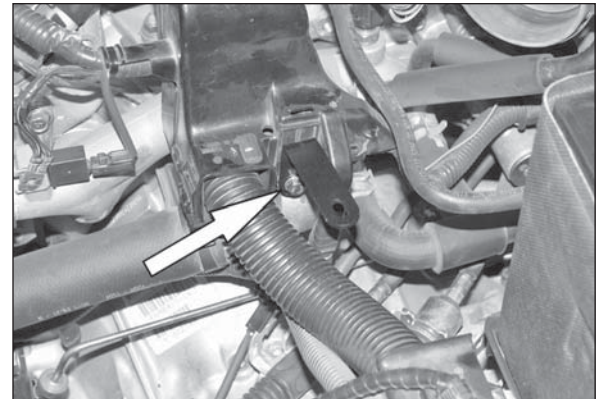

22. Install the "L" Bracket onto the wire harness bracket with the provided hardware.

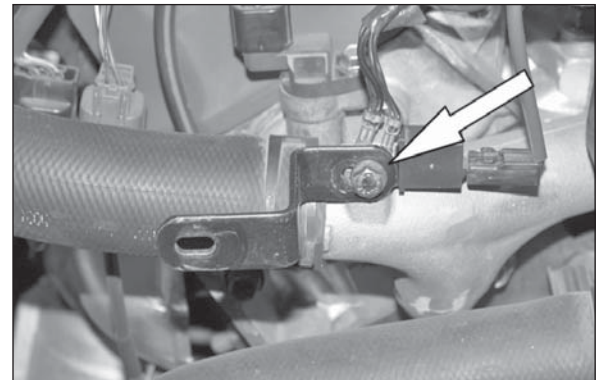

23. Install the "Z" bracket onto the ground with the provided hardware.



24. Install the small edge trim into the hole, then attach the large edge trim around the heat shield.



25. Install the vibration mount on the back side of the heat shield using the provided hardware as shown.

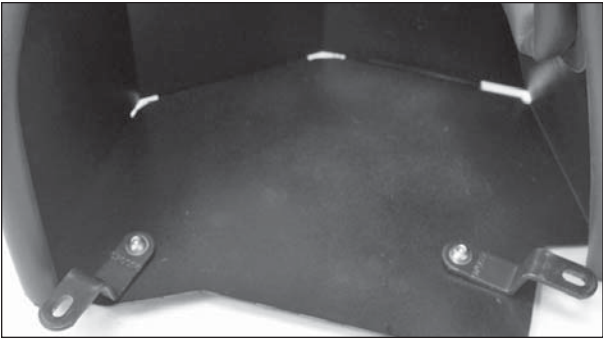

26. Install the "Z" brackets on the base of the heat shield with the provided hardware.

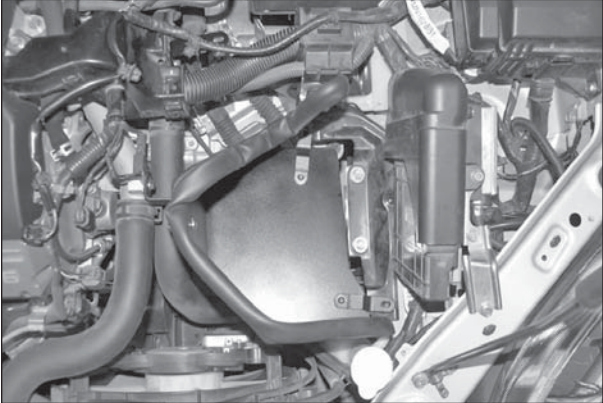

27. Install the heat shield into the engine bay, attach the side brackets to the vibration mount of the heat shield as shown.

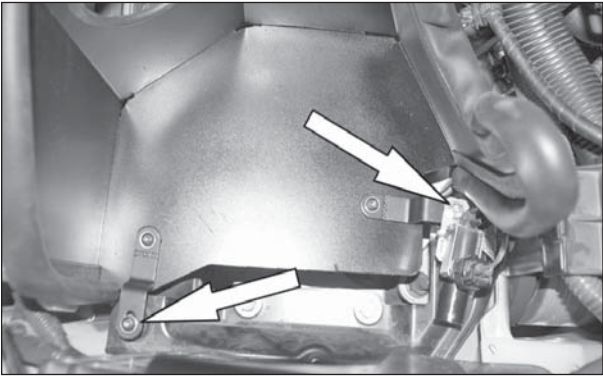

28. Attach the front bracket to the threaded hole on the stock air box mounting point. Attach the fresh air intake door switching valve solenoid and the rear bracket to the other threaded hole with the provided hardware.

NOTE: There will no longer be vacuum lines attached to the switching valve since the fresh air intake door has now been removed from the vehicle.

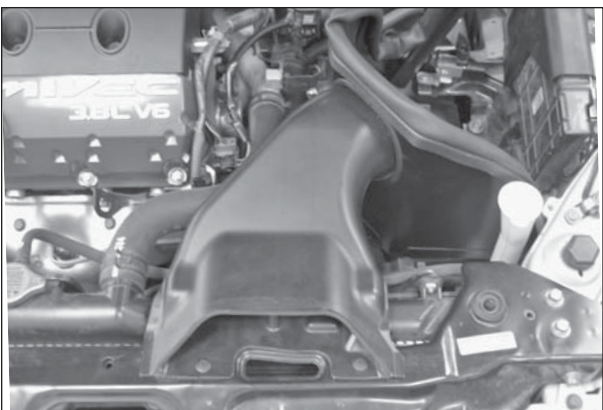

29. Install the factory air inlet duct, and secure with the two screws removed during step # 9. Adjust for fit and clearance, then tighten the heat shield mounting hardware.

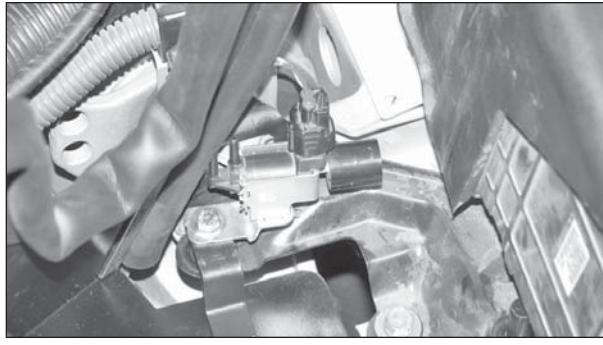

30. Reconnect the fresh air intake door vacuum switching valve solenoid electrical connection.

NOTE: There will no longer be vacuum lines attached to the switching valve since the fresh air intake door has now been removed from the vehicle.

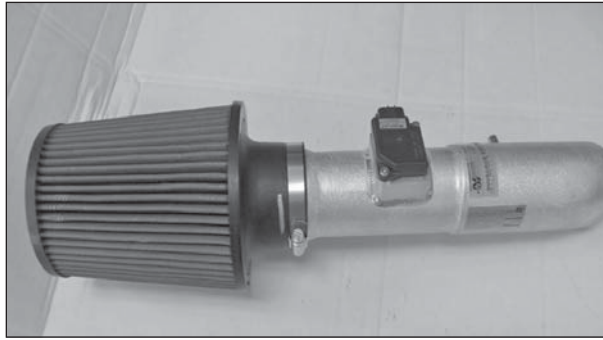

31. Install the K&N® air filter onto the intake tube as shown.

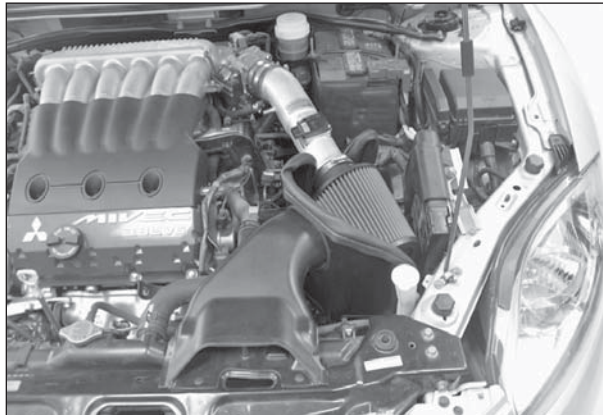

32. Install the K&N® intake tube with the provided hardware as shown. Adjust for best fit and clearance, then tighten all hardware, and hose clamps.

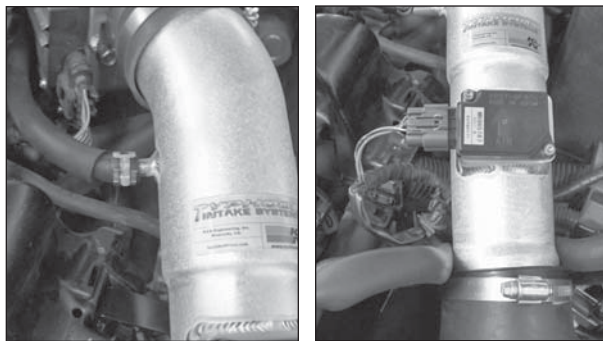

33. Reconnect the crank case vent hose and wire harness to the MAF sensor.



34. Reconnect the vehicle's negative battery cable. Double check to make sure everything is tight and properly positioned before starting the vehicle.

35. The C.A.R.B. exemption sticker, (attached), must be visible under the hood so that an emissions inspector can see it when the vehicle is required to be tested for emissions. California requires testing every two years, other states may vary.

36. It will be necessary for all K&N® high flow intake systems to be checked periodically for realignment, clearance and tightening of all connections. Failure to follow the above instructions or proper maintenance may void warranty.

ROAD TESTING:

1. Start the engine with the transmission in neutral or park, and the parking brake engaged. Listen for air leaks or odd noises. For air leaks secure hoses and connections. For odd noises, find cause and repair before proceeding. This kit will function identically to the factory system except for being louder and much more responsive.

2. Test drive the vehicle. Listen for odd noises or rattles and fix as necessary.

3. If road test is fine, you can now enjoy the added power and performance from your kit.

4. K&N Engineering, Inc., requires cleaning the intake system's air filter element every 100,000 miles. When used in dusty or off-road environments, our filters will require cleaning more often. We recommend that you visually inspect your filter once every 25,000 miles to determine if the screen is still visible. When the screen is no longer visible some place on the filter element, it is time to clean it. To clean and re-oil, purchase our filter Recharger® service kit, part number 99-5050 or 99-5000 and follow the easy instructions.