

# K&N TYPHOON INTAKE SYSTEMS

## INSTALLATION INSTRUCTIONS

69-6032TS

MAZDA

2014-17 Mazda 6 / Mazda 3

L4-2.5L

### TOOLS NEEDED:

Ratchet  
Extension  
10mm socket  
10mm wrench  
Flat Blade Screw Driver  
2.5MM allen key

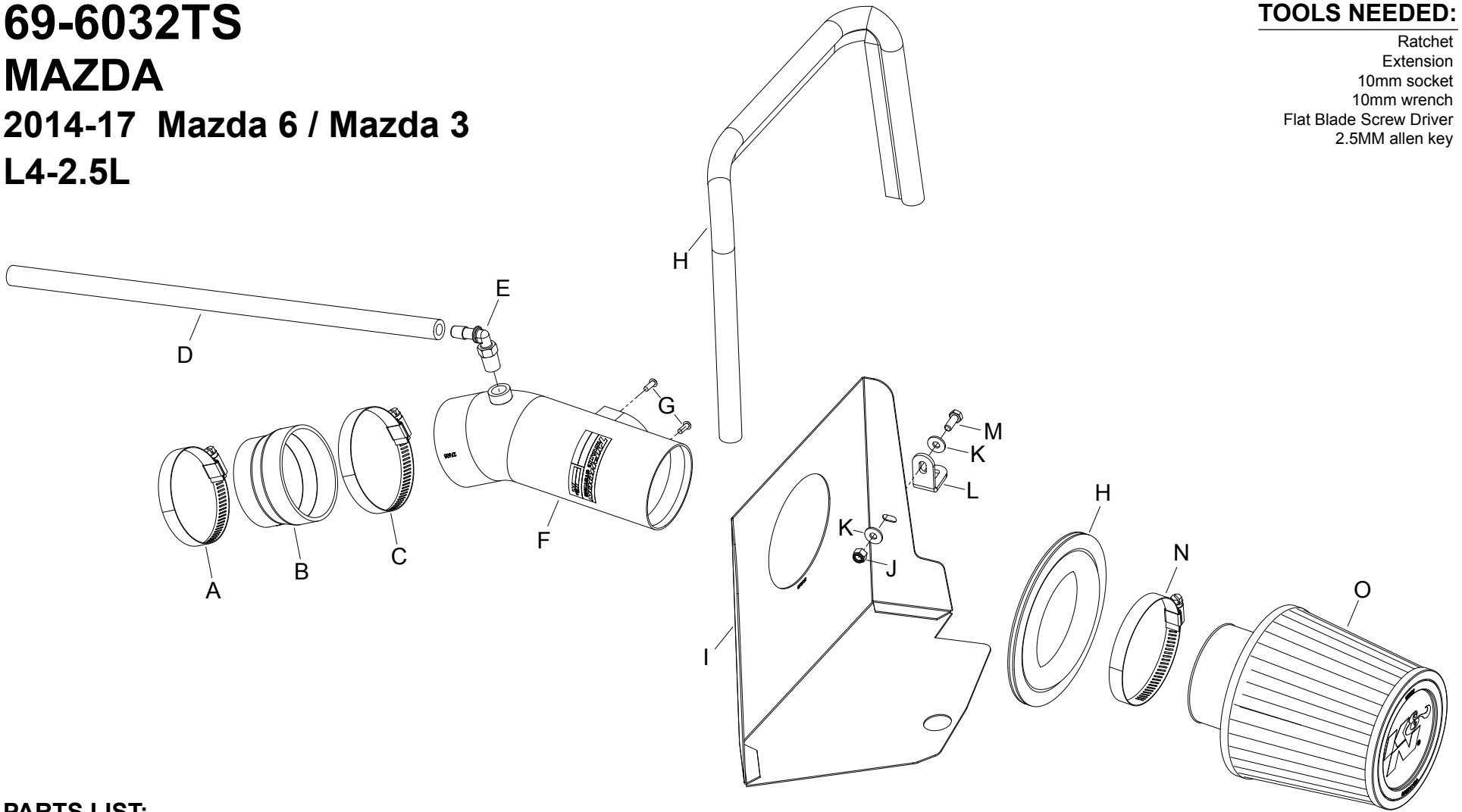

### PARTS LIST:

Description	Qty.	Part #	Description	Qty.	Part #	Description	Qty.	Part #
A HOSE CLAMP #48	1	08601	F INTAKE TUBE	1	27605TS	K WASHER; 6MM FLAT, SS	2	08269
B HOSE; 3" TO 2-3/4" ID X 2" L	1	084036	G SCREW; M4- .7 X 12, BUTTON	2	07726	L BRACKET; "L" 69-6032, STL	1	064313
C HOSE CLAMP #44 STAINLESS	1	08560	H EDGE TRIM (44")	1	102486	M BOLT; 6MM-1.00 X 16MM, SS	1	07812
D HOSE; 3/8" ID X 17" L	1	08404	I HEAT SHIELD	1	073151	N HOSE CLAMP #52	1	08610
E VENT; 1/4NPT, 90DEG., 3/8"	1	08523	J NUT; 6MM NYLOCK, HEXHEAD	1	07512	O AIR FILTER	1	RU-4990

**NOTE: FAILURE TO FOLLOW INSTALLATION INSTRUCTIONS AND NOT USING THE PROVIDED HARDWARE MAY DAMAGE THE INTAKE TUBE, THROTTLE BODY AND ENGINE.**

### TO START:

1. Turn off the ignition and disconnect the negative battery cable.  
**NOTE: Disconnecting the negative battery cable erases pre-programmed electronic memories. Write down all memory settings before disconnecting the negative battery cable. Some radios will require an anti-theft code to be entered after the battery is reconnected. The anti-theft code is typically supplied with your owner's manual. In the event your vehicles anti-theft code cannot be recovered, contact an authorized dealership to obtain your vehicles anti-theft code.**



2. Lift up and remove the engine cover.



3. Disconnect the mass air sensor electrical connection and unhook the wiring harness from the air box.



4. Disconnect the crank case vent tube from the valve cover port.



5. Remove the two bolts securing the fresh air inlet duct to the core support.



6. Loosen the hose clamp securing the intake tube to the throttle body.





7. Disconnect the intake tube from the throttle body and then lift up the complete intake assembly and remove it from the vehicle.

**NOTE: K&N Engineering, Inc., recommends that customers do not discard factory air intake.**



8. Install the heat shield mounting bracket (064313) onto the heat shield as shown using the provided hardware.

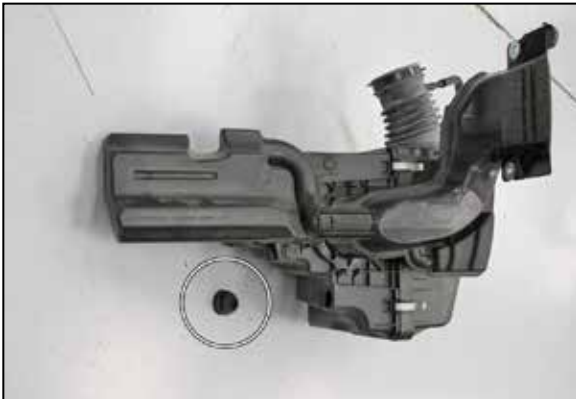

9. Remove one of the mounting grommets from the factory air box.



10. Install the mounting grommet into the heat shield as shown.

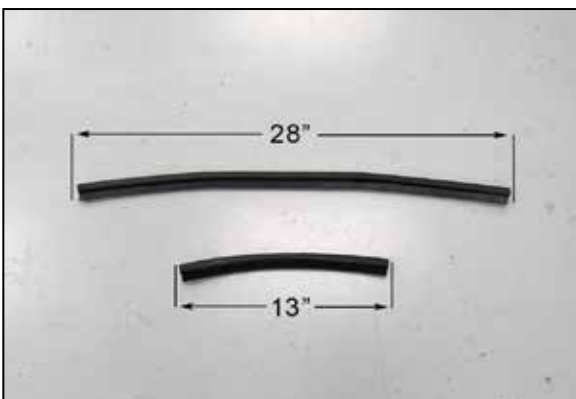

11. Cut the provided edge trim into two sections, one section should be 13" long. One section should be 28" long



12. Install the provided edge trim onto the heat shield as shown. The 13" long section will be installed into the hole of the heat shield.



13. Remove the ECU mounting bracket bolt shown. **NOTE: This bolt will be reused in the next step.**



14. Install the heat shield assembly so that the mounting grommet is on the air box mounting stud and the bracket aligns with the bolt hole from the previous step, secure the heat shield using the factory bolt from the previous step.



15. Install the provided coupling hose (084036) onto the throttle body and secure with the provided hose clamp.



16. Install the provided 90° vent fitting into the K&N® intake tube as shown. **NOTE: Plastic NPT fittings are easy to cross thread. Install the vent fitting "hand" tight, then turn it two complete turns with a wrench.**



17. Remove the mass air sensor from the factory air box.



18. Install the mass air sensor into the K&N® intake tube and secure with the provided hardware.



19. Install the K&N® Air filter through the heat shield, install the intake tube into the air filter and then into the coupling hose. Adjust the tube and filter for best fit and then secure with the provided hose clamps.

**NOTE: Drycharger® air filter wrap; part # RX-4990DK is available to purchase separately.**



20. Install the provided crank case vent hose onto the valve cover port and then onto the fitting installed into the K&N® intake tube.

**NOTE: Some trimming of the crank case vent hose will be necessary.**



21. Reconnect the mass air sensor electrical connection.



22. Reinstall the engine cover.



23. Reconnect the vehicle's negative battery cable. Double check to make sure everything is tight and properly positioned before starting the vehicle.

24. It will be necessary for all K&N® high flow intake systems to be checked periodically for realignment, clearance and tightening of all connections. Failure to follow the above instructions or proper maintenance may void warranty.

#### ROAD TESTING:

1. Start the engine with the transmission in neutral or park, and the parking brake engaged. Listen for air leaks or odd noises. For air leaks secure hoses and connections. For odd noises, find cause and repair before proceeding. This kit will function identically to the factory system except for being louder and much more responsive.

2. Test drive the vehicle. Listen for odd noises or rattles and fix as necessary.

3. If road test is fine, you can now enjoy the added power and performance from your kit.

4. K&N Engineering, Inc., requires cleaning the intake system's air filter element every 100,000 miles. When used in dusty or off-road environments, our filters will require cleaning more often. We recommend that you visually inspect your filter once every 25,000 miles to determine if the screen is still visible. When the screen is no longer visible some place on the filter element, it is time to clean it. To clean and re-oil, purchase our filter Recharger® service kit, part number 99-5050 or 99-5000 and follow the easy instructions.