



TYPHOON INTAKE SYSTEMS

INSTALLATION INSTRUCTIONS

69-6030-1TFK

MAZDA

2003-11 RX-8

Rotary 1.3L

NOTE: C.A.R.B. E.O. # D-269-37 APPLIES ONLY TO 2003-2009 MODEL YEAR VEHICLES

NOTE: for EU and UK vehicles, the comments 'automatic transmission' and 'manual transmission' do not apply. Instead, substitute 'SP-vehicles' and 'HP-vehicles' respectively and follow instructions accordingly.

TOOLS NEEDED:

- Flat Blade Screwdriver
- Phillips Screwdriver
- Pliers
- Ratchet
- 10mm Socket
- 10" Extension
- 3mm Allen
- 4mm Allen
- 5mm Allen

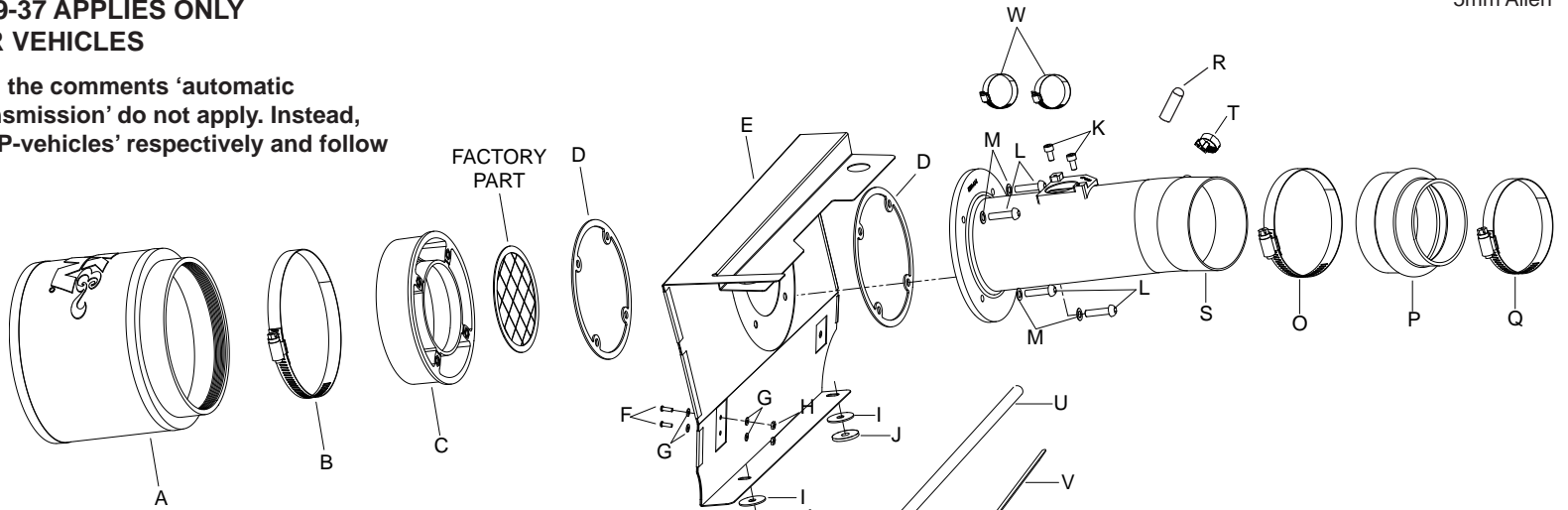

PARTS LIST:

Description	Qty.	Part #	Description	Qty.	Part #	Description	Qty.	Part #
A Carbon Inverted Cone Air Filter	1	RU-5123	I Washer; 1"OD	2	08160	R Tip; 3/8"ODx1/4"IDx1-1/4"l Rubber	1	08215
B Hose Clamp; #104	1	08697	J Washer; Rubber 1"OD	2	21685	S Intake Tube	1	27329
C Adaptor; #451, 5-1/2"OD	1	08916	K Bolt; M4 - 0.7 X 8mm L, Cha, SS	2	07733	T Hose Clamp; #004 Mini	1	21850
D Gasket;	2	10395	L Bolt; M6-1.00 X 25mm Bh, SS	4	07729	U Breather Hose	1	08139
E Heat Shield;	1	07333	M Washer; 6mm Wave, SS	4	08277	V Zip Tie	1	21589
F Screw; M3-0.5 X 6mm, Phillips, SS	2	09375	O Hose Clamp; #60	1	08628	W Hose Clamp #6 Mini	2	08407
G Washer; 3mm, Flat, SS	4	21706	P Hose; 3" - 3-1/2" ID Step Hump	1	084079			
H Nut; M3 - 0.5, Hex, SS	2	07509	Q Hose Clamp; #48	1	08601			

NOTE: FAILURE TO FOLLOW INSTALLATION INSTRUCTIONS AND NOT USING THE PROVIDED HARDWARE MAY DAMAGE THE INTAKE TUBE, THROTTLE BODY AND ENGINE.

TO START:

1. Turn off the ignition and disconnect the negative battery cable.
NOTE: Disconnecting the negative battery cable erases pre-programmed electronic memories. Write down all memory settings before disconnecting the negative battery cable. Some radios will require an anti-theft code to be entered after the battery is reconnected. The anti-theft code is typically supplied with your owner's manual. In the event your vehicles' anti-theft code cannot be recovered, contact an authorized dealership to obtain your vehicles anti-theft code.



2. Remove engine cover as shown.



3. Disconnect the mass air sensor electrical connection as shown.



4. On manual transmission vehicle, (automatic transmission vehicles, go to step 7.) disconnect the vacuum switch electrical connection and unclip the wire from the mass air sensor housing as shown.
NOTE: Some EU and UK SP-vehicles may have this connection, even if they don't have the vacuum switch!

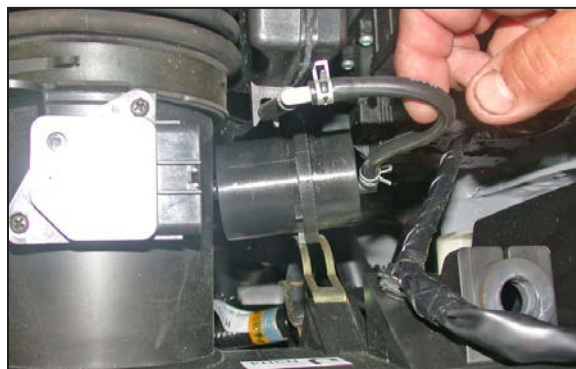

5. On manual transmission vehicles, remove the vacuum canister from the clip on the side of the airbox assembly.



6. On manual transmission vehicles, remove the vacuum hose from the resonator as shown.



7. Disconnect the three hoses from the stock intake tube as shown.
NOTE: On some models there is only 2 vacuum lines.



8. Loosen the hose clamp at the mass air sensor as shown.

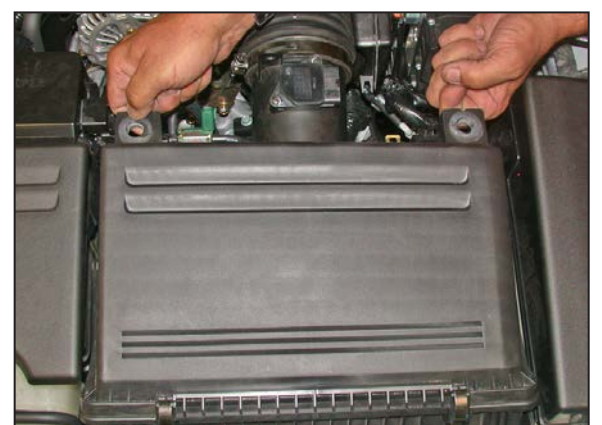

9. Lift up on the back of the air cleaner to release the airbox assembly from the stock grommets.



10. Push back on the front of the air cleaner to release the air cleaner from the stock grommets.



11. Lift the air cleaner upwards, then disconnect the vacuum hose from the vacuum switch (automatic transmission vehicles disregard the vacuum switch hose and go to step 12.) as shown.

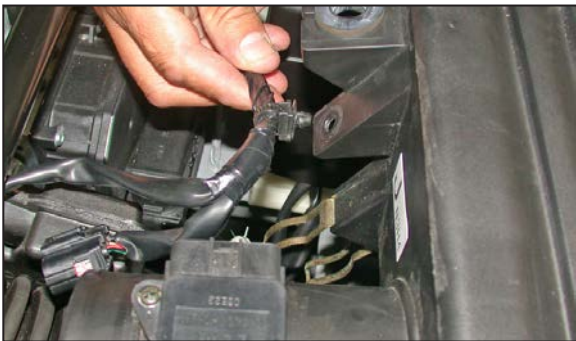

12. Using a pair of pliers, unclip the wire harness from the air cleaner assembly as shown.



13. On manual transmission vehicles (automatic transmission vehicles go to step 14) turn the air cleaner upside down to remove the nut that secures the vacuum switch to the air cleaner assembly then remove the vacuum switch.



14. Loosen the hose clamp and pull the intake tube off of the throttle body, rotate the tube and unclip the vacuum hose from the intake tube as shown.



15. Remove the intake hose as shown.

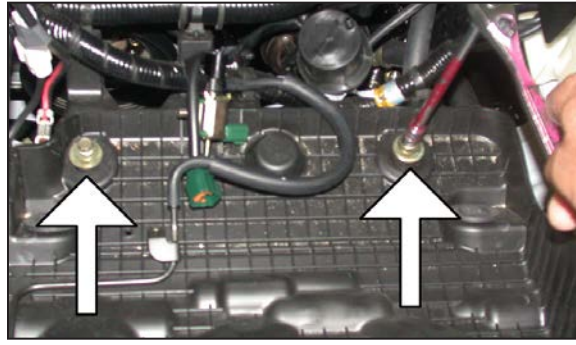

16. Remove the two lower bolts that secure the airbox assembly support brackets as shown. **NOTE: K&N Engineering, Inc., recommends that customers do not discard factory air intake.**



17. Remove the mass air sensor from the air cleaner housing as shown.



18. Remove the stock grommets from the air cleaner assembly as shown.



19. On manual transmission vehicles (automatic transmission vehicles go to step 20) remove the vacuum canister clip from the air cleaner assembly.

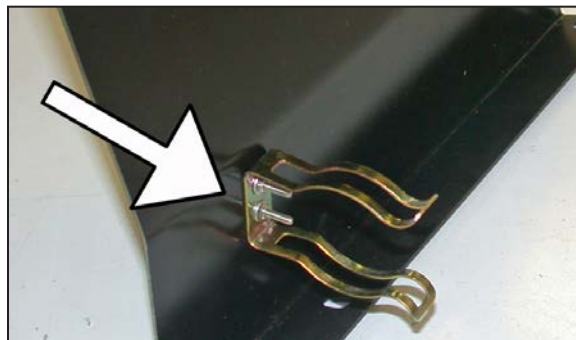

20. Manual trans only, install the canister clip from step 19 onto the heat shield using the provided hardware.

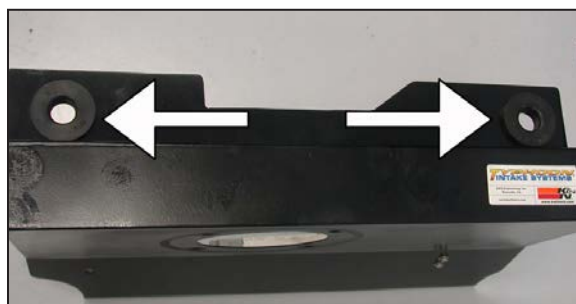

21. Install the stock grommets from the stock air cleaner onto the heat shield as shown.



22. Remove the stock screen from the air cleaner cover as shown.



23. Install the stock screen and the provided gasket onto the back of the provided filter adapter as shown.



24. Install the heat shield and the remaining gasket onto the filter adaptor as shown.

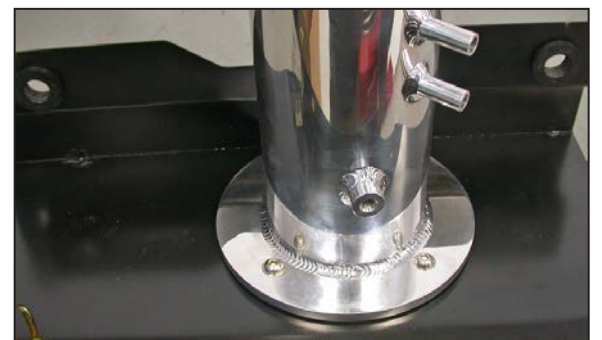

25. Install the K&N® intake tube onto the heat shield and secure with the provided hardware as shown.



26. Install the mass air sensor into the intake tube using the provided hardware as shown.

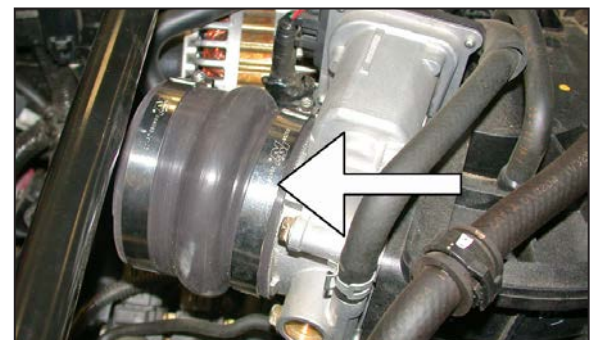

27. Install the silicone hose and hose clamps onto the throttle body as shown.

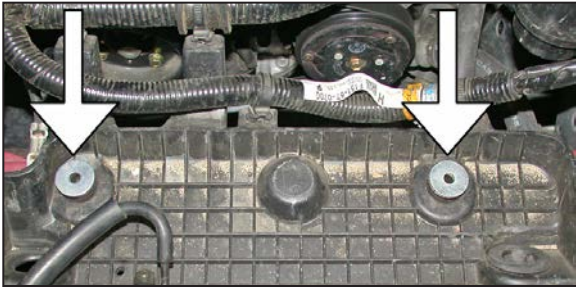

28. Install the provided rubber washers and fender washers onto the existing air cleaner mounts as shown.



29. Install the heat shield into the vehicle and slide the intake tube into the silicone hose as shown.

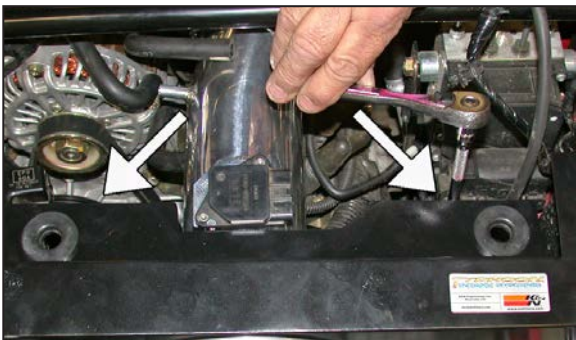

30. Secure the heat shield to the stock air cleaner mounts using the stock bolts as shown.

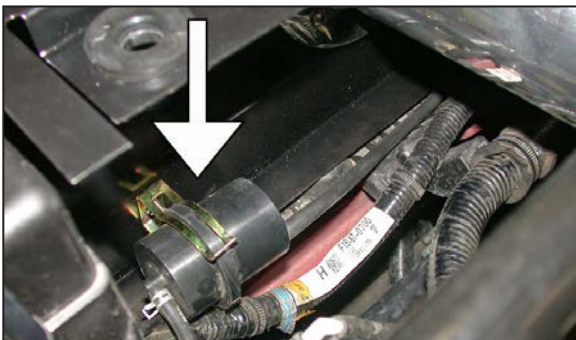

31. Manual trans only, slide the canister from step 5 into the canister clip as shown.

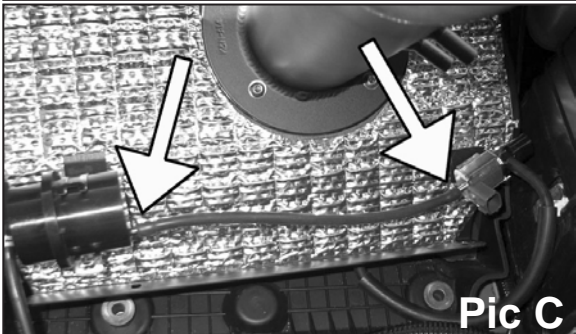
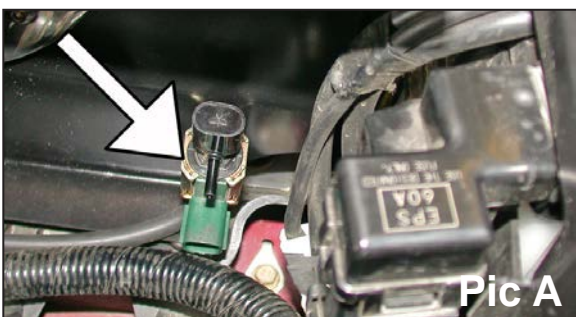

32. Manual transmission vehicles install the vacuum switching valve onto the back side of the heat shield (Pic A) and secure using the stock nut (Pic B) as shown.

NOTE: If the hose between canister and switch proves too short, replace it with the provided breather hose as shown (Pic C).

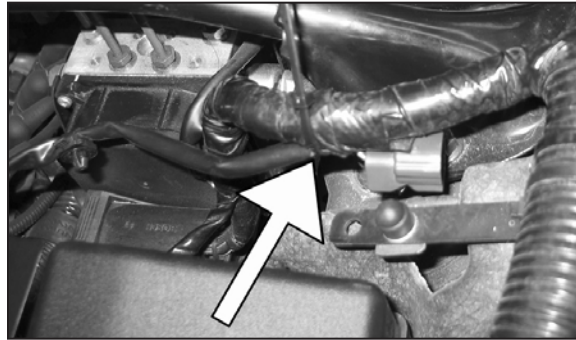

33. EU and UK SP-vehicles with the dummy electrical connection described in step 4, secure the excess electrical connector away using the zip tie provided as shown.

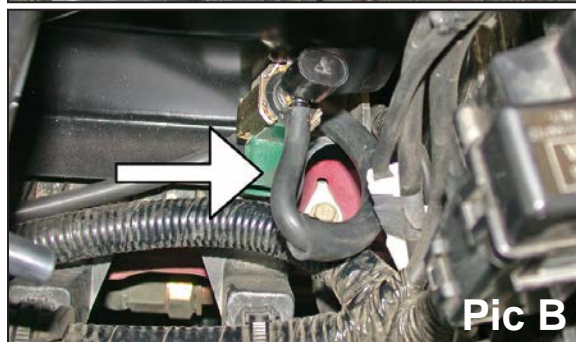

34. Manual transmission vehicles reroute the vacuum hose through the corner of the heat shield (Pic A) and reconnect the hose to the vacuum switching valve (Pic B) as shown.

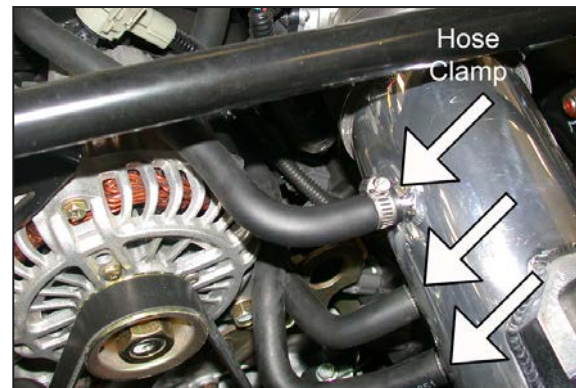

35. Connect the three vent lines to the K&N® intake tube and secure with the provided hose clamps.

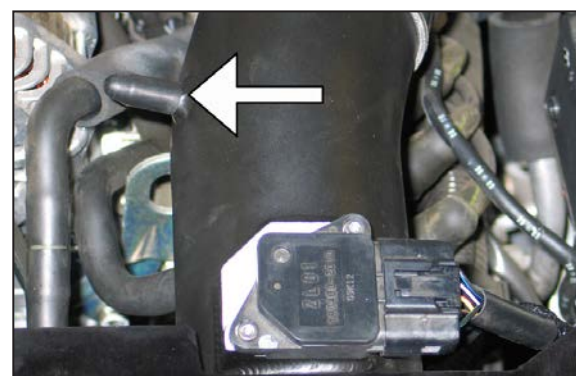

35a. On models with only two vent lines, install the provided cap plug on the K&N® intake tube and secure with the provided hose clamp.



36. Install the K&N® air filter and secure using the provided hose clamp as shown.

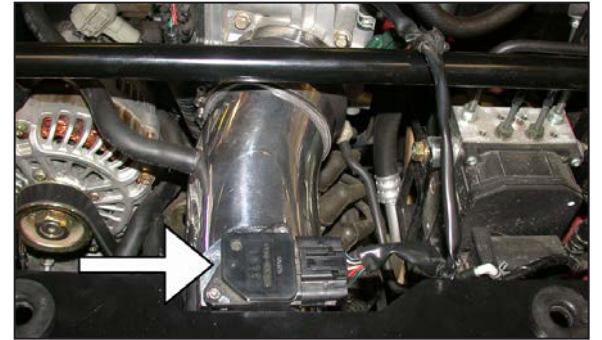

37. Reconnect the mass air sensor electrical connection as shown.



38. Reconnect the vacuum switching valve electrical connection as shown.



39. Install the engine cover as shown.

40. Reconnect the vehicle's negative battery cable. Double check to make sure everything is tight and properly positioned before starting the vehicle.

41. The C.A.R.B. exemption sticker, (attached), must be visible under the hood so that an emissions inspector can see it when the vehicle is required to be tested for emissions. California requires testing every two years, other states may vary.

42. It will be necessary for all K&N® high flow intake systems to be checked periodically for realignment, clearance and tightening of all connections. Failure to follow the above instructions or proper maintenance may void warranty.

ROAD TESTING:

1. Start the engine with the transmission in neutral or park, and the parking brake engaged. Listen for air leaks or odd noises. For air leaks secure hoses and connections. For odd noises, find cause and repair before proceeding. This kit will function identically to the factory system except for being louder and much more responsive.

2. Test drive the vehicle. Listen for odd noises or rattles and fix as necessary.

3. If road test is fine, you can now enjoy the added power and performance from your kit.

4. K&N Engineering, Inc., suggests checking the air filter element periodically for excessive dirt build-up. When the element becomes covered in dirt (or once a year), service it according to the instructions on the Recharger® service kit, part number 99-5050 or 99-5000.