

K&N TYPHOON INTAKE SYSTEMS

INSTALLATION INSTRUCTIONS

69-6013TTK

MAZDA

2010-12 3

L4-2.5L

TOOLS NEEDED:

Ratchet
Extension
10mm Socket
9/16" Socket
Flat Blade Screwdriver
Phillips Screwdriver
10mm Wrench
8mm Socket
3mm Allen Wrench

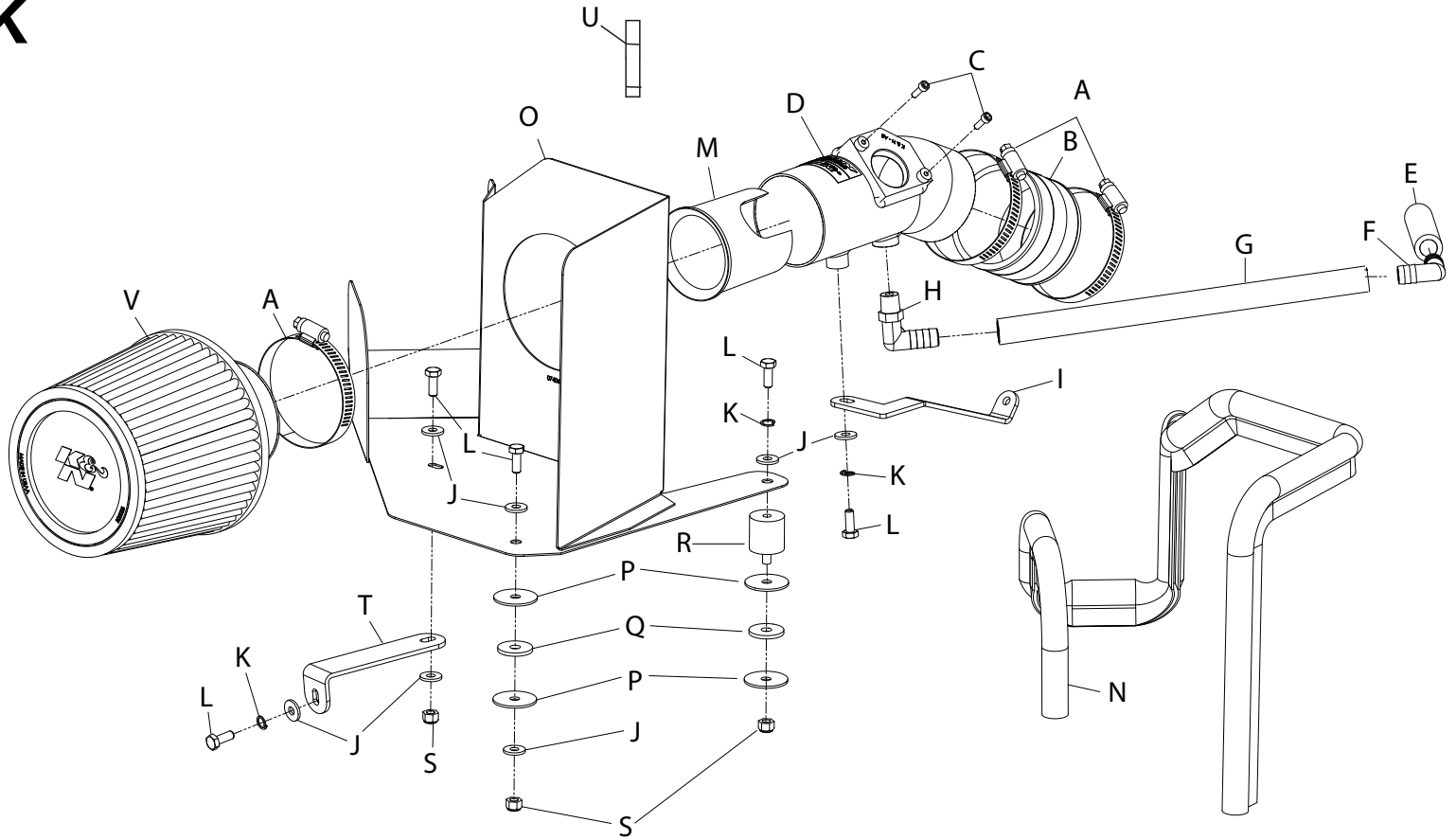

PARTS LIST:

Description	Qty.	Part #	Description	Qty.	Part #	Description	Qty.	Part #
A Hose Clamp #44	3	08577	I Bracket; "Z"	1	083137	Q Washer; 1"x.300x.100 Rubber	2	21685
B Hose; 2-3/4" ID X 2"L	1	08756	J Washer; 1/4"IDx5/8"OD-SAE	7	08275	R Stud; Mount, M6x1, 1" T, M/F	1	02033
C Bolt; M4-0.07 8MM, A/H Cap	2	07733	K Washer; 1/4" LOCK, ZN	3	08198	S Nut; 6MM Nylock,	3	07512
D Intake Tube	1	27474	L Bolt; 6MM-1.00 X 16MM, SS	5	07812	T Bracket;"L"	1	083138
E Hose; 1/2" ID X 3-1/2"L	1	087028	M Venturi, MAF Insert, 2.75"	1	9-479	U Super Glue	1	409
F Vent; 1/2 X 1/2 Elbow	1	08065	N Edge Trim (39")	1	102496	V Air Filter	1	RU-4960XD
G Hose; 1/2" ID X 20"L	1	08470	O Heat Shield	1	074069-1			
H Vent; 90°, 1/2" Hose, 1/4"NPT	1	08110	P Washer; 1.25D X .28	4	08151			

NOTE: FAILURE TO FOLLOW INSTALLATION INSTRUCTIONS AND NOT USING THE PROVIDED HARDWARE MAY DAMAGE THE INTAKE TUBE, THROTTLE BODY AND ENGINE.

TO START:

1. Turn off the ignition and disconnect the negative battery cable.

NOTE: Disconnecting the negative battery cable erases pre-programmed electronic memories. Write down all memory settings before disconnecting the negative battery cable. Some radios will require an anti-theft code to be entered after the battery is reconnected. The anti-theft code is typically supplied with your owner's manual. In the event your vehicles' anti-theft code cannot be recovered, contact an authorized dealership to obtain your vehicles anti-theft code.



2. Disconnect the mass air sensor electrical connection and then unhook the harness from the airbox mounting location.



3. Release the two upper airbox retaining clips and loosen the hose clamp which secures the intake tube to the throttle body.



4. Unhook the crankcase vent line from the valve cover port as shown.



5. Remove the upper airbox assembly from the vehicle as shown.



6. Remove the lower airbox mounting bolt shown.



7. Lift up the lower airbox and remove it from the vehicle as shown.

NOTE: K&N Engineering, Inc., recommends that customers do not discard factory air intake.



8. Remove the two airbox mounting grommets and the bolt shown.



9. Remove the lower rear throttle body mounting bolt shown.

NOTE: This bolt will be reused.



10. Install the tube mounting bracket (083137) onto the throttle body and secure with the factory bolt removed in step #9.



11. Install the provided silicone hose (08756) onto the throttle body and secure with the provided hose clamp.



12. Install the provided rubber mounted stud onto the airbox mounting bracket using the provided hardware as shown.

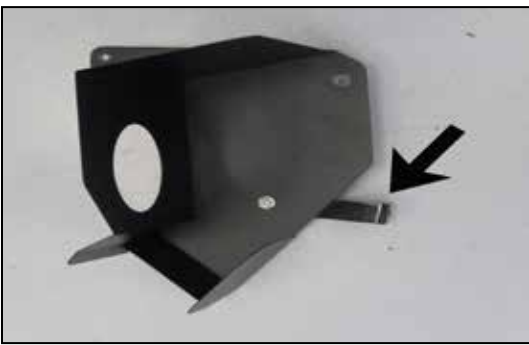

13. Install the provided heat shield mounting bracket (083138) onto the heat shield as shown. **NOTE: The bracket is to be mounted on the bottom of the heat shield.**



14. Install the edge trim onto the heat shield as shown. **NOTE: Some trimming of the edge trim will be necessary.**



15. Set the heat shield into position on the rubber mounted stud, and then secure the heat shield with the provided hardware.



16. Install the 90° vent fitting into the K&N® intake tube as shown.

NOTE: Plastic NPT fittings are easy to cross thread. Install the vent fitting "hand" tight, then turn it two complete turns with a wrench.



17. Remove the two screws which secure the mass air sensor into the factory airbox and then remove the mass air sensor as shown.



18. Install the mass air sensor into the K&N® intake tube and secure with the provided hardware.



19. Insert the venturi insert into the K&N® intake tube as shown.

NOTE: Apply a thin coat of the provided super glue to the lip of the venturi



20. Install the K&N® intake tube assembly into the silicone hose at the throttle body and align with the tube mounting bracket and then secure with the provided hardware and hose clamps.



21. Assemble the crankcase vent hoses and 90° barbed fitting as shown.



22. Install the short length of the crankcase vent hose onto the valve cover port and then attach the open end to the fitting installed into the K&N® intake tube.



23. Install the K&N® air filter onto the K&N® intake tube and secure with the provided hose clamp.



24. Reconnect the mass air sensor electrical connection.



25. Reconnect the vehicle's negative battery cable. Double check to make sure everything is tight and properly positioned before starting the vehicle.

26. It will be necessary for all K&N® high flow intake systems to be checked periodically for realignment, clearance and tightening of all connections. Failure to follow the above instructions or proper maintenance may void warranty.

ROAD TESTING:

1. Start the engine with the transmission in neutral or park, and the parking brake engaged. Listen for air leaks or odd noises. For air leaks secure hoses and connections. For odd noises, find cause and repair before proceeding. This kit will function identically to the factory system except for being louder and much more responsive.
2. Test drive the vehicle. Listen for odd noises or rattles and fix as necessary.
3. If road test is fine, you can now enjoy the added power and performance from your kit.
4. K&N Engineering, Inc., suggests checking the air filter element periodically for excessive dirt build-up. When the element becomes covered in dirt (or once a year), service it according to the instructions on the Recharger® service kit, part number 99-5050 or 99-5000