



TYPHOON INTAKE SYSTEMS

INSTALLATION INSTRUCTIONS

69-5304TS
HYUNDAI
2012-13 Veloster
L4-1.6L

TOOLS NEEDED:

Ratchet
 Extension
 Flat blade screw driver
 10mm socket
 4mm Allen wrench
 2.5mm Allen wrench
 9/16" wrench
 Pliers

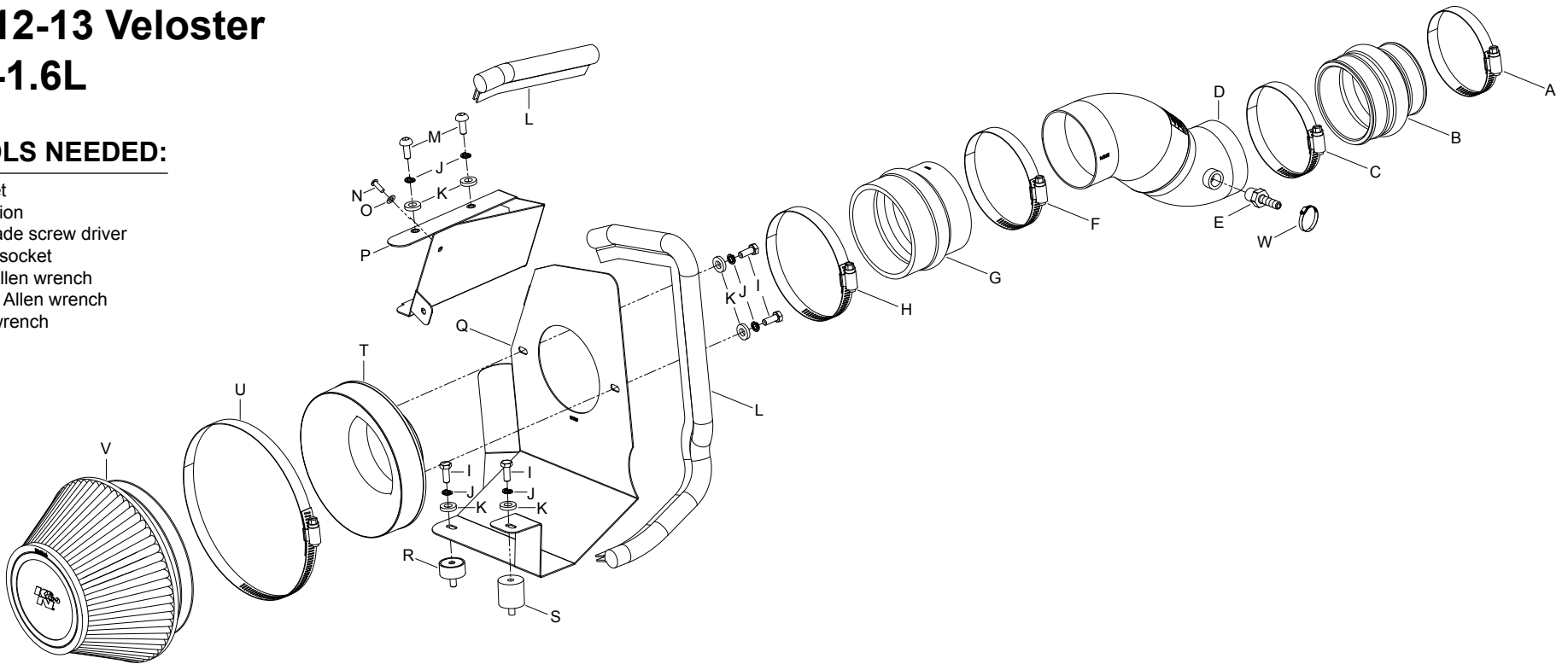

PARTS LIST:

Description	Qty.	Part #	Description	Qty.	Part #	Description	Qty.	Part #
A HOSE CLAMP #40	1	08554	I BOLT; 6MM-1.00 X 16MM, SS	4	07812	Q HEAT SHIELD	1	07389
B HOSE, HUMP 2.50/3.00 X 3.00"	1	5-574	J WASHER; M6 SPLIT LOCK ZINC	6	1-3025	R STUD; RUBBER MNT, M/F, 1/2"L	1	070228
C HOSE CLAMP # 48	1	08601	K WASHER; 1/4"ID X 5/8"OD, SAE	6	08275	S STUD;RUBBER MOUNT, M6 X 1	1	02033
D INTAKE TUBE	1	27574TS	L EDGE TRIM (30")	1	102489	T ADAPTER; UNIVERSAL, 6"	1	21512-1
E VENT; STRT, 3/8"HOSE, 1/4"	1	08047	M BOLT; M6 X 1.00 X 16MM, SS	2	07730	U HOSE CLAMP # 104	1	08697
F HOSE CLAMP #52	1	08610	N BOLT; M4 X .7 X 8MM, SS	1	07741	V AIR FILTER	1	RU-4600
G HOSE, HUMP 3.25/3.50 X 3.00	1	5-576	O WASHER; 4MM FLAT	1	08278	W HOSE CLAMP #6	1	08407
H HOSE CLAMP #56	1	08620	P HEAT SHIELD SCOOP	1	07388			

NOTE: FAILURE TO FOLLOW INSTALLATION INSTRUCTIONS AND NOT USING THE PROVIDED HARDWARE MAY DAMAGE THE INTAKE TUBE, THROTTLE BODY AND ENGINE.

TO START:

1. Turn off the ignition and disconnect the negative battery cable.
NOTE: Disconnecting the negative battery cable erases pre-programmed electronic memories. Write down all memory settings before disconnecting the negative battery cable. Some radios will require an anti-theft code to be entered after the battery is reconnected. The anti-theft code is typically supplied with your owner's manual. In the event your vehicles' anti-theft code cannot be recovered, contact an authorized dealership to obtain your vehicles anti-theft code.



2. Loosen the hose clamp securing the intake tube to the throttle body.



3. Disconnect the crank case vent hose from the factory intake tube.



4. Remove the three bolts securing the factory air box assembly onto the inner fender.



5. Remove the air box assembly from the vehicle.
NOTE: K&N Engineering, Inc., recommends that customers do not discard factory air intake.



6. Push in the center of the fresh air duct retaining clips and then remove the clips.



7. Remove the fresh air intake duct.

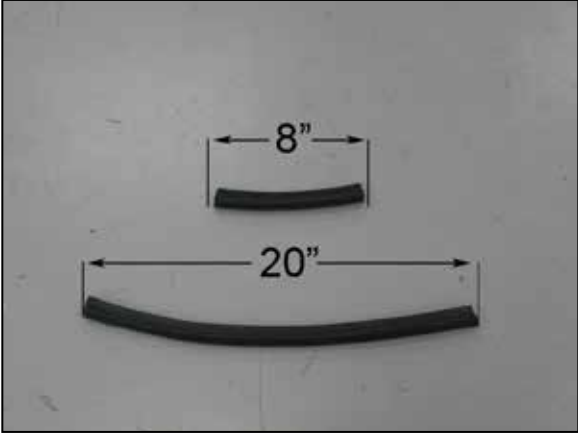

8. Cut the provided edge trim into two sections, one section will be 20" long and the shorter section will be 8" long.

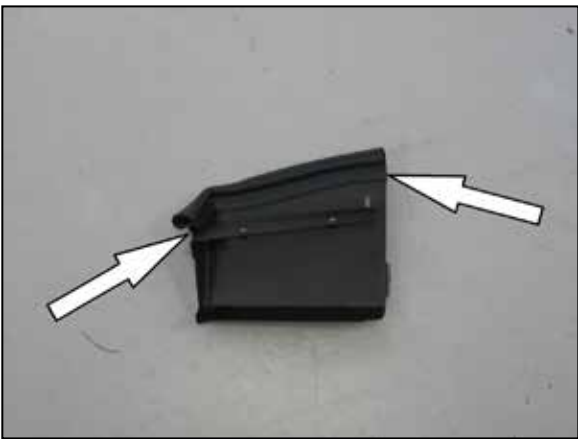

9. Install the 8" section onto the K&N® fresh air intake scoop as shown.

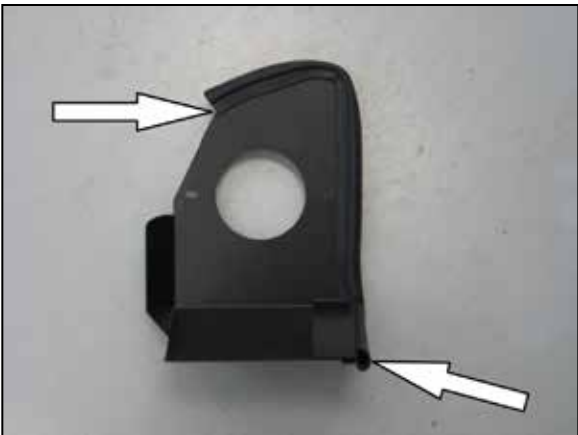

10. Install the 20" section onto the heat shield as shown.



11. Install the 1" rubber mounted stud into the rear factory air box mounting location as shown.



12. Install the 1/2" rubber mounted stud into the front factory air box mounting location as shown.



13. Set the heat shield into position on the rubber mounted studs and secure with the provided hardware.



14. Install the filter adapter into the K&N® air filter and secure with the provided hose clamp.



15. Install the filter assembly into the heat shield and secure with the rear mounting bolt provided only at this time.
NOTE: Precharger® air filter wrap; part # 22-8036PK is available to purchase separately.



16. Install the fresh air intake scoop and secure to the core support and heat shield/filter adapter with the provided hardware.



17. Install the provided silicone hump hose (5-574) onto the throttle body and secure with the provided hose clamp.



18. Install the provided silicone hump hose (5-576) onto the filter adapter and secure with the provided hose clamp.



19. Install the provided vent fitting into the K&N® intake tube as shown.
NOTE: Plastic NPT fittings are easy to cross thread. Install the vent fitting "hand" tight, then turn it two complete turns with a wrench.



20. Install the K&N® intake tube into the silicone hose at the throttle body fully then into the silicone hose at the filter adapter, adjust the tube for proper fit and then secure with the provided hose clamps.



21. Reroute the crank case vent line under the fuel line and then install it onto the crank case vent fitting on the intake tube. Secure with the provided hose clamp.



22. Reconnect the vehicle's negative battery cable. Double check to make sure everything is tight and properly positioned before starting the vehicle.

23. The C.A.R.B. exemption sticker, (attached), must be visible under the hood so that an emissions inspector can see it when the vehicle is required to be tested for emissions. California requires testing every two years, other states may vary.

24. It will be necessary for all K&N® high flow intake systems to be checked periodically for realignment, clearance and tightening of all connections. Failure to follow the above instructions or proper maintenance may void warranty.

ROAD TESTING:

1. Start the engine with the transmission in neutral or park, and the parking brake engaged. Listen for air leaks or odd noises. For air leaks secure hoses and connections. For odd noises, find cause and repair before proceeding. This kit will function identically to the factory system except for being louder and much more responsive.

2. Test drive the vehicle. Listen for odd noises or rattles and fix as necessary.

3. If road test is fine, you can now enjoy the added power and performance from your kit.

4. K&N Engineering, Inc., requires cleaning the intake system's air filter element every 100,000 miles. When used in dusty or off-road environments, our filters will require cleaning more often. We recommend that you visually inspect your filter once every 25,000 miles to determine if the screen is still visible. When the screen is no longer visible some place on the filter element, it is time to clean it. To clean and re-oil, purchase our filter Recharger® service kit, part number 99-5050 or 99-5000 and follow the easy instructions.