



TYPHOON INTAKE SYSTEMS

INSTALLATION INSTRUCTIONS

69-5302TTK
HYUNDAI
2010-12 Genesis Coupe
L4-2.0 Turbo

TOOLS NEEDED:

Ratchet
 Extension
 10mm
 Flat blade screwdriver
 10mm wrench
 5mm allen wrench
 Pliers

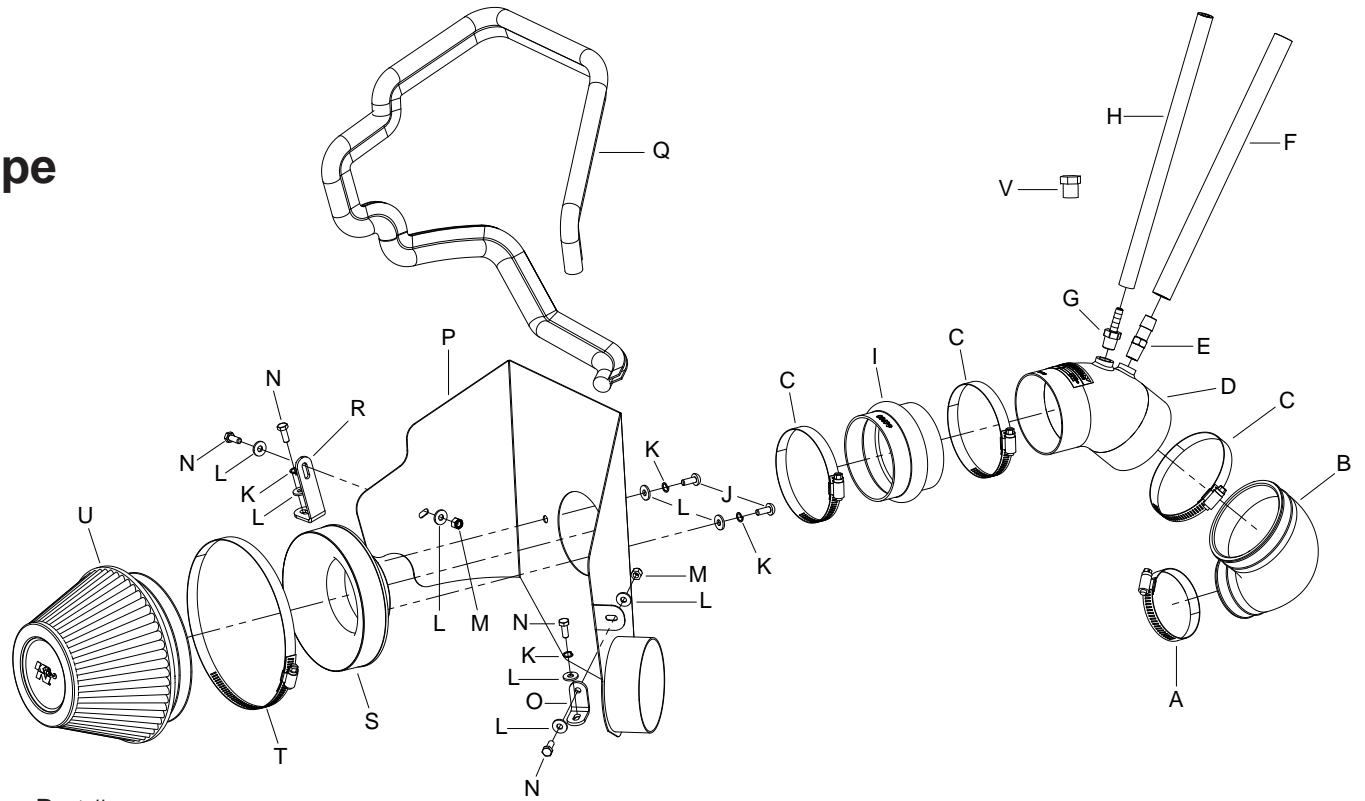

PARTS LIST:

Description	Qty.	Part #	Description	Qty.	Part #	Description	Qty.	Part #
A Hose Clamp #40	1	08554	I Hose; 3-1/2" ID X 2-1/2" L Hump	1	08699	Q Edge Trim (48")	1	102485
B Hose	1	08504	J Bolt; M6 X 1.00 X 16MM , Buttonhead, SS	2	07730	R Bracket; "L", FIN., TB/PC	1	070742
C Hose Clamp #56	3	08620	K Washer; 1/4" Lock, ZN	4	08198	S Adapter; Universal, 6" Filter 3.5" Coupler	1	21512-1
D Intake Tube	1	27482	L Washer; 1/4" ID X 5/8" OD - SAE	8	08275	T Hose Clamp #104	1	08697
E Vent; STRT 1/2" Hose, 1/4"NPT	1	080022	M Nut; 6MM Nylock, Hexhead, SS	2	07512	U Air Filter	1	RP-4600
F Hose; 1/2" ID X 12" L	1	087031	N Bolt; 6MM-1.00 X 16MM, SS	4	07812	V Plug; 1/4 NPT, Plastic, Black	1	08032
G Vent; STRT, 3/8"Hose, 1/4"NPT	1	08047	O Bracket; "L", SML, STL, TB/PC	1	070066			
H Hose; 3/8" ID X 12" L	1	08412	P Heat Shield	1	074081			

NOTE: FAILURE TO FOLLOW INSTALLATION INSTRUCTIONS AND NOT USING THE PROVIDED HARDWARE MAY DAMAGE THE INTAKE TUBE, THROTTLE BODY AND ENGINE.

TO START:

1. Turn off the ignition and disconnect the negative battery cable.

NOTE: Disconnecting the negative battery cable erases pre-programmed electronic memories. Write down all memory settings before disconnecting the negative battery cable. Some radios will require an anti-theft code to be entered after the battery is reconnected. The anti-theft code is typically supplied with your owner's manual. In the event your vehicles' anti-theft code cannot be recovered, contact an authorized dealership to obtain your vehicles anti-theft code.



2. Loosen the hose clamp securing the intake tube to the airbox, then disconnect the tube from the airbox.



3. Remove the three bolts securing the airbox to the inner fender.



4. Remove the airbox assembly from the vehicle.
NOTE: K&N Engineering, Inc., recommends that customers do not discard factory air intake.

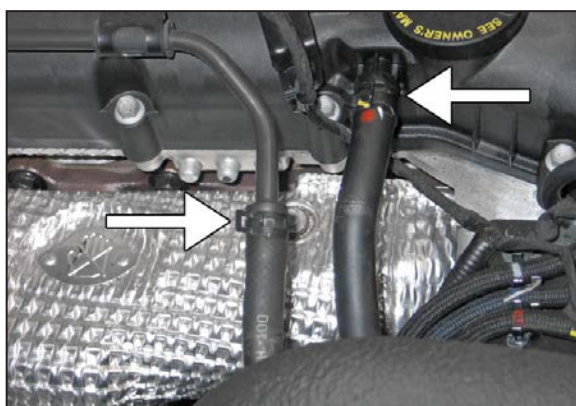

5. Disconnect the crankcase vent line and EVAP vent line at the connections shown.



6. Loosen the hose clamp securing the intake tube to the turbo inlet, then remove the intake tube from the vehicle.



7. Install the elbow silicone hose (08504) onto the turbo inlet as shown and secure with the provided hose clamp.

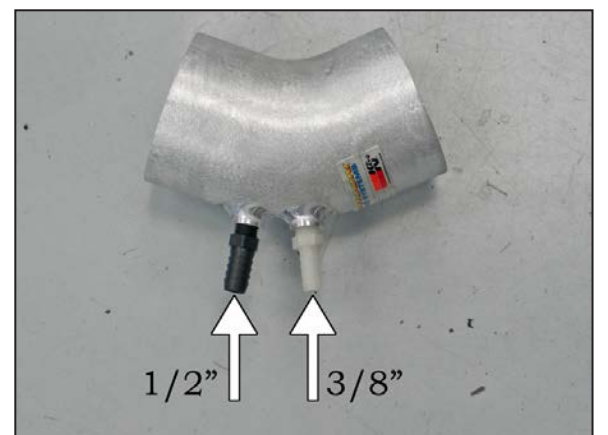

8. Install the provided vent fittings into the K&N® intake tube as shown.
NOTE: On automatic transmission equipped vehicles, the smaller 3/8" vent fitting will not be used and the 1/4 NPT plug should be installed.
NOTE: Plastic NPT fittings are easy to cross thread. Install the vent fitting "hand" tight, then turn it two complete turns with a wrench.



9. Install the K&N® intake tube into the silicone hose and secure with the provided hose clamp. **NOTE: Do not completely tighten the hose clamp at this time.**

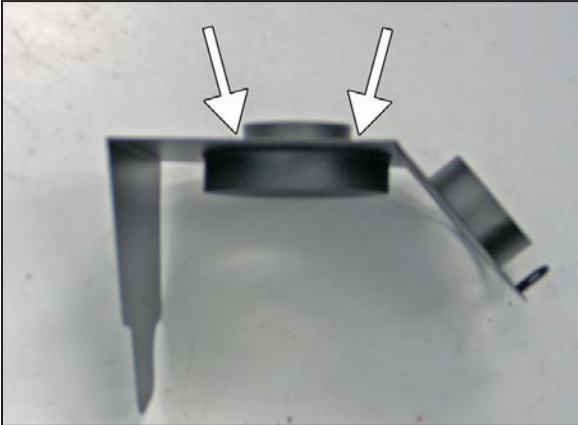

10. Install the provided filter adapter into the heat shield and secure with the provided hardware.

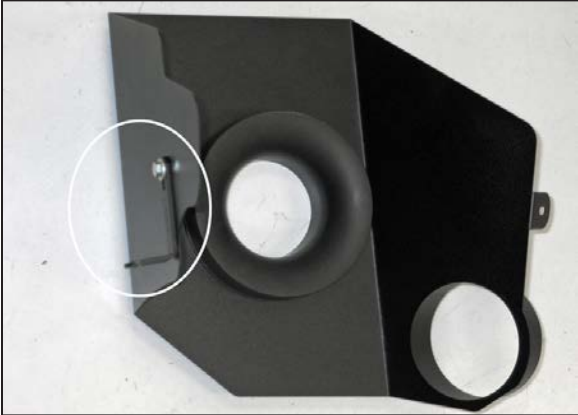

11. Install the provided "L" bracket (070742) onto the heat shield as shown using the provided hardware.



12. Install the provided "L" bracket (070066) onto the heat shield as shown using the provided hardware.

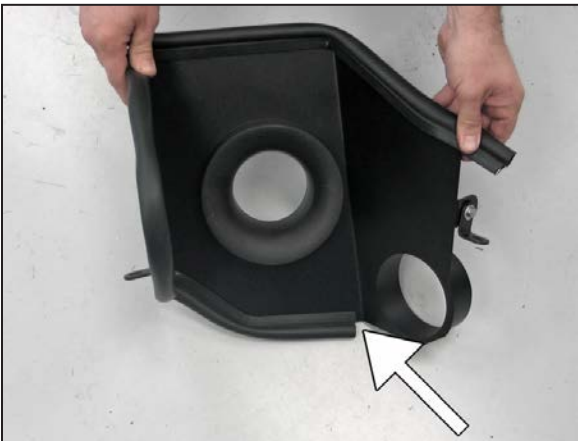

13. Install the provided edge trim onto the heat shield as shown. **NOTE: Some trimming of the edge trim will be necessary.**



14. Install the silicone hump hose (08699) onto the filter adapter as shown, secure with the provided hose clamp.



15. Set the heat shield assembly into the engine compartment so the silicone hose slips onto the intake tube and the fresh air duct slips over the tube attached to the heat shield. Align the intake tube and hoses, then tighten the hose clamps and secure the heat shield brackets to the airbox mounting locations using the provided hardware.



16. Install the 1/2"ID silicone vent hose onto the valve cover port. Connect the opposite end of the vent hose to the 1/2"OD vent fitting installed in the intake tube.

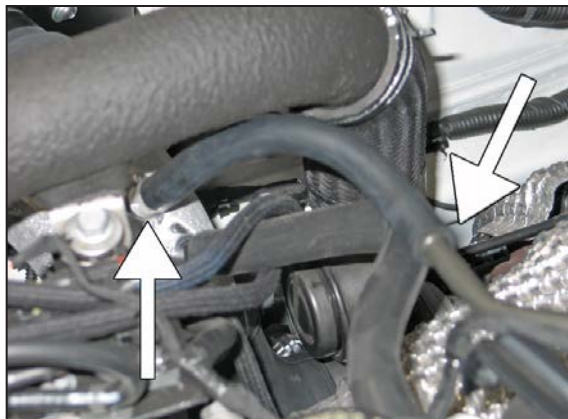

17. Install the 3/8"ID silicone vent hose onto the steel hard line port. Connect the opposite end of the vent hose to the 3/8"OD vent fitting installed in the intake tube.

NOTE: On automatic transmission equipped vehicle, this hose is not used.



18. Install the K&N® air filter and secure with the provided hose clamp. **NOTE: Drycharger® air filter wrap; part # 22-8036PK is available to purchase separately.**



19. Reconnect the vehicle's negative battery cable. Double check to make sure everything is tight and properly positioned before starting the vehicle.

20. It will be necessary for all K&N® high flow intake systems to be checked periodically for realignment, clearance and tightening of all connections. Failure to follow the above instructions or proper maintenance may void warranty.

ROAD TESTING:

1. Start the engine with the transmission in neutral or park, and the parking brake engaged. Listen for air leaks or odd noises. For air leaks secure hoses and connections. For odd noises, find cause and repair before proceeding. This kit will function identically to the factory system except for being louder and much more responsive.
2. Test drive the vehicle. Listen for odd noises or rattles and fix as necessary.
3. If road test is fine, you can now enjoy the added power and performance from your kit.
4. K&N Engineering, Inc., requires cleaning the intake system's air filter element every 100,000 miles. When used in dusty or off-road environments, our filters will require cleaning more often. We recommend that you visually inspect your filter once every 25,000 miles to determine if the screen is still visible. When the screen is no longer visible some place on the filter element, it is time to clean it. To clean and re-oil, purchase our filter Recharger® service kit, part number 99-5050 or 99-5000 and follow the easy instructions.