

# K&N® TYPHOON INTAKE SYSTEMS

## INSTALLATION INSTRUCTIONS

### 69-4533TTK CHEVROLET 2014-15 Camaro Z28 V8-7.0L

#### TOOLS NEEDED:

Flat Blade Screw driver  
ratchet  
Extension  
10mm socket  
10mm wrench  
3mm allen  
4mm allen  
T25 TORX

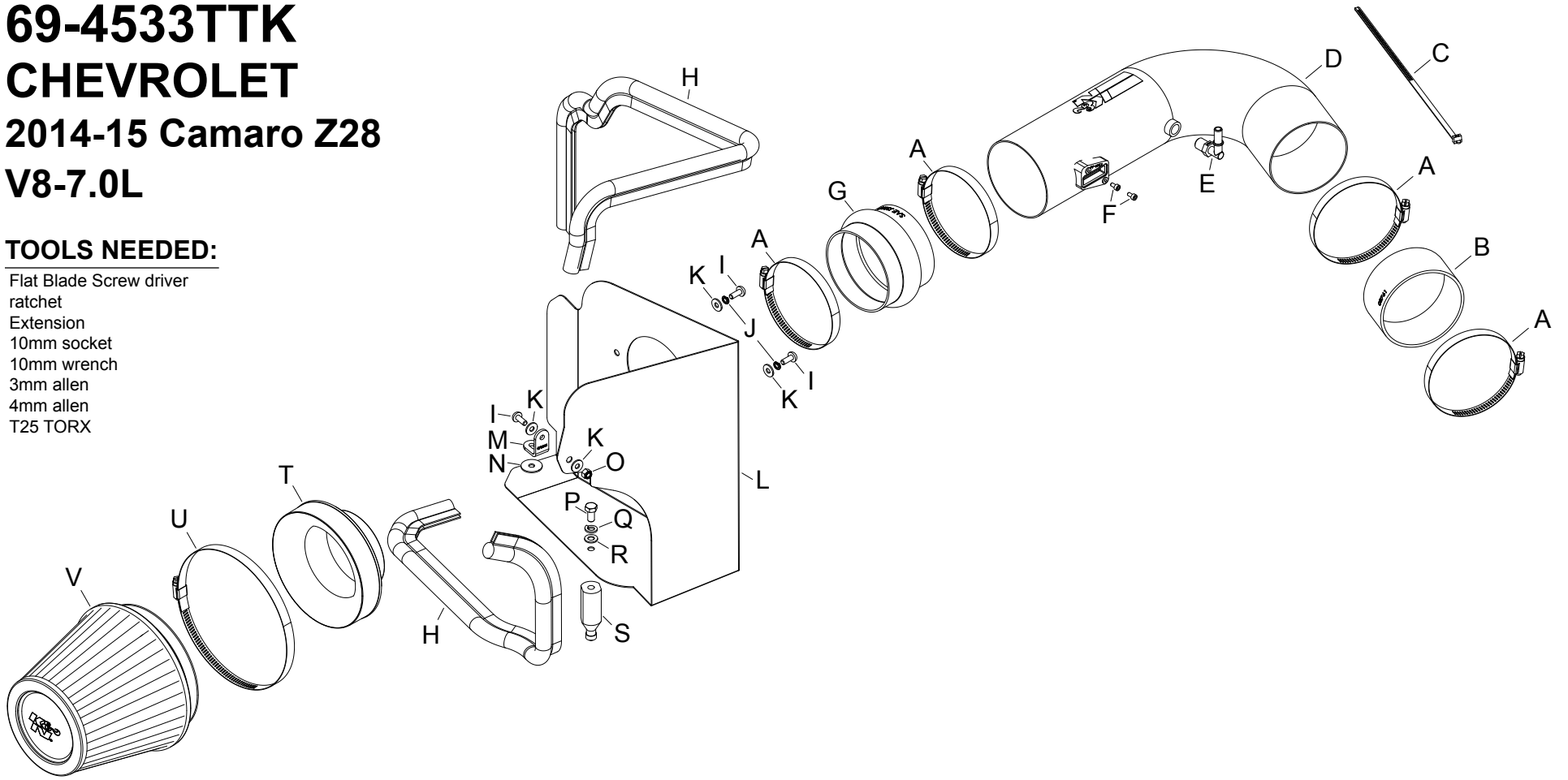

#### PARTS LIST:

| Description                    | Qty. | Part #  | Description                  | Qty. | Part # | Description                  | Qty. | Part #  |
|--------------------------------|------|---------|------------------------------|------|--------|------------------------------|------|---------|
| A HOSE CLAMP #64, BLACK ZINC   | 4    | 08645K  | I BOLT; M6 X 1.00 X 16MM, SS | 3    | 07730  | Q WASHER, M8 SPLIT LOCK ZINC | 1    | 1-3036  |
| B HOSE; 4" ID X 2" L           | 1    | 08761   | J WASHER, M6 SPLIT LOCK ZINC | 2    | 1-3025 | R WASHER; 8MM, FLAT, SS      | 1    | 08272   |
| C CABLE TIES; 11" BLACK        | 1    | 21590   | K WASHER; 6MM FLAT, SS       | 4    | 08269  | S STANDOFF; 6.0 FORD AIRBOX  | 1    | 06532   |
| D INTAKE TUBE                  | 1    | 27659TK | L HEAT SHIELD (CARBON FIBER) | 1    | 073228 | T ADAPTOR; 57-3058 #454      | 1    | 27300   |
| E VENT; 90°, 1/4 NPT TO .375"  | 1    | 82632   | M BRACKET; 69-2521, "L", SML | 1    | 070066 | U HOSE CLAMP #104, BLACK     | 1    | 08697K  |
| F BOLT; M4 - 0.07 8MM, A/H CAP | 2    | 07733   | N WASHER; 1" X .300 X .100   | 1    | 21685  | V AIR FILTER                 | 1    | RP-5168 |
| G HOSE; 4" ID X 3" L HUMP      | 1    | 08418   | O NUT; 6MM NYLOCK, HEXHEAD   | 1    | 07512  |                              |      |         |
| H EDGE TRIM (70")              | 1    | 1024154 | P BOLT; 8MM-1.25 X 16MM, HEX | 1    | 07844  |                              |      |         |

**NOTE: FAILURE TO FOLLOW INSTALLATION INSTRUCTIONS AND NOT USING THE PROVIDED HARDWARE MAY DAMAGE THE INTAKE TUBE, THROTTLE BODY AND ENGINE.**

#### TO START:

1. Turn off the ignition and disconnect the negative battery cable.

**NOTE: Disconnecting the negative battery cable erases pre-programmed electronic memories. Write down all memory settings before disconnecting the negative battery cable. Some radios will require an anti-theft code to be entered after the battery is reconnected. The anti-theft code is typically supplied with your owner's manual. In the event your vehicles anti-theft code cannot be recovered, contact an authorized dealership to obtain your vehicles anti-theft code.**



2. Disconnect the mass air sensor electrical connection and unhook the wiring harness from the intake tube.



3. Release the locking ring and then disconnect the crank case vent from the intake tube.



4. Lift up and remove the driver's side engine cover.



5. Loosen the hose clamps securing the intake tube to the throttle body and mass air sensor then remove the intake tube from the vehicle.



6. Remove the two nuts securing the air filter housing to the inner fender.



7. Lift up the air filter housing to dislodge it from the inner fender and then remove it from the vehicle.  
**NOTE: K&N Engineering, Inc., recommends that customers do not discard factory air intake.**



8. Install the provided air filter adapter into the K&N® heat shield and secure with the provided hardware.

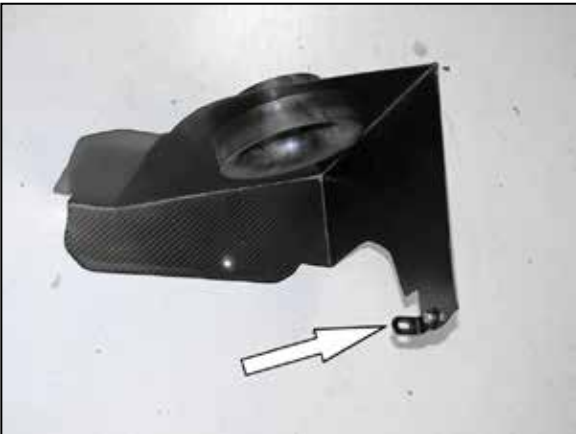

9. Install the heat shield mounting bracket (070066) onto the heat shield using the provided hardware.



10. Install the provided mounting stud onto the heat shield using the provided hardware.

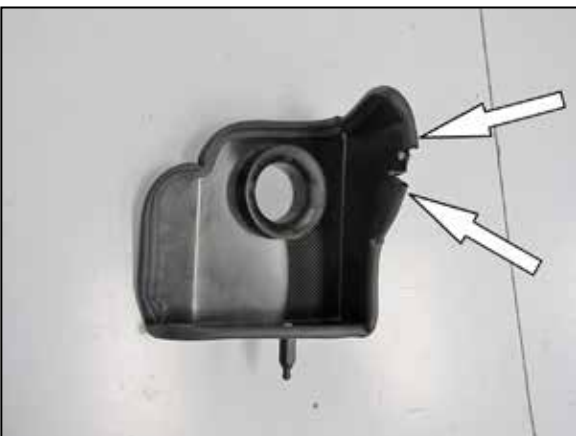

11. Install the provided edge trim onto the heat shield as shown.  
**NOTE: Some trimming of the edge trim will be necessary.**



12. Install the provided rubber washer onto the air filter housing mounting stud as shown.



13. Install the heat shield assembly into the vehicle so that the mounting bracket slides onto the mounting stud and the mounting stud inserts into the factory mounting bracket. Then secure the heat shield with the factory nut and secure the ground strap to the threaded stud with the factory fastener.



14. Install the provided coupler hose #08761 onto the throttle body and secure with the provided hose clamp.



15. Install the provided hump coupler hose #08418 onto the filter adapter and secure with the provided hose clamp.



16. Remove the mass air sensor from the factory housing as shown.



17. Install the mass air sensor into the K&N® intake tube and secure with the provided hardware.



18. Install the 90° NPT quick disconnect npt fitting into the K&N® intake tube as shown.  
**NOTE: Plastic NPT fittings are easy to cross thread. Install the vent fitting "hand" tight, then turn it two complete turns with a wrench.**



19. Install the intake tube into the Hump hose and then into the hose at the throttle body, adjust the tube for best fit and then secure with the provided hose clamps.



20. Connect the stock ccv hose the quick disconnect fitting installed into the intake tube.



21. Connect the mass air sensor electrical connection and then secure the wiring harness to the engine harness with the provided tie wrap.



22. Reinstall the driver's side engine cover.



23. Install the K&N® air filter and secure with the provided hose clamp.



24. Reconnect the vehicle's negative battery cable. Double check to make sure everything is tight and properly positioned before starting the vehicle.

25. It will be necessary for all K&N® high flow intake systems to be checked periodically for realignment, clearance and tightening of all connections. Failure to follow the above instructions or proper maintenance may void warranty.

**ROAD TESTING:**

1. Start the engine with the transmission in neutral or park, and the parking brake engaged. Listen for air leaks or odd noises. For air leaks secure hoses and connections. For odd noises, find cause and repair before proceeding. This kit will function identically to the factory system except for being louder and much more responsive.

2. Test drive the vehicle. Listen for odd noises or rattles and fix as necessary.

3. If road test is fine, you can now enjoy the added power and performance from your kit.

4. K&N Engineering, Inc., requires cleaning the intake system's air filter element every 100,000 miles. When used in dusty or off-road environments, our filters will require cleaning more often. We recommend that you visually inspect your filter once every 25,000 miles to determine if the screen is still visible. When the screen is no longer visible some place on the filter element, it is time to clean it. To clean and re-oil, purchase our filter Recharger® service kit, part number 99-5050 or 99-5000 and follow the easy instructions.