

# K&N TYPHOON INTAKE SYSTEMS

## INSTALLATION INSTRUCTIONS

### 69-4526TS CHEVROLET 2013-14 Impala V6-3.6L

#### TOOLS NEEDED:

Ratchet  
Extension  
13mm Socket  
10mm Socket  
T20 torx  
Flat Sided Screw Driver  
Pliers  
5/8" Wrench  
4mm Allen Key  
3mm Allen Key  
5/8" Wrench  
10mm Wrench  
Pliers

#### PARTS LIST:

Description	Qty.	Part #	Description	Qty.	Part #	Description	Qty.	Part #
A HOSE CLAMP #44 STAINLESS	2	08560	I HOSE; 3.5"ID TO 3.25"ID	1	08496	Q NUT; 6MM NYLOCK, HEXHEAD	1	07512
B HOSE; 3" ID X 3"L HUMP	1	08696	J ADAPTOR; 1-1/8" OD QUICK	1	088012	R BRACKET; 57-2505, "L", FIN	1	07093
C INTAKE TUBE	1	27343TS	K SUPER GLUE, 3G DRIP PROOF	1	409	S HEAT SHIELD	1	073142
D VENT; STRT, 1/4" NPT	1	08938	L HOSE CLAMP #56	1	08620	T BOLT; 6MM-1.00 X 16MM, SS	1	07812
E BOLT; M4 X .7 X 8MM	2	07741	M EDGE TRIM; 3/4 BULB, TOP	1	102471	U ADAPTER; UNIVERSAL, 6"	1	21512-1
F HOSE; 1"ID X 11"L W/1" L 90	1	08479	N NBOLT; M6 X 1.00 X 16MM	2	07730	V HOSE CLAMP # 104	1	08697
G VENTURI; 3.075"OD x 2.975	1	9-0378	O WAHER; M6 SPLIT LOCK ZINC	2	1-3025	W AIR FILTER	1	RF-1048
H HOSE CLAMP #48	1	08601	P WASHER; 6MM FLAT, SS	4	08269	X CAP	1	08246
						Y CLAMP	1	08413

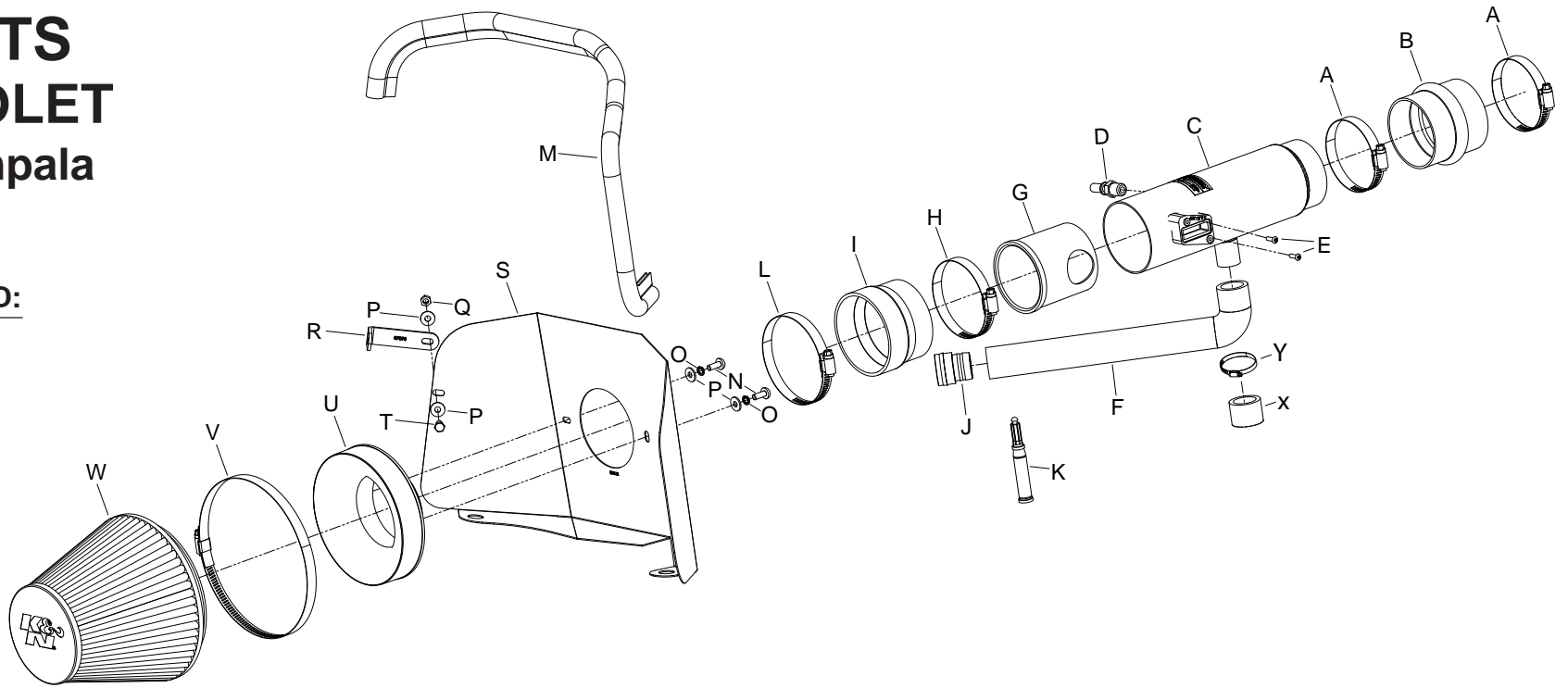

**NOTE: FAILURE TO FOLLOW INSTALLATION INSTRUCTIONS AND NOT USING THE PROVIDED HARDWARE MAY DAMAGE THE INTAKE TUBE, THROTTLE BODY AND ENGINE.**

#### TO START:

1. Turn off the ignition and disconnect the negative battery cable.

**NOTE: Disconnecting the negative battery cable erases pre-programmed electronic memories. Write down all memory settings before disconnecting the negative battery cable. Some radios will require an anti-theft code to be entered after the battery is reconnected. The anti-theft code is typically supplied with your owner's manual. In the event your vehicles anti-theft code cannot be recovered, contact an authorized dealership to obtain your vehicles anti-theft code.**



2. Remove the oil fill cap and then remove the engine cover from the engine. Reinstall the oil fill cap.



3. Remove the three bolts securing the body brace and then remove the body brace.

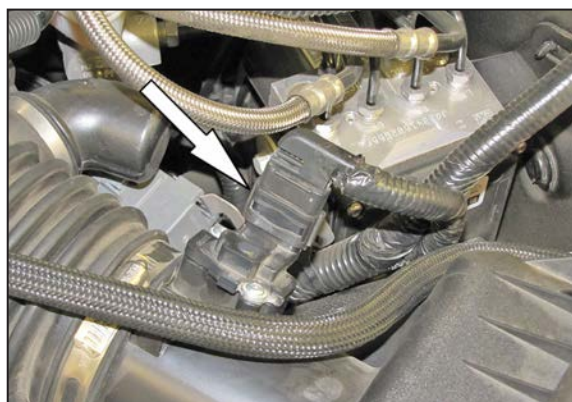

4. Release the red locking tab and then disconnect the mass air sensor electrical connection.



5. Loosen the hose clamp securing the factory intake tube to the throttle body, and then disconnect the crank case vent hose from the intake tube.



6. On vehicles equipped with air injection, disconnect the air injection hose at the quick disconnect fitting as shown.



7. Lift up and remove the complete intake system as shown.

**NOTE: K&N Engineering, Inc., recommends that customers do not discard factory air intake.**



8. Remove two of the factory mounting grommets from the air box.

**NOTE: These grommets will be used in a later step.**



9. Remove the two screws securing the mass air sensor and then remove the sensor from the air box.





10. Apply several drops of the provided glue to the mass air insert as shown.



11. Install the mass air insert into the K&N® intake tube so that the hole in the insert aligns with the mass air location in the tube.



12. Install the mass air sensor and secure with the provided hardware.



13. Install the provided NPT quick disconnect fitting into the K&N® intake tube as shown.  
**NOTE: Plastic NPT fittings are easy to cross thread. Install the vent fitting "hand" tight, then turn it two complete turns with a wrench.**



13a. On vehicles that are not equipped with air injection, install the provided cap onto the fitting and secure with the provided hose clamp.



14. Install the filter adapter into the heat shield and secure with the provided hardware.

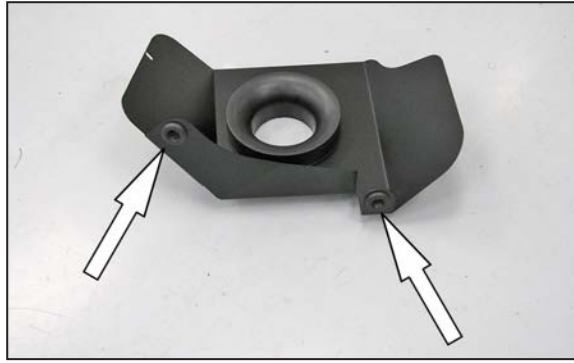

15. Install the air box mounting grommets from step #8 into the two holes of the heat shield.

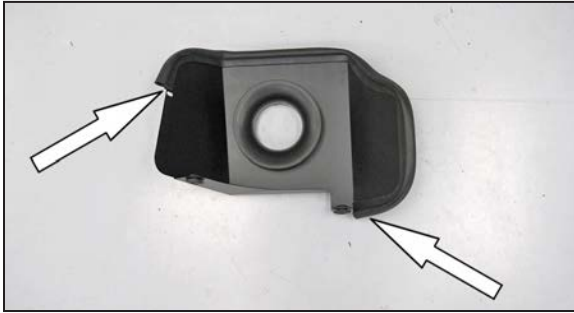

16. Install the provided edge trim onto the heat shield as shown.  
**NOTE: Some trimming of the edge trim will be necessary.**



17. Install the air filter onto the filter adapter and secure with the provided hose clamp.  
**NOTE: Drycharger® air filter wrap; part # RF-1048DK is available to purchase separately.**



18. Install the provided hump hose (08696) onto the throttle body and secure with the provided hose clamp.

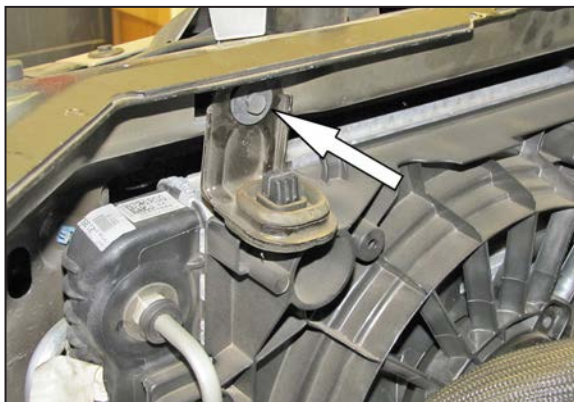

19. Remove the bolt shown that secures the radiator mount to the core support.



20. Install the provided "L" bracket (07093) onto the radiator mount and secure with the factory bolt removed in step #19.

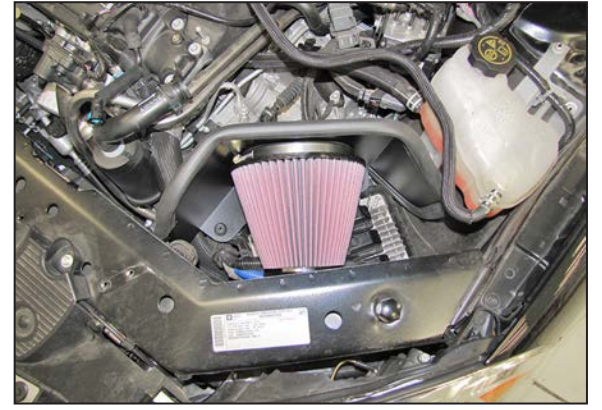

21. Install the heat shield assembly into the vehicle so the mounting grommets set onto the mounting studs.

**NOTE: Do not secure the heat shield to the bracket at this time.**



22. Install the provided hose (08496) onto the intake tube as far as it will slide on, do not tighten at this time.



23. Install the K&N® intake tube into the hose at the throttle body and align the tube with the filter adapter. Slide the hose into position and secure with the provided hose clamps.



24. Secure the heat shield to the mounting bracket with the hardware provided.



25. On vehicles equipped with air injection, cut the provided air injection hose to a length if 7-1/2" long as shown.



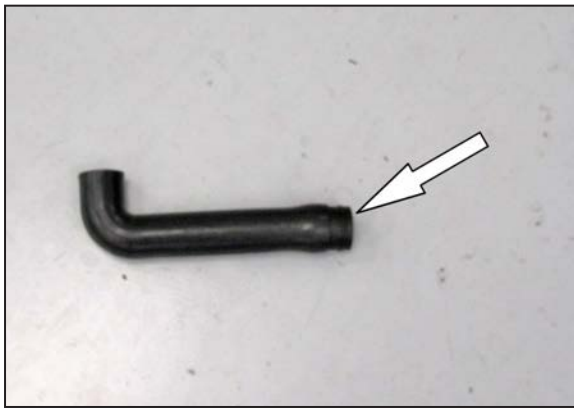

26. On vehicles equipped with air injection, install the provided quick disconnect fitting in to the straight end of the provided hose.

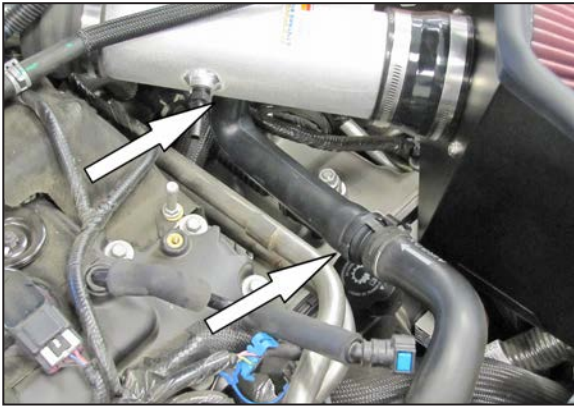

27. On vehicles equipped with air injection, install the air injection hose onto the K&N® intake tube and then connect it with the factory air injection tube.



28. Connect the factory crank case vent hose to the fitting installed into the K&N® intake tube as show.



29. Reconnect the Mass air sensor electrical connection.

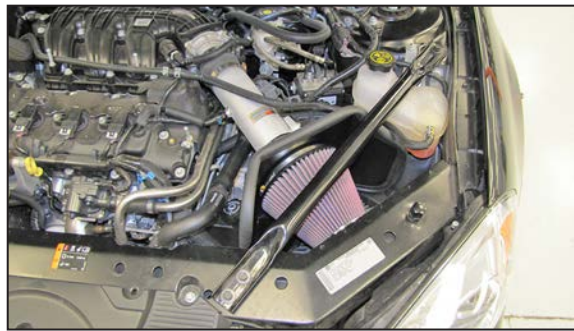

30. Reinstall the body brace and secure with the factory hardware.



31. Reinstall the engine cover.



32. Reconnect the vehicle's negative battery cable. Double check to make sure everything is tight and properly positioned before starting the vehicle.

33. It will be necessary for all K&N® high flow intake systems to be checked periodically for realignment, clearance and tightening of all connections. Failure to follow the above instructions or proper maintenance may void warranty.

#### ROAD TESTING:

1. Start the engine with the transmission in neutral or park, and the parking brake engaged. Listen for air leaks or odd noises. For air leaks secure hoses and connections. For odd noises, find cause and repair before proceeding. This kit will function identically to the factory system except for being louder and much more responsive.

2. Test drive the vehicle. Listen for odd noises or rattles and fix as necessary.

3. If road test is fine, you can now enjoy the added power and performance from your kit.

4. K&N Engineering, Inc., requires cleaning the intake system's air filter element every 100,000 miles. When used in dusty or off-road environments, our filters will require cleaning more often. We recommend that you visually inspect your filter once every 25,000 miles to determine if the screen is still visible. When the screen is no longer visible some place on the filter element, it is time to clean it. To clean and re-oil, purchase our filter Recharger® service kit, part number 99-5050 or 99-5000 and follow the easy instructions.