

K&N TYPHOON INTAKE SYSTEMS

INSTALLATION INSTRUCTIONS

69-4525TS CHEVROLET 2012-17 Sonic L4-1.8L

TOOLS NEEDED:

Ratchet
Extension
15mm Socket
10mm Socket
10mm Wrench
2.5mm Allen Wrench
T20 torx socket
Flat Blade Screw Driver

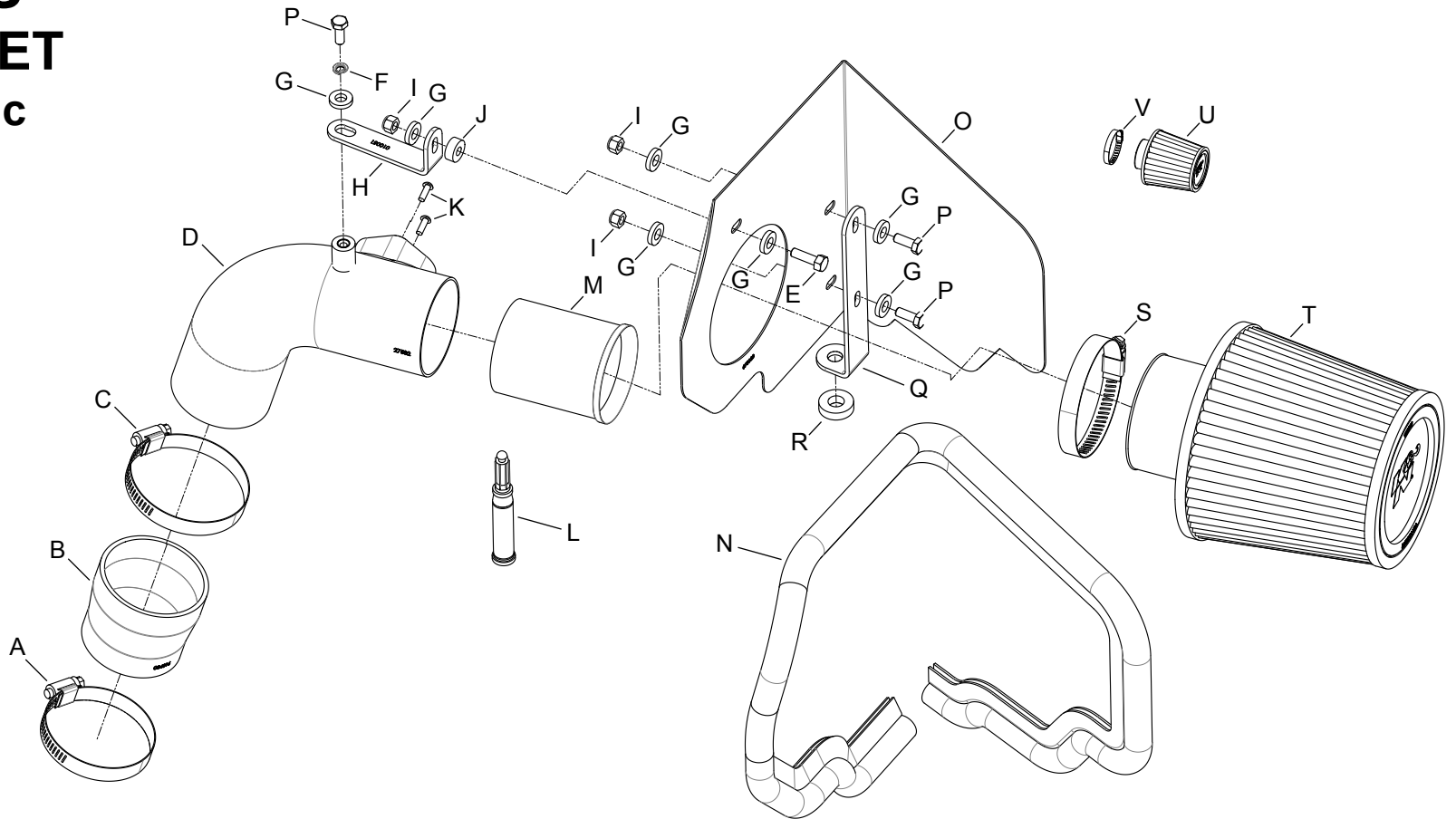

PARTS LIST:

| Description | Qty. | Part # | Description | Qty. | Part # | Description | Qty. | Part # |
|--------------------------------|------|---------|------------------------------|------|--------|------------------------------|------|-----------|
| A HOSE CLAMP #40 | 1 | 08554 | H BRACKET; "L" 69-3510, STL | 1 | 010051 | O HEAT SHIELD | 1 | 073123 |
| B HOSE; 2-3/4" TO 2-1/2"ID | 1 | 084016 | I NUT; 6MM NYLOCK, HEXHEAD | 3 | 07512 | P BOLT; 6MM-1.00 X 16MM, SS | 3 | 07812 |
| C HOSE CLAMP #44 STAINLESS | 1 | 08560 | J SPACER; .625" OD X .250"ID | 1 | 06555 | Q BRACKET; L, 69-4524, STL | 1 | 083172 |
| D INTAKE TUBE | 1 | 27582TS | K SCREW; M4-.7 X 12, SS | 2 | 07726 | R SPACER; 0.937"OD X .437"ID | 1 | 21715 |
| E BOLT; M6 X 1.00" X 20MM HEX | 1 | 07795 | L SUPER GLUE, 3G DRIP PROOF | 1 | 409 | S HOSE CLAMP #44 | 1 | 08577 |
| F WASHER; M6 SPLIT LOCK ZINC | 1 | 1-3025 | M VENTURI; 2.59"OD X 2.37"ID | 1 | 9-0381 | T AIR FILTER | 1 | RU-4960XD |
| G WASHER; 1/4"ID X 5/8"OD -SAE | 7 | 08275 | N EDGE TRIM (44") | 1 | 102486 | U BREATHER FILTER | 1 | RC-2540 |
| | | | | | | V HOSE CLAMP #20 | 1 | 08431 |

NOTE: FAILURE TO FOLLOW INSTALLATION INSTRUCTIONS AND NOT USING THE PROVIDED HARDWARE MAY DAMAGE THE INTAKE TUBE, THROTTLE BODY AND ENGINE.

TO START:

1. Turn off the ignition and disconnect the negative battery cable.

NOTE: Disconnecting the negative battery cable erases pre-programmed electronic memories. Write down all memory settings before disconnecting the negative battery cable. Some radios will require an anti-theft code to be entered after the battery is reconnected. The anti-theft code is typically supplied with your owner's manual. In the event your vehicles' anti-theft code cannot be recovered, contact an authorized dealership to obtain your vehicles anti-theft code.



2. Disconnect the mass air sensor electrical connection.



3. Loosen the hose clamp securing the intake hose to the air box and then disconnect the intake hose from the air box.



3a. On vehicles that are equipped with air injection, disconnect the air injection hose from the air pump. **NOTE: to unlock the air injection fitting, squeeze the outer locking ring to disengage the locking tabs.**



4. Lift up and remove the air box from the vehicle as shown.

NOTE: The air box is held in with three rubber grommets
NOTE: K&N Engineering, Inc., recommends that customers do not discard factory air intake.



5. Loosen the hose clamp securing the intake hose to the throttle body and then remove the intake tube from the engine.



6. Install the silicone hose (084016) onto the throttle body and secure with the provided hose clamp.



7. Install the heat shield mounting bracket #(083172) onto the heat shield as shown using the provided hardware.



8. Install the provided edge trim onto the heat shield as shown.
NOTE: Some trimming of the edge trim will be necessary.



9. Apply several drops of the provided "Super Glue" to the lip of the venturi as shown.



10. Install the venturi into the K&N® intake tube so that the hole lines up with the mass air sensor adapter.
NOTE: Some tapping may be needed to fully seat the venturi into the intake tube.



11. Remove the two screws securing the mass air sensor into the factory air box and then remove the mass air sensor from the air.



12. Install the mass air sensor into the K&N® intake tube and secure with the provided hardware.



13. Remove the rear engine mounting bolt shown.
NOTE: This bolt will be reused.



14. Install the K&N® intake tube into the silicone hose but do not completely tighten at this time.



15. Set the Heat shield assembly along with the provided spacer onto the engine mount and secure with the engine mounting bolt removed in step #13.



16. Install the tube mounting bracket (010051) onto the heat shield along with the provided spacer. Align the tube and heat shield for proper fit and then secure the bracket, heat shield and intake tube with the provided hardware.



17. Install the K&N® air filter onto the intake tube and secure with the provided hose clamp.
NOTE: Drycharger® air filter wrap; part # RX-4990DK is available to purchase separately.



18. Reconnect the mass air sensor electrical connection.



18a. On vehicles equipped with air injection, release the clamp securing the factory air injection fitting to the hose and then remove the fitting from the hose.



18b. On vehicles equipped with air injection, install the provided breather filter onto the factory fitting from step #11a as shown and secure with the provided hose clamp.

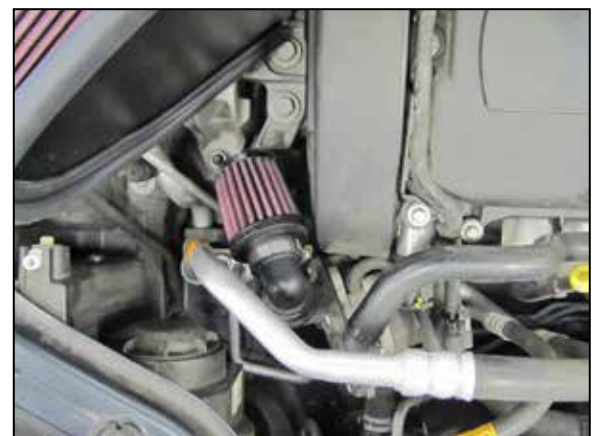

18c. On vehicles equipped with air injection, install the breather assembly onto the air injection pump as shown.



19. Reconnect the vehicle's negative battery cable. Double check to make sure everything is tight and properly positioned before starting the vehicle.

20. It will be necessary for all K&N® high flow intake systems to be checked periodically for realignment, clearance and tightening of all connections. Failure to follow the above instructions or proper maintenance may void warranty.

ROAD TESTING:

1. Start the engine with the transmission in neutral or park, and the parking brake engaged. Listen for air leaks or odd noises. For air leaks secure hoses and connections. For odd noises, find cause and repair before proceeding. This kit will function identically to the factory system except for being louder and much more responsive.

2. Test drive the vehicle. Listen for odd noises or rattles and fix as necessary.

3. If road test is fine, you can now enjoy the added power and performance from your kit.

4. K&N Engineering, Inc., requires cleaning the intake system's air filter element every 100,000 miles. When used in dusty or off-road environments, our filters will require cleaning more often. We recommend that you visually inspect your filter once every 25,000 miles to determine if the screen is still visible. When the screen is no longer visible some place on the filter element, it is time to clean it. To clean and re-oil, purchase our filter Recharger® service kit, part number 99-5050 or 99-5000 and follow the easy instructions.