

K&N TYPHOON INTAKE SYSTEMS

INSTALLATION INSTRUCTIONS

69-4524TS CHEVROLET 2012-17 Sonic L4-1.4L Turbo

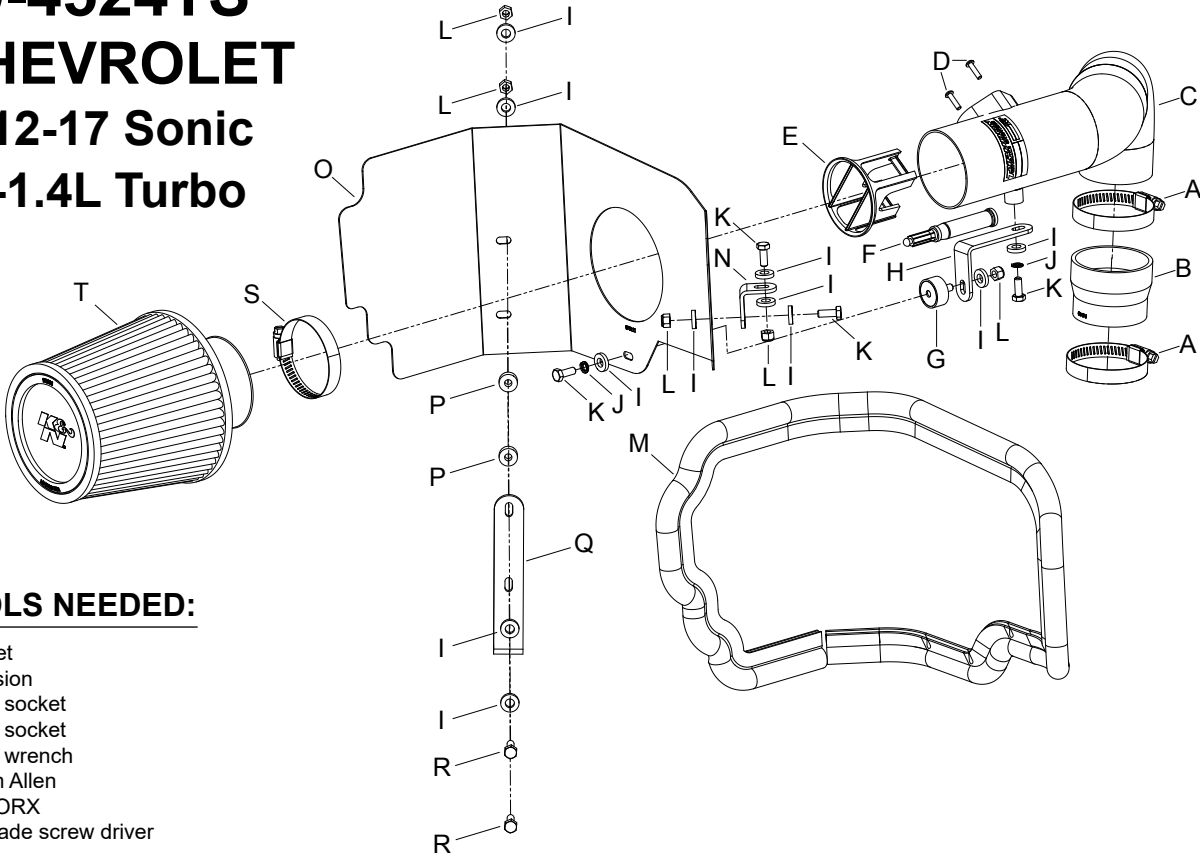

TOOLS NEEDED:

Ratchet
Extension
15mm socket
10mm socket
10mm wrench
2.5mm Allen
T20 TORX
Flat blade screw driver

PARTS LIST:

Description	Qty.	Part #
A Hose Clamp #36	2	08530
B Hose; 2-1/2" TO 2-1/4" ID X 2"L TPRD	1	08476
C Intake Tube	1	27580TS
D Screw; M4-.7 X 16MM, Buttonhead SS	2	07793
E MAF Insert; Air STRTNR, 2.59"OD	1	9-21070
F Super Glue, 3G Drip Proof	1	409
G Stud; Rubber MNT, M/F, 1/2"L X 1"W	1	070228
H Bracket; "L" Small, STL, TB/PC	1	010031
I Washer; 1/4"ID X 5/8"OD- SAE	11	08275
J Washer; M6 Split Lock Zinc	2	1-3025
K Bolt; 6MM -1.00 X 16MM, SS	4	07812
L Nut; 6MM Nylock, Hexhead, SS	5	07512
M Edge Trim (48")	1	102485
N Bracket; 69-2521, "L", SML, STL	1	070066
O Heat Shield	1	073121
P Spacer; .625" OD X .250"ID X 250"L	2	06555
Q Bracket; L, 69-4524, STL, TB/PC	1	083172
R Bolt; M6 X 1.00" X 20MM Hex, SS	2	07795
S Hose Clamp #44	1	08577
T Air Filter	1	RU-4960XD

NOTE: FAILURE TO FOLLOW INSTALLATION INSTRUCTIONS AND NOT USING THE PROVIDED HARDWARE MAY DAMAGE THE INTAKE TUBE, THROTTLE BODY AND ENGINE.

TO START:

1. Turn off the ignition and disconnect the negative battery cable.

NOTE: Disconnecting the negative battery cable erases pre-programmed electronic memories. Write down all memory settings before disconnecting the negative battery cable. Some radios will require an anti-theft code to be entered after the battery is reconnected. The anti-theft code is typically supplied with your owner's manual. In the event your vehicles' anti-theft code cannot be recovered, contact an authorized dealership to obtain your vehicles anti-theft code.



2. Disconnect the mass air sensor electrical connection.



3. Loosen the hose clamp securing the intake tube to the turbo inlet.



4. Disconnect the intake tube from turbo inlet, and then lift up the air box to dislodge it from the mounting grommets and then remove the air box assembly from the vehicle.

NOTE: K&N Engineering, Inc., recommends that customers do not discard factory air intake.



5. Remove the rear engine mount bolt shown. **NOTE: This bolt will be reused.**

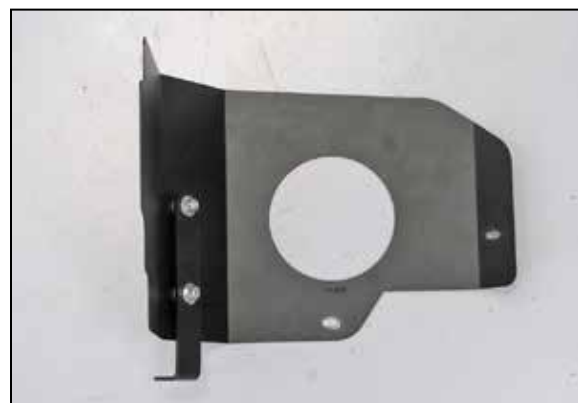

6. Install the heat shield mounting bracket (083172) onto the heat shield as shown with the provided hardware and spacers.



7. Install the provided edge trim onto the heat shield as shown.

NOTE: Some trimming of the edge trim will be necessary.



8. Install the heat shield assembly onto the engine mount and secure with the bolt removed in step #5.

NOTE: Do not completely tighten at this time.



9. Install the provided "L" bracket (070066) onto the core support and heat shield as shown using the provided hardware, then tighten all of the heat shield mounting hardware.

NOTE: The slotted end of the bracket will attach to the core support.



10. Install the provided silicone hose (08476) onto the turbo inlet and secure with the provided hose clamp.



11. Apply several drops of the provided "Super Glue" onto the air guide as shown.



12. Install the air guide into the K&N® intake tube as shown.

NOTE: The main grid planes should be horizontal in the tube when the mass air sensor mount is pointed straight up as in picture.



13. Remove the two screws securing the mass air sensor and then remove the mass air sensor from the air box.



14. Install the mass air sensor into the K&N® intake tube and secure with the provided hardware.



15. Install the rubber mounted stud onto the mounting bracket (010031) and secure with the provided hardware.



16. Install the tube mounting bracket onto the K&N® intake tube as shown using the provided hardware.



17. Install the tube assembly into the silicone hose on the turbo inlet and align so the rubber mounted stud protrudes through the heat shield. Secure the tube with hose clamp and hardware provided.



18. Install the K&N® air filter and secure with the provided hose clamp.

NOTE: Drycharger® air filter wrap; part # RX-4990DK is available to purchase separately.



19. Reconnect the mass air sensor electrical connection.



20. Reconnect the vehicle's negative battery cable. Double check to make sure everything is tight and properly positioned before starting the vehicle.

21. It will be necessary for all K&N® high flow intake systems to be checked periodically for realignment, clearance and tightening of all connections. Failure to follow the above instructions or proper maintenance may void warranty.

ROAD TESTING:

1. Start the engine with the transmission in neutral or park, and the parking brake engaged. Listen for air leaks or odd noises. For air leaks secure hoses and connections. For odd noises, find cause and repair before proceeding. This kit will function identically to the factory system except for being louder and much more responsive.

2. Test drive the vehicle. Listen for odd noises or rattles and fix as necessary.

3. If road test is fine, you can now enjoy the added power and performance from your kit.

4. K&N Engineering, Inc., requires cleaning the intake system's air filter element every 100,000 miles. When used in dusty or off-road environments, our filters will require cleaning more often. We recommend that you visually inspect your filter once every 25,000 miles to determine if the screen is still visible. When the screen is no longer visible some place on the filter element, it is time to clean it. To clean and re-oil, purchase our filter Recharger® service kit, part number 99-5050 or 99-5000 and follow the easy instructions.