



# TYPHOON INTAKE SYSTEMS

## INSTALLATION INSTRUCTIONS

**69-3525TS**

**FORD**

**2010 Mustang**

**V6-4.0L**

**TOOLS NEEDED:**

- Ratchet
- Extension
- 10mm Socket
- T20 Torx
- Flat Blade Screwdriver
- 10mm Wrench
- 5mm Allen
- 4mm Allen
- 2.5mm Allen

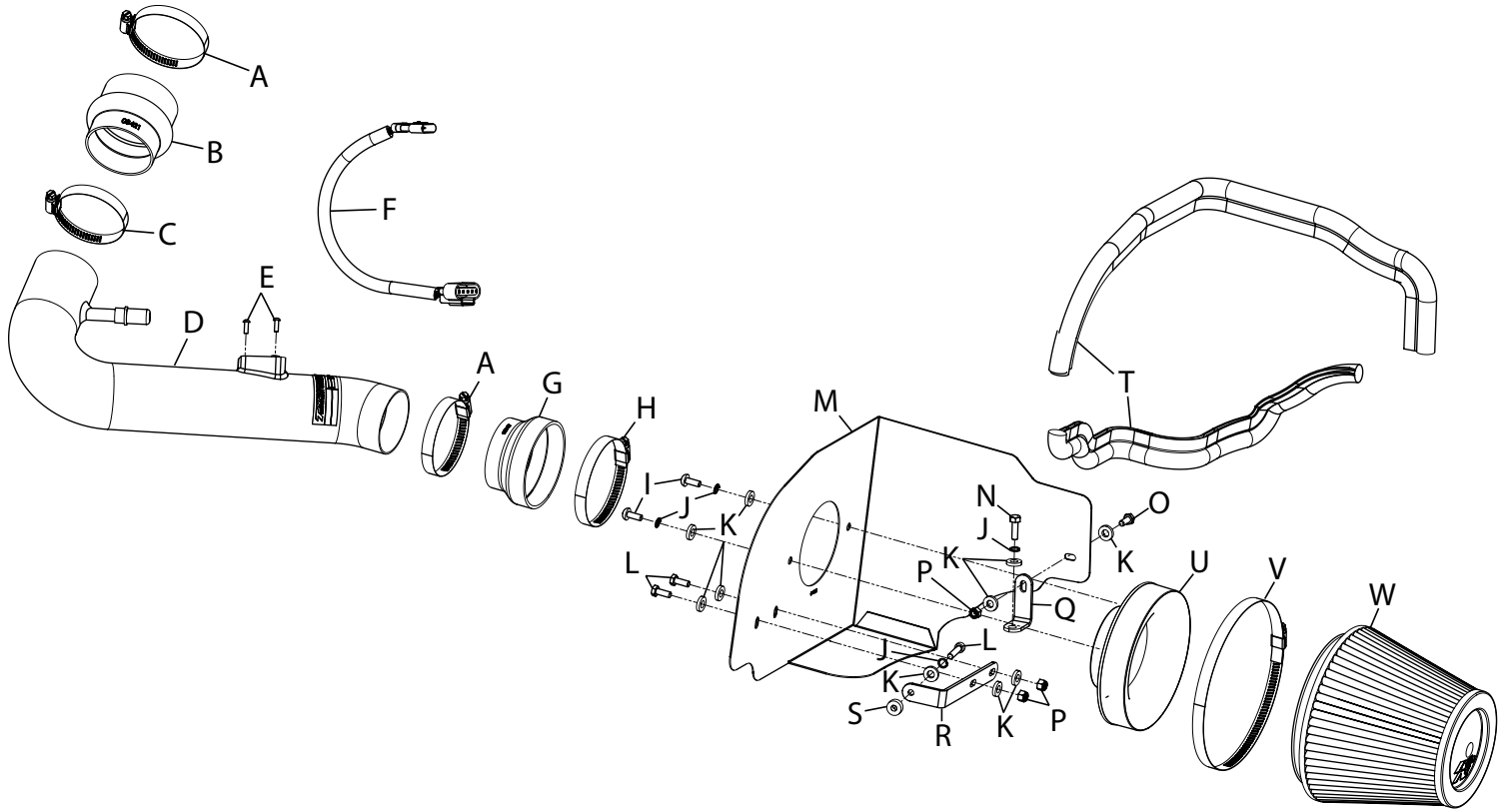

**PARTS LIST:**

Description	Qty.	Part #	Description	Qty.	Part #	Description	Qty.	Part #
A Hose Clamp #44 Stainless	2	08560	I Bolt; M6 X 1.00 X 16MM, Bttnhd, SS	2	07730	Q Bracket; L-Bend, FIN	1	070812
B Hose; 3" TO 2-3/4" X 3" L Hump	1	08421	J Washer; 1/4" Lock, ZN	4	08198	R Bracket; "L", STL, TK/PC	1	083129
C Hose Clamp #40	1	08554	K Washer; 1/4"ID X 5/8"OD - SAE	10	08275	S Spacer: .625" ODx.250"IDx.250"L	1	06555
D Intake Tube	1	27464	L Bolt; 6MM-1.00 X 16MM, SS	3	07812	T Edge Trim (48")	1	102485
E Screw; M4- .7 X 12, Bttnhd SS	2	07726	M Heat Shield	1	074055	U Adapter; Coupler	1	21512-1
F MAF Extension Harness	1	21780	N Bolt; M6 X 1.00" X 20MM HEX, SS	1	07795	V Hose Clamp #104	1	08697
G Hose; 3-1/2" TO 2-3/4"IDx2"L TPRD	1	084093	O Bolt, Socket M6-1 X 30MM	1	1-2020	W Air Filter	1	RC-4381
H Hose Clamp #52	1	08610	P Nut; 6MM Nylcok, Hexhead, SS	3	07512			

**NOTE: FAILURE TO FOLLOW INSTALLATION INSTRUCTIONS AND NOT USING THE PROVIDED HARDWARE MAY DAMAGE THE INTAKE TUBE, THROTTLE BODY AND ENGINE.**

**TO START:**

1. Turn off the ignition and disconnect the negative battery cable.

**NOTE: Disconnecting the negative battery cable erases pre-programmed electronic memories. Write down all memory settings before disconnecting the negative battery cable. Some radios will require an anti-theft code to be entered after the battery is reconnected. The anti-theft code is typically supplied with your owner's manual. In the event your vehicles' anti-theft code cannot be recovered, contact an authorized dealership to obtain your vehicles anti-theft code.**



2. Release the red locking tab and then disconnect the mass air sensor electrical connection.



3. Release the locking ring and then disconnect the crank case vent tube.



4. Loosen the hose clamp which secures the stock intake tube to the throttle body.



5. Remove the bolt which secures air box to the inner fender.



6. Remove the air box assembly from the vehicle. **NOTE: K&N Engineering, Inc., recommends that customers do not discard factory air intake.**

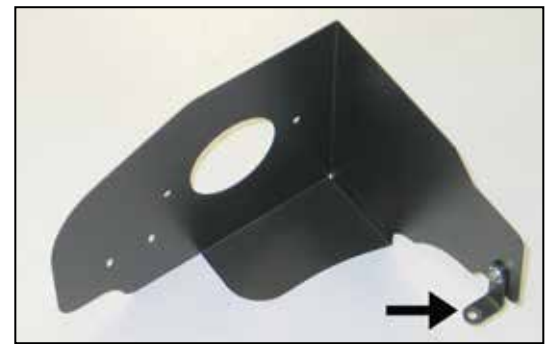

7. Install the small bracket (070812) onto the heat shield as shown and secure with the provided hardware.



8. Install the large bracket (083129) onto the heat shield as shown and secure with the provided hardware.

**NOTE: Do not completely tighten at this time.**

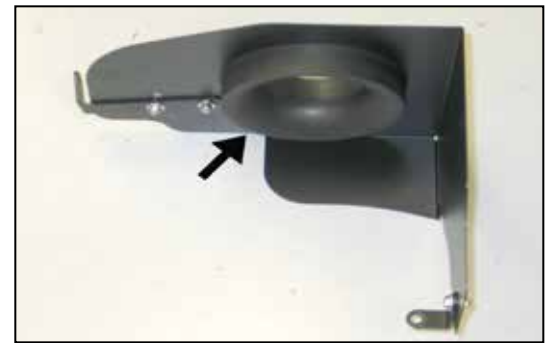

9. Secure the K&N® filter adapter to the heat shield as shown using the provided hardware.

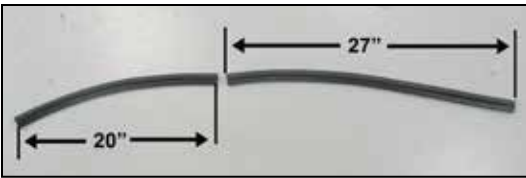

10. Cut the provided edge trim into two sections. The short section should be 20" long; the larger section should be 27" long.



11. Install the longer 27" section of edge trim onto the heat shield as shown.



12. Install the shorter 20" section of edge trim onto the heat shield as shown.



13. Remove the Left upper fan shroud mounting bolt shown.



14. Set the heat shield into position on the inner fender and then secure to the inner fender and fan shroud with the hardware provided.



15. Install the provided hump hose (08421) onto the throttle body and secure with the provided hose clamp.



16. Install the provided step hose (084093) onto the filter adapter and secure with the provided hose clamp.



17. Remove the two screws which secure the mass air sensor and then remove the mass air sensor from the stock air box.



18. Install the mass air sensor into the K&N intake tube and secure with the provided hardware.



19. Install the K&N intake tube into the silicone hose on the filter adapter and then into the silicone hose at the throttle body. Secure the intake tube with the provided hose clamps.



20. Connect the crank case vent hose to the K&N intake tube as shown.



21. Install the K&N air filter and secure with the provided hose clamp.



22. Install the K&N mass air sensor harness extension into the factory wiring harness and then connect the open end into the mass air sensor.



23. Reconnect the vehicle's negative battery cable. Double check to make sure everything is tight and properly positioned before starting the vehicle.

24. The C.A.R.B. exemption sticker, (attached), must be visible under the hood so that an emissions inspector can see it when the vehicle is required to be tested for emissions. California requires testing every two years, other states may vary.

25. It will be necessary for all K&N high flow intake systems to be checked periodically for realignment, clearance and tightening of all connections. Failure to follow the above instructions or proper maintenance may void warranty.

#### ROAD TESTING:

1. Start the engine with the transmission in neutral or park, and the parking brake engaged. Listen for air leaks or odd noises. For air leaks secure hoses and connections. For odd noises, find cause and repair before proceeding. This kit will function identically to the factory system except for being louder and much more responsive.

2. Test drive the vehicle. Listen for odd noises or rattles and fix as necessary.

3. If road test is fine, you can now enjoy the added power and performance from your kit.

4. K&N Engineering, Inc., requires cleaning the intake system's air filter element every 100,000 miles. When used in dusty or off-road environments, our filters will require cleaning more often. We recommend that you visually inspect your filter once every 25,000 miles to determine if the screen is still visible. When the screen is no longer visible some place on the filter element, it is time to clean it. To clean and re-oil, purchase our filter Recharger service kit, part number 99-5050 or 99-5000 and follow the easy instructions.