

K&N TYPHOON INTAKE SYSTEMS

INSTALLATION INSTRUCTIONS

69-3521TP

FORD

2002-04 Mustang GT (except Bullet)

V8-4.6L SOHC

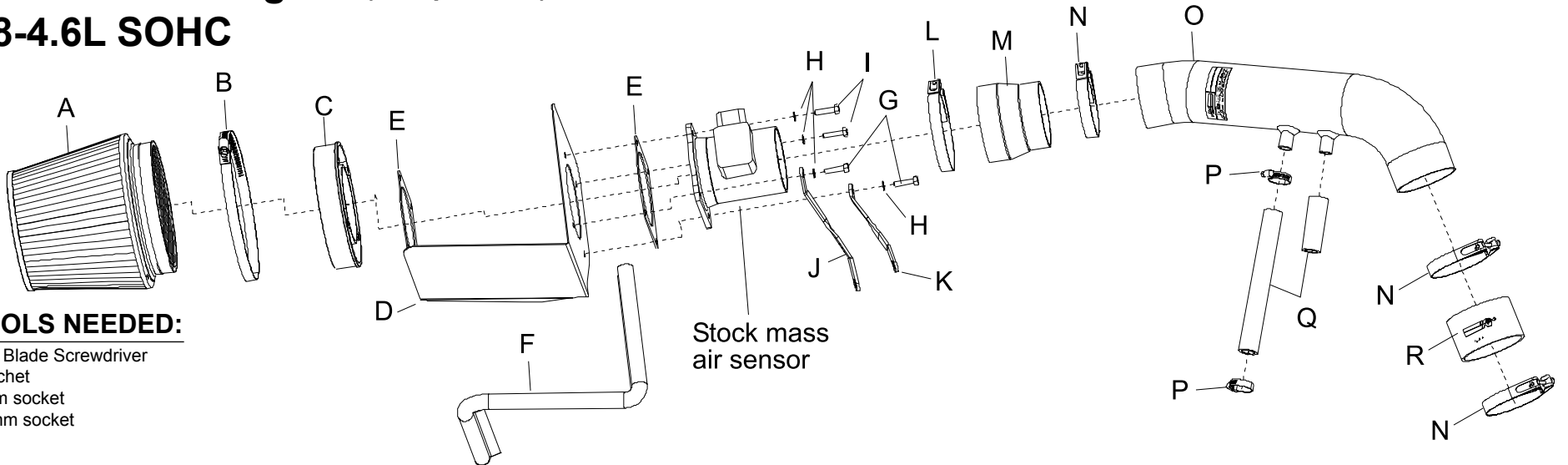

TOOLS NEEDED:

Flat Blade Screwdriver
Ratchet
8mm socket
10mm socket

PARTS LIST:

Description	Qty.	Part #	Description	Qty.	Part #	Description	Qty.	Part #
A AIR FILTER	1	RF-1036	G BOLT; M6 X 1 X 25MM, SS HEX	2	07858	M HOSE; 3"ID X 3-1/2"ID STEP	1	084055
B HOSE CLAMP #104	1	08697	H WASHER; 6MM WAVE, SS	4	08277	N HOSE CLAMP; #44	3	08560
C ADAPTOR; #250	1	08785	I BOLT; M6 X 1 X 20MM, SS HEX	2	07795	O TYPHOON INTAKE TUBE	1	27328
D HEAT SHIELD; 57-2519	1	07411	J BRACKET; 57-2519 SHORT	1	070762	P HOSE CLAMP; #10	2	08411
E GASKET; 1/16" NEOPRENE	2	09984	K BRACKET; 57-2519 TWIST	1	070752	Q HOSE; 5/8"ID X 9-3/4"L	1	084047
F EDGE TRIM; TOP LOC, 23"L	1	102495	L HOSE CLAMP; #60	1	08628	R HOSE; 3"ID X 1-3/4"L, BLACK	1	08434

NOTE: FAILURE TO FOLLOW INSTALLATION INSTRUCTIONS AND NOT USING THE PROVIDED HARDWARE MAY DAMAGE THE INTAKE TUBE, THROTTLE BODY AND ENGINE.

TO START:

1. Turn off the ignition and disconnect the negative battery cable.
NOTE: Disconnecting the negative battery cable erases pre-programmed electronic memories. Write down all memory settings before disconnecting the negative battery cable. Some radios will require an anti-theft code to be entered after the battery is reconnected. The anti-theft code is typically supplied with your owner's manual. In the event your vehicles' anti-theft code cannot be recovered, contact an authorized dealership to obtain your vehicles anti-theft code.



2. Disconnect the mass air sensor electrical connection.



3. Loosen the hose clamp on the intake tube at the throttle body.



4. Loosen and remove the bolt that retains the air cleaner.



5. Detach the IAC line from the intake tube.

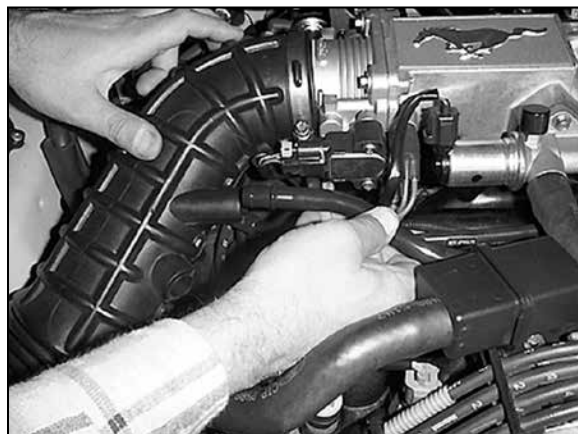

6. Detach the PCV line from the intake tube.



7. Remove the entire air intake assembly.
NOTE: K&N Engineering, Inc., recommends that customers do not discard the factory air intake.

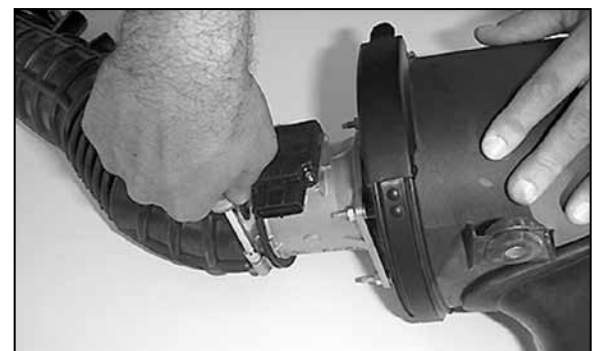

8. Loosen the hose clamp and detach the intake tube from the mass air sensor.



9. Loosen and remove the 4 nuts that retain the mass air sensor.
NOTE: It may be necessary to use a pair of vise grips to hold the studs while loosening the nuts.

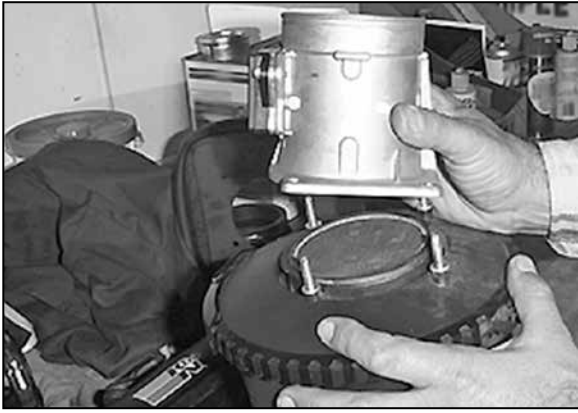

10. Remove the mass air sensor from the air cleaner.

NOTE: The screen will not be reused.



11. Loosen and remove the nut from the protruding stud on the engine.

NOTE: Not all vehicles are equipped with a nut.



12. Install the trim seal onto the heat shield.

NOTE: Some cutting and trimming will be necessary to achieve best fit.



13. Assemble the mass air sensor, heat shield and adapter, using the gaskets and hardware provided as shown, but do not tighten completely at this time.

NOTE: Do not install the hex bolts on the opposite side of flange. See next step.

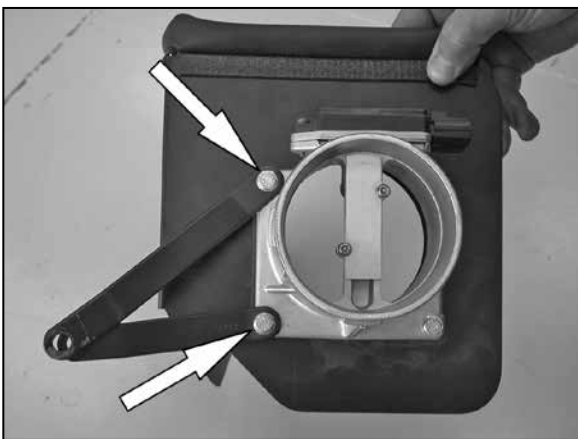

14. Attach the brackets to the mass air sensor flange as shown.

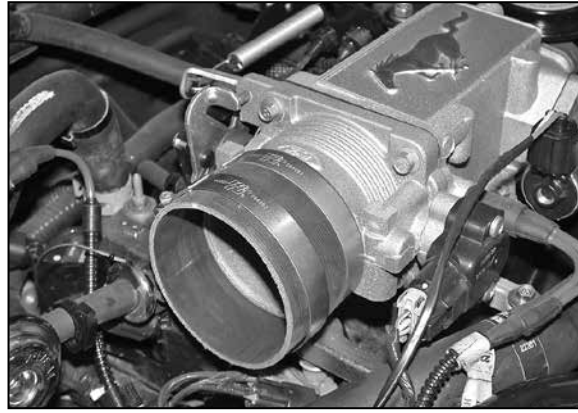

15. Install the provided silicone hose and hose clamps onto the throttle body as shown.



16. Mark and cut 2-1/2" from the provided silicone hose as shown.

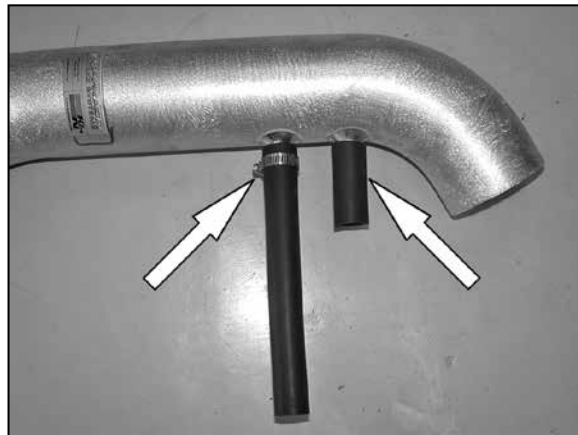

17. Install the provided hoses from the previous step onto the K&N® intake tube and secure with the provided hose clamps.

NOTE: Before installing the silicone hoses, inspect the inside of the tube for any debris, then clean the inside out with water and a towel. Inspect the tube one more time before proceeding to the next step.

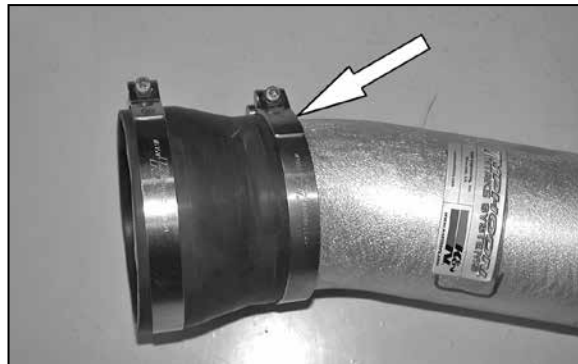

18. Install the provided silicone step hose and hose clamps onto the K&N® intake tube as shown.

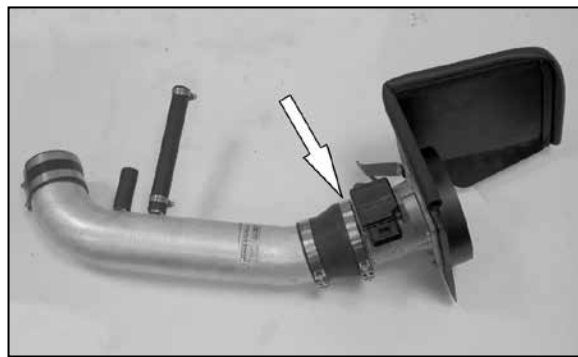

19. Install the K&N® intake tube onto the mass air sensor and snug the hose clamps, but do not tighten completely at this time.

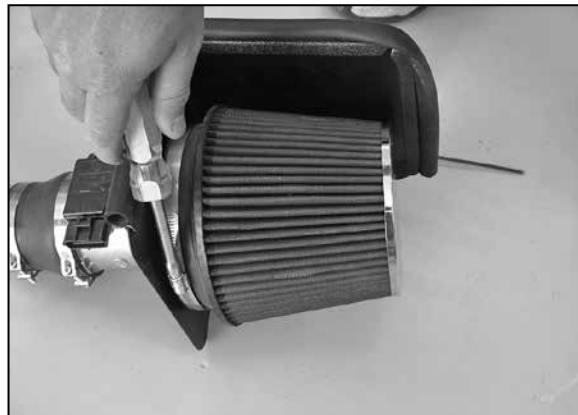

20. Install the K&N® air filter onto the filter adapter and secure with the provided hose clamp as shown.

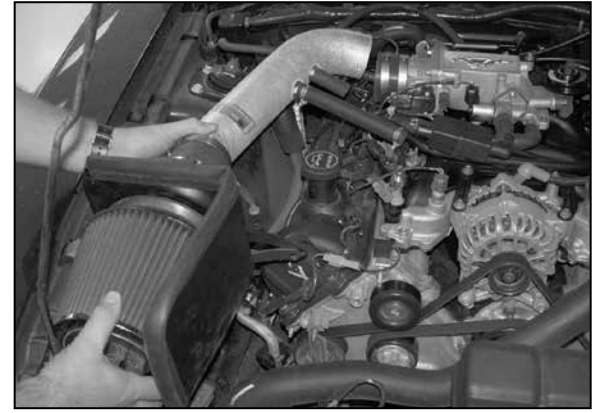

21. Install the complete K&N® intake assembly into the vehicle and slide the tube into the silicone hose on the throttle body as shown.



22. Slide the brackets onto the stud from step 11 and secure with the factory nut.

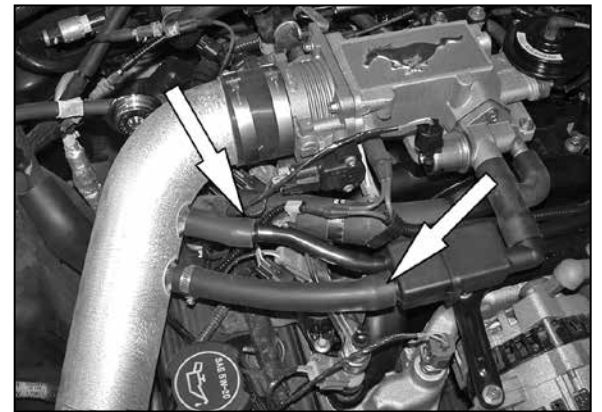

23. Reconnect the vent hoses to the K&N® intake tube as shown and tighten hose clamps.



24. Reconnect mass air sensor electrical connection as shown.



26. Reconnect the vehicle's negative battery cable. Double check to make sure everything is tight and properly positioned before starting the vehicle.

27. The C.A.R.B. exemption sticker, (attached), must be visible under the hood so that an emissions inspector can see it when the vehicle is required to be tested for emissions. California requires testing every two years, other states may vary.

28. It will be necessary for all K&N® high flow intake systems to be checked periodically for realignment, clearance and tightening of all connections. Failure to follow the above instructions or proper maintenance may void warranty.

ROAD TESTING:

1. Start the engine with the transmission in neutral or park, and the parking brake engaged. Listen for air leaks or odd noises. For air leaks secure hoses and connections. For odd noises, find cause and repair before proceeding. This kit will function identically to the factory system except for being louder and much more responsive.

2. Test drive the vehicle. Listen for odd noises or rattles and fix as necessary.

3. If road test is fine, you can now enjoy the added power and performance from your kit.

4. K&N Engineering, Inc., requires cleaning the intake system's air filter element every 100,000 miles. When used in dusty or off-road environments, our filters will require cleaning more often. We recommend that you visually inspect your filter once every 25,000 miles to determine if the screen is still visible. When the screen is no longer visible some place on the filter element, it is time to clean it. To clean and re-oil, purchase our filter Recharger® service kit, part number 99-5050 or 99-5000 and follow the easy instructions.