



# TYPHOON INTAKE SYSTEMS

## INSTALLATION INSTRUCTIONS

69-3513TTK

FORD

2007-09 Focus

L4-2.0L

NOTE: C.A.R.B. E.O. # D-269-37 Excludes LEV2 SULEV 2007-2009 Test Groups: 7FMXV02.0VZP, 8FMXV02.0VZP, 9FMXV02.0VZP, 9FMXV02.0VZX

### TOOLS:

Ratchet  
Extension  
13mm Socket  
10mm Socket  
8mm Socket  
6mm Socket  
Pliers  
13mm Wrench  
Flat Blade Screwdriver  
4mm Allen Wrench  
3mm Allen Wrench  
T30 Torx Wrench  
T20 Torx Wrench

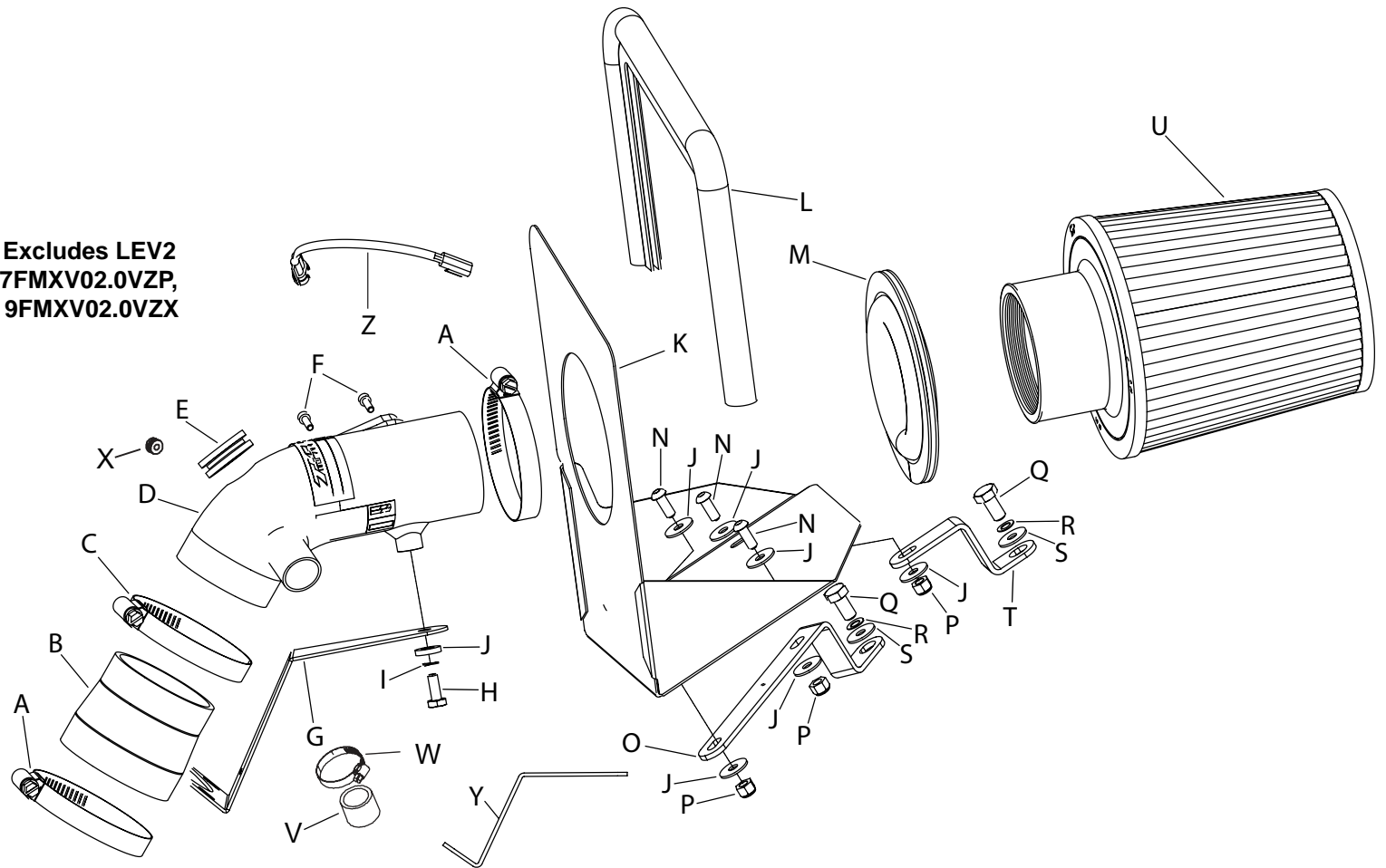

### PARTS LIST:

Description	Qty.	Part #	Description	Qty.	Part #	Description	Qty.	Part #
A Hose Clamp #40	2	08554	J Washer; 6mm, Flat, SS	7	08269	S Washer; 5/16" ID X 5/8" OD, Flat	2	08276
B Hose; 2-1/2" to 2-3/4" TPRD; BLK	1	084016	K Heat Shield	1	07651	T Bracket; Z, Mild Stl, FB/PC	1	06488
C Hose Clamp #36	1	08530	L Edge Trim 20"	1	102494	U Air Filter	1	RU-4950
D Intake Tube	1	27529	M Edge Trim 17"	1	102469	V Cap Plug; 15/16" ID, 3/4" L	1	08246
E Grommet; 1-1/8" OD, 5/8" ID, 5/16" TK	1	08053	N Bolt; M6 X 1.00 X 16mm, BTNHD	3	07730	W Hose Clamp #16	1	08413
F Bolt; M4 - 0.07 8mm, A/H Cap, SS	2	07733	O Bracket; Z, STL, FB/PC	1	06486	X Grommet; 15/16" OD, 3/8" ID	1	08100
G Bracket; Z, STL, FB/PC	1	06487	P Nut; 6mm Nylock, Hex	3	07553	Y Bracket; "Z", STL, TK/PC	1	083133
H Bolt; 6mm - 1.00 X 16mm, SS	1	07812	Q Bolt; 8mm - 1.25 X 16mm, Hex	2	07844	Z MAF Extension Harness	1	21780
I Washer; 1/4" Lock, ZN	1	08198	R Washer; 8mm Spring (Wave)	2	08239			

**NOTE: FAILURE TO FOLLOW INSTALLATION INSTRUCTIONS AND NOT USING THE PROVIDED HARDWARE MAY DAMAGE THE INTAKE TUBE, THROTTLE BODY AND ENGINE.**

### TO START:

1. Turn off the ignition and disconnect the negative battery cable.

**NOTE: Disconnecting the negative battery cable erases pre-programmed electronic memories. Write down all memory settings before disconnecting the negative battery cable. Some radios will require an anti-theft code to be entered after the battery is reconnected. The anti-theft code is typically supplied with your owner's manual. In the event your vehicles' anti-theft code cannot be recovered, contact an authorized dealership to obtain your vehicles anti-theft code.**



2. Remove the crankcase vent hose by pressing the green locking tab and gently pulling the crankcase vent hose away from the fitting.

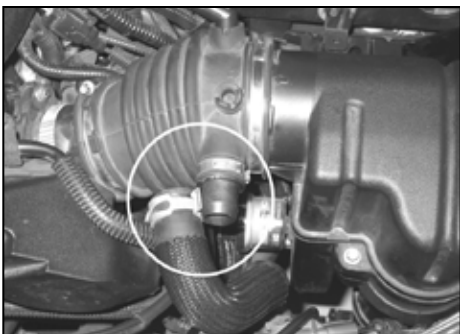

3. On vehicles equipped with an air injection pump; using pliers, release the spring clamp that fastens the air injection hose to the stock intake tube. Disconnect the air injection hose from the stock intake tube.

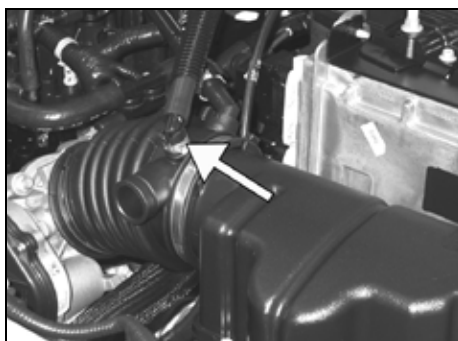

3a. On vehicles equipped with an EVAP vent line, cut the clamp that secures the vent line elbow to the stock intake tube. Then, remove the EVAP vent from the intake tube as shown.

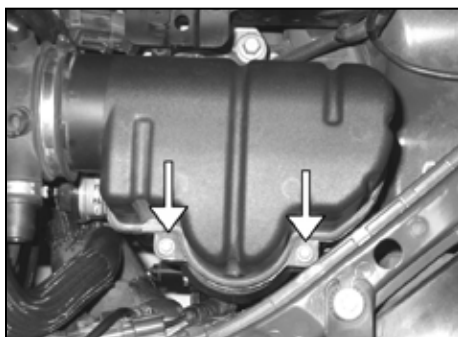

4. Loosen the two bolts that fasten the upper intake housing to the mass air sensor housing.



5. Loosen the hose clamp at the throttle body, then lift firmly, separating the upper intake housing from the mass air sensor housing and throttle body. Remove the upper intake housing.



6. Disconnect the mass air sensor electrical connection. Press the locking tab, then gently pull away from the housing.

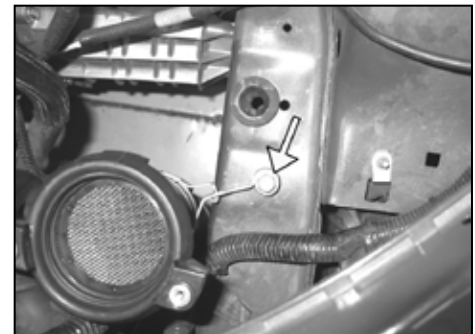

7. Remove the bolt that fastens the mass air sensor housing bracket to the inner fender.



8. Loosen the hose clamp that fastens the mass air sensor housing to the air filter housing, then remove the mass air sensor housing.

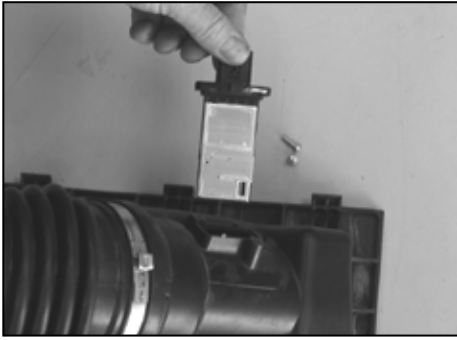

8a. Remove the two screws that fasten the mass air sensor to the factory airbox, then remove the mass air sensor.

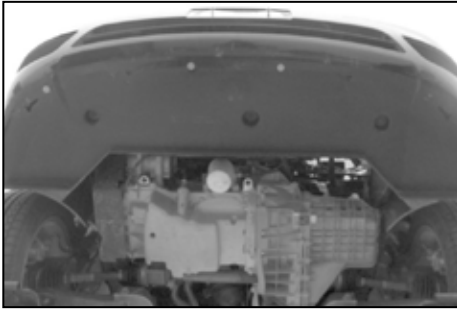

8b. On vehicles equipped with the splash shield, remove the six bolts and five black plastic screws which secure the splash shield to the bumper cover, then remove the splash shield from the vehicle.

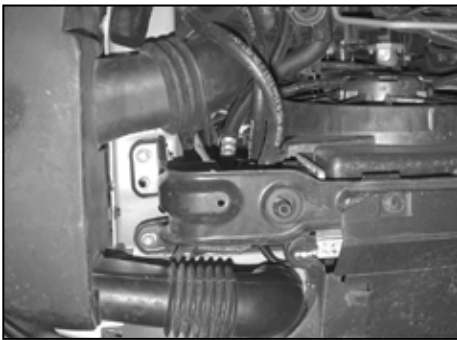

8c. On vehicle's equipped with an airbox cover, remove the two bolts which secure the cover to the frame rail, and the bolt which secures the intake snorkel to the radiator core support.

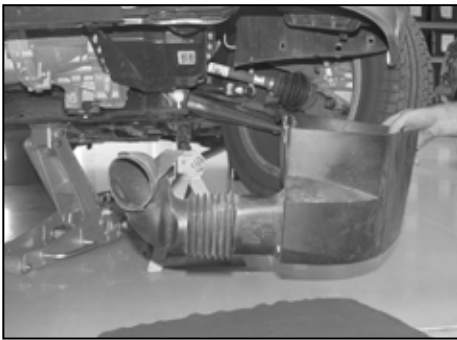

8d. On vehicles equipped with an airbox cover, lower the cover and remove it from the vehicle.

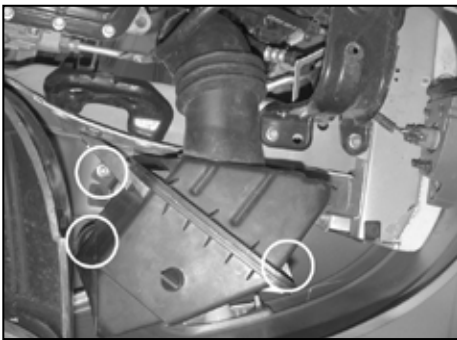

9. Remove the three bolts that fasten the lower airbox to the inner fender well.  
**NOTE: K&N Engineering, Inc., recommends that customers do not discard factory air intake.**



10. Lower and remove the airbox assembly from the vehicle.  
**NOTE: On vehicles equipped with the intake snorkel on top of the airbox behind the fender, it will be necessary to separate the snorkel from the airbox during airbox removal.**



11. On vehicles equipped with the upper intake snorkel, pull down on the snorkel to dislodge it from the mount and then remove it from behind the fender.

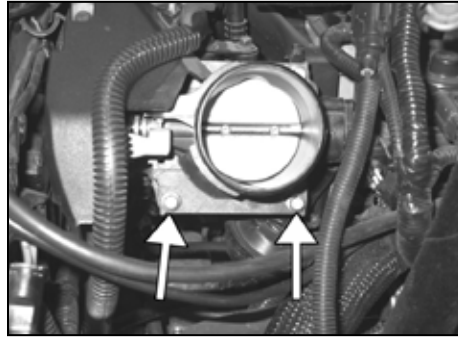

12. On 2008 and earlier models, remove the two lower throttle body bolts shown.  
**NOTE: These bolts will be re-used in step 13.**

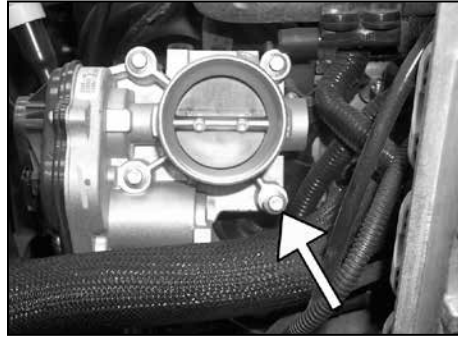

12a. On 2009 model vehicles, remove the lower rear throttle body mounting bolt shown.  
**NOTE: This bolt will be reused in step 13a.**

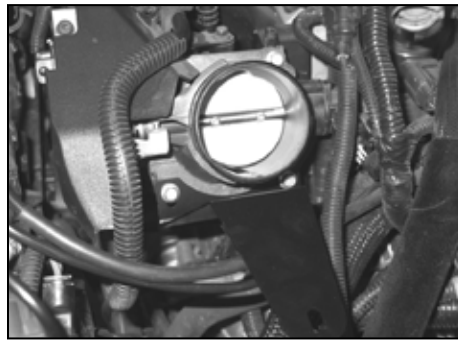

13. On 2008 and earlier models, Install the intake tube mounting bracket (06487) onto the throttle body as shown and secure with the factory mounting bolts from step # 12.

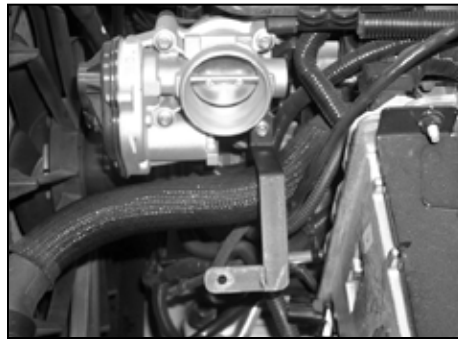

13a. On 2009 models, install the tube mounting bracket (083133) onto the throttle body and secure with the factory mounting bolt from step 12a.



13b. On vehicle's that were equipped with an airbox cover, reinstall and secure with the bolts that were removed in step #8c.

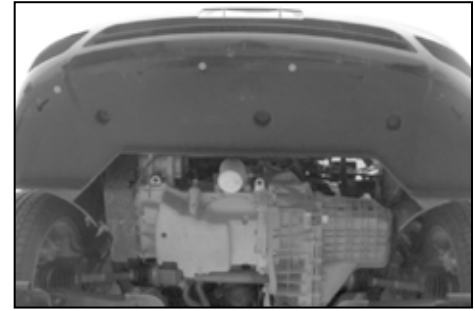

13c. On vehicle's that were equipped with the splash shield, reinstall with the bolts removed in step #8b.

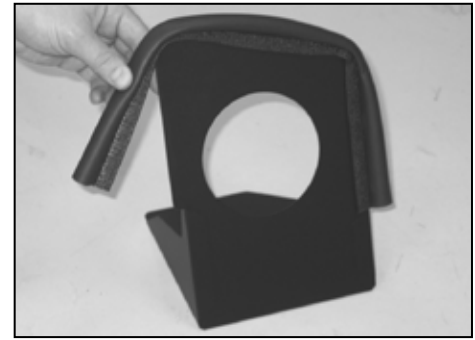

14. Install the edge trim onto the heat shield.  
**NOTE: Some trimming of the edge trim may be necessary.**



15. Install the edge trim onto the center portion of the heat shield.  
**NOTE: Some trimming of the edge trim may be necessary.**

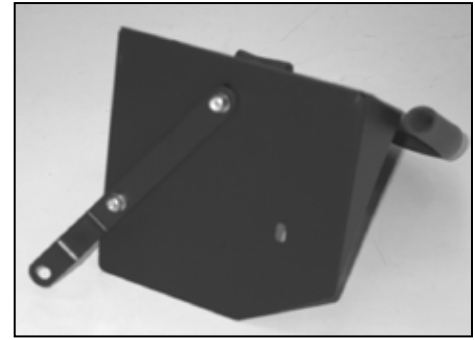

16. Install the heat shield mounting bracket (06486) onto the bottom of the heat shield; fasten using the provided hardware.



17. Install the heat shield mounting bracket (06488) onto the inner fender; fasten using the provided hardware.

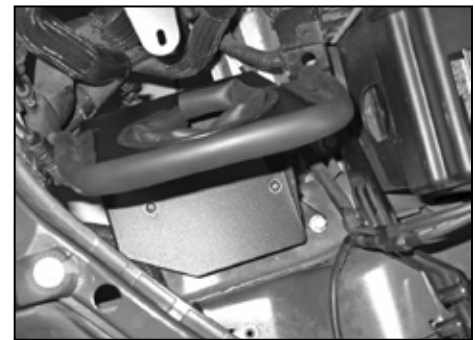

18. Place the heat shield into position onto the inner fender well heat shield mounting bracket and align the second heat shield bracket with the threaded hole in the inner fender. Fasten the heat shield using the provided hardware.

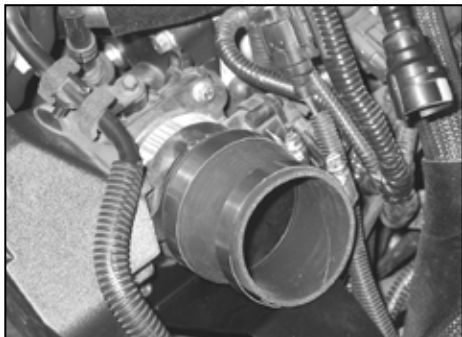

19. Install the silicone hose (084016) onto the throttle body and fasten with the provided hose clamp.



19a. On vehicles equipped with an EVAP vent line, drill a 5/8" I.D. hole in the tube at the location shown.

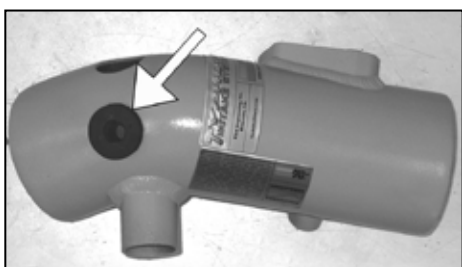

19b. On vehicles equipped with an EVAP vent line, install the provided grommet into the hole drilled in step #19a.



19c. On vehicles not equipped with an air injection pump, install the provided caplug onto the air injection fitting and secure with the provided hose clamp as shown.



20. Remove the two screws that fasten the mass air sensor to the mass air sensor housing, then remove the mass air sensor from the housing.



21. Install the mass air sensor into the K&N® intake tube, then fasten using the provided hardware.



22. Remove the crankcase vent fitting from the stock intake tube.

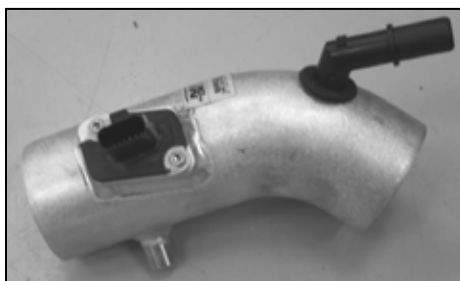

23. Install the provided grommet and stock crankcase vent fitting into the K&N® intake tube.



24. Install the K&N® intake tube into the silicone hose previously installed onto the throttle body. Align the intake tube with the previously installed intake tube mounting bracket; fasten using the respective hose clamp and hardware.



25. Install the K&N® air filter and fasten using the provided hose clamp.

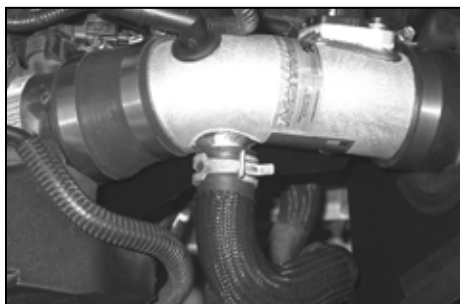

26. Connect the air injection hose to the K&N® intake tube and fasten using the stock spring clamp.

**NOTE: On vehicles equipped with the EVAP vent hose, insert the 90 degree fitting into the grommet installed in step #19b.**



27. Connect the crankcase vent hose to the stock fitting previously installed into the K&N® intake tube.

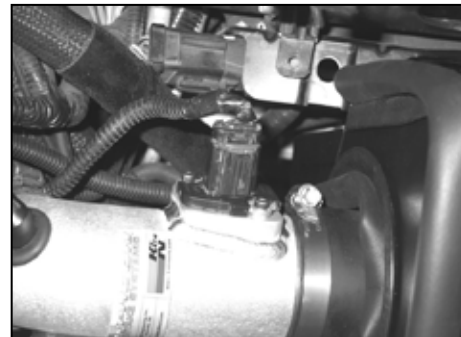

28. Re-connect the mass air sensor electrical connection.

**NOTE: On 2009 models, it will be necessary to use the provided mass air sensor extension harness.**



29. Reconnect the vehicle's negative battery cable. Double check to make sure everything is tight and properly positioned before starting the vehicle.

30. The C.A.R.B. exemption sticker, (attached), must be visible under the hood, so the emissions inspector can see it when the vehicle is required to be tested for emissions. California requires testing every two years, other states may vary.

31. It will be necessary for all K&N® high flow intake systems to be checked periodically for realignment, clearance and tightening of all connections. Failure to follow the above instructions or proper maintenance may void warranty.

#### ROAD TESTING:

1. Start the engine with the transmission in neutral or park, and the parking brake engaged. Listen for air leaks or odd noises. For air leaks secure hoses and connections. For odd noises, find cause and repair before proceeding. This kit will function identically to the factory system except for being louder and much more responsive.

2. Test drive the vehicle. Listen for odd noises or rattles and fix as necessary.

3. If road test is fine, you can now enjoy the added power and performance from your kit.

4. K&N Engineering, Inc., suggests checking the air filter element periodically for excessive dirt build-up. When the element becomes covered in dirt (or once a year), service it according to the instructions on the Recharger® service kit, part number 99-5050 or 99-5000.