

K&N TYPHOON INTAKE SYSTEMS

INSTALLATION INSTRUCTIONS

69-3303TS

FIAT

2012-15 500

L4-1.4L

NOTE: Fits vehicles with automatic transmissions only.

TOOLS NEEDED:

Flat Blade Screw Driver
Extension
7/16" Socket
10mm Socket
8mm Socket
Pliers/Cutters
Ratchet

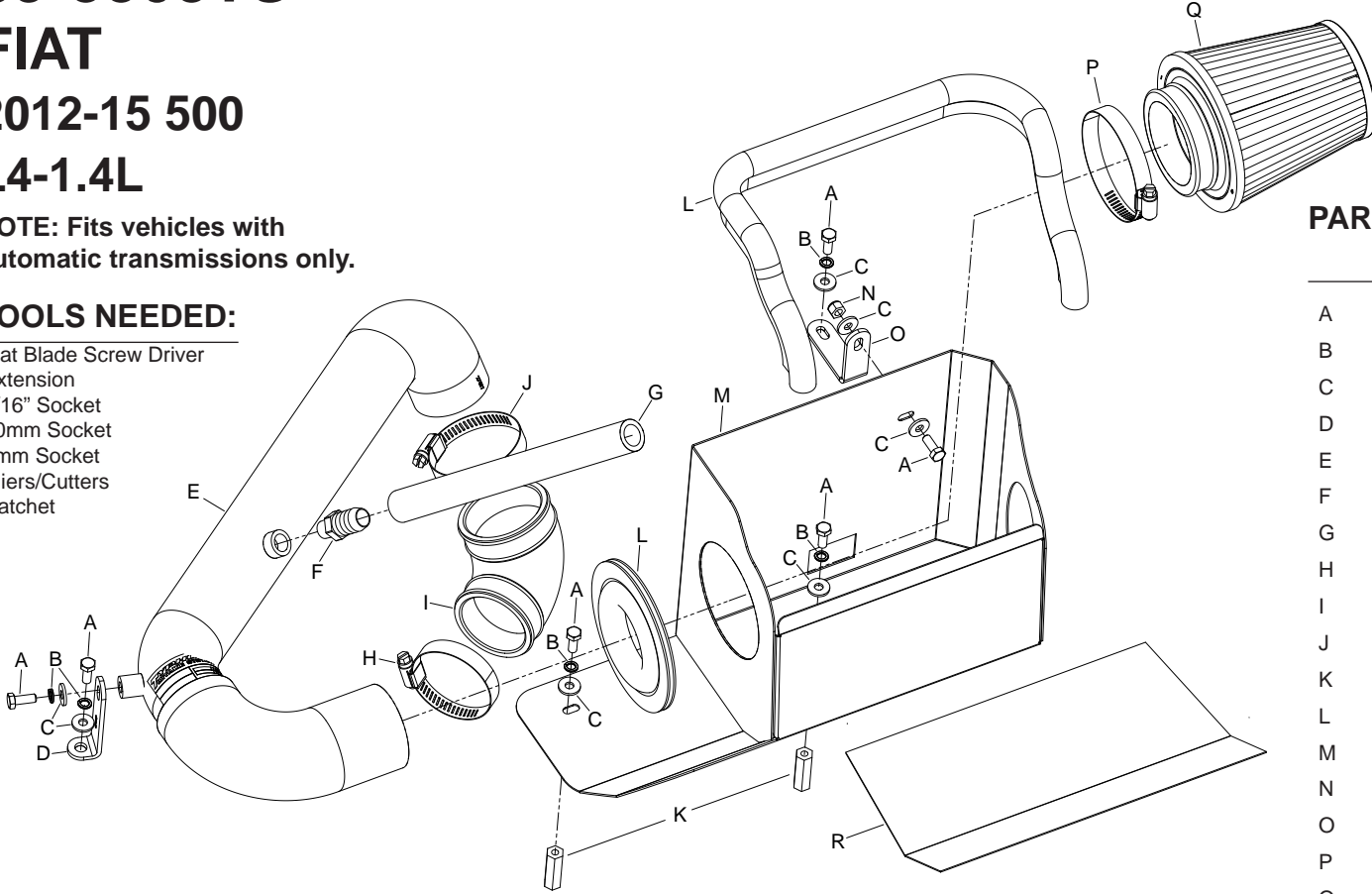

PARTS LIST:

	Description	Qty.	Part #
A	Bolt; 6MM-1.00 X 16MM, SS	6	07812
B	Washer, M6 Split Lock Zinc	5	1-3025
C	Washer; 1/4"ID X 5/8 OD-SAE	7	08275
D	Bracket; 57-1532, SM. "L", Mild	1	07158
E	Intake Tube	1	27597TS
F	Vent; STRT, 5/8 Barbed 1/4 NPT	1	08911
G	Hose; 5/8"ID X 9-3/4"L	1	084047
H	Hose Clamp #32	1	08507
I	Hose; Elbow; 90, 2.25 ID/2.0 ID	1	03108
J	Hose Clamp #36	1	08530
K	Nut; 6MM X 1.00"L, Coupling	2	08254
L	Edge Trim (35")	1	102471
M	Heat Shield	1	073131
N	Nut; 6MM Nylock, Hexhead, SS	1	07512
O	Bracket; 57-1509, "L", FIN	1	070662
P	Hose Clamp #44	1	08577
Q	Air Filter	1	RC-9800
R	Adhesive Heat Barrier, 11.7 X 6"	1	8-165

NOTE: FAILURE TO FOLLOW INSTALLATION INSTRUCTIONS AND NOT USING THE PROVIDED HARDWARE MAY DAMAGE THE INTAKE TUBE, THROTTLE BODY AND ENGINE.

TO START:

1. Turn off the ignition and disconnect the negative battery cable.

NOTE: Disconnecting the negative battery cable erases pre-programmed electronic memories. Write down all memory settings before disconnecting the negative battery cable. Some radios will require an anti-theft code to be entered after the battery is reconnected. The anti-theft code is typically supplied with your owner's manual. In the event your vehicles' anti-theft code cannot be recovered, contact an authorized dealership to obtain your vehicles anti-theft code.



2. Lift up the engine cover and remove it from the engine.



3. Loosen the hose clamp securing the intake tube to the throttle body.

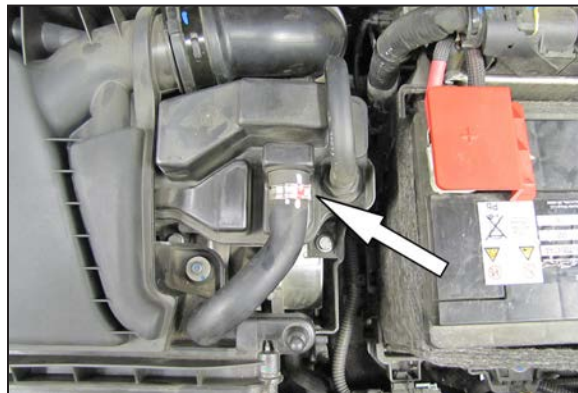

4. Cut the clamp securing the crank case vent hose to plenum and then disconnect the crank case vent hose from the plenum.



5. Disconnect the fresh air intake hose from the intake plenum.

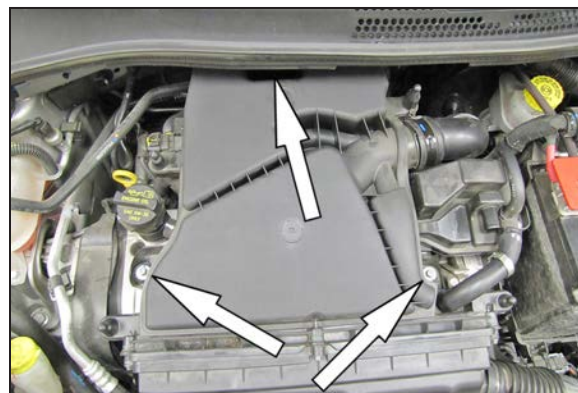

6. Loosen the three bolts securing the intake plenum to the engine.



7. Lift up and remove the complete stock intake system from the engine.
NOTE: K&N Engineering, Inc., recommends that customers do not discard factory air intake.



8. Install the provided elbow hose (03108) onto the throttle body as shown.
NOTE: Do not completely tighten at this time.

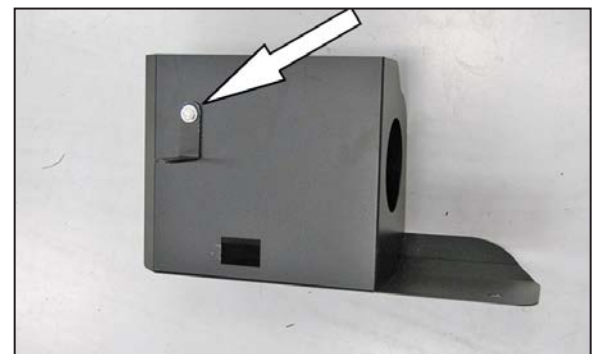

9. Install the provided "L" bracket (070662) onto the heat shield as shown.
NOTE: The shorter leg of the bracket will be attached to the heat shield.

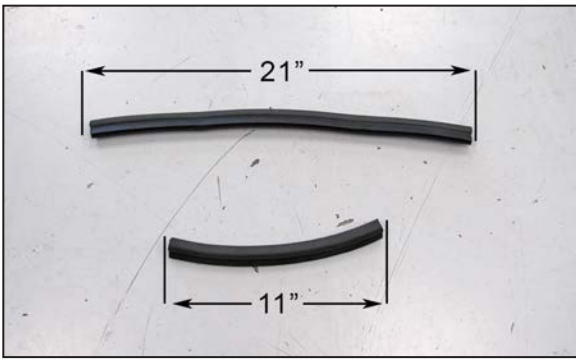

10. Cut the provided edge trim into two sections, one section will be 21" long and the shorter section will be 11" long.

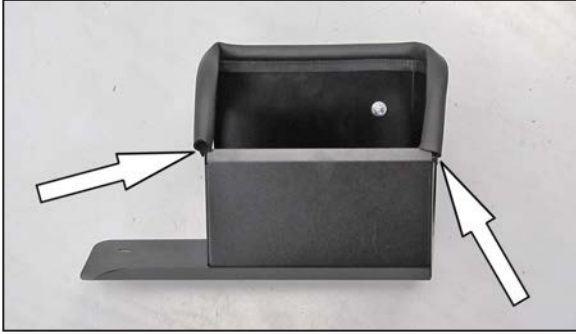

11. Install the 21" edge trim onto the heat shield as shown.

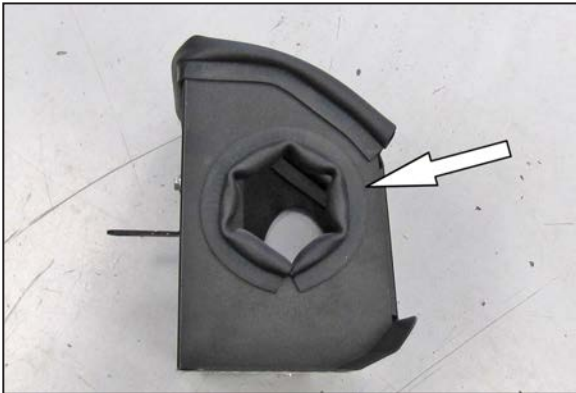

12. Install the 11" edge trim into the hole of the heat shield as shown.

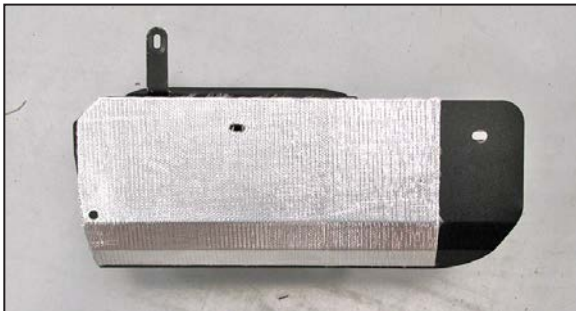

13. Install the heat barrier onto the heat shield as shown.

NOTE: Some trimming of the heat barrier will be necessary including trimming for the bolt hole.



14. Remove the two exhaust manifold heat shield nuts shown.

NOTE: it is recommended to apply some penetrating oil on the threads before trying to remove the nuts.



15. Install the two nut extensions onto the heat shield mounting studs as show.



16. Set the heat shield onto the nut extensions, snap the fresh air duct into the heat shield and then secure the heat shield to the nut extensions and valve cover with the provided hardware.



17. Install the provided 5/8" vent fitting into the K&N® intake tube as shown.

NOTE: Plastic NPT fittings are easy to cross thread. Install the vent fitting "hand" tight, then turn it two complete turns with a wrench.



18. Install the K&N® intake tube into the heat shield and then into the silicone hose at the throttle body.

NOTE: Do not secure at this time.

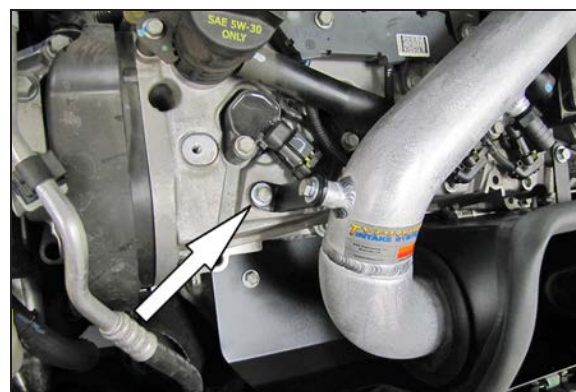

19. Install the provided tube mounting bracket (07158) onto the valve cover and intake tube with the provided hardware. Secure the hose clamps on the silicone elbow hose.

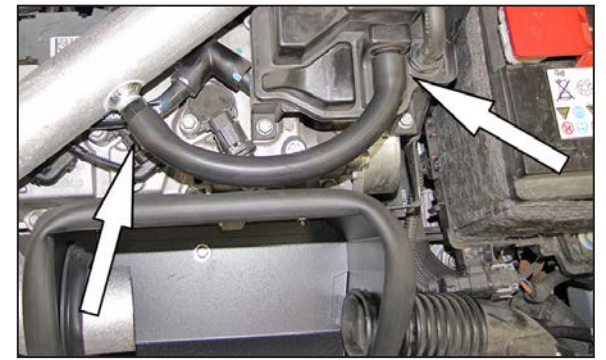

20. Attach the provided crank case vent hose to the fitting on the K&N® intake tube and the factory plenum.



21. Install the K&N® air filter and secure with the provided hose clamp.



22. Reconnect the vehicle's negative battery cable. Double check to make sure everything is tight and properly positioned before starting the vehicle.

23. The C.A.R.B. exemption sticker, (attached), must be visible under the hood so that an emissions inspector can see it when the vehicle is required to be tested for emissions. California requires testing every two years, other states may vary.

24. It will be necessary for all K&N® high flow intake systems to be checked periodically for realignment, clearance and tightening of all connections. Failure to follow the above instructions or proper maintenance may void warranty.

ROAD TESTING:

1. Start the engine with the transmission in neutral or park, and the parking brake engaged. Listen for air leaks or odd noises. For air leaks secure hoses and connections. For odd noises, find cause and repair before proceeding. This kit will function identically to the factory system except for being louder and much more responsive.

2. Test drive the vehicle. Listen for odd noises or rattles and fix as necessary.

3. If road test is fine, you can now enjoy the added power and performance from your kit.

4. K&N Engineering, Inc., requires cleaning the intake system's air filter element every 100,000 miles. When used in dusty or off-road environments, our filters will require cleaning more often. We recommend that you visually inspect your filter once every 25,000 miles to determine if the screen is still visible. When the screen is no longer visible some place on the filter element, it is time to clean it. To clean and re-oil, purchase our filter Recharger® service kit, part number 99-5050 or 99-5000 and follow the easy instructions.