



TYPHOON INTAKE SYSTEMS

INSTALLATION INSTRUCTIONS

69-2547TS
DODGE
2013-16 Dart
L4-2.0L

TOOLS NEEDED:

- Ratchet
- Extension
- 13mm socket
- 10mm socket
- 7mm socket
- 10mm wrench
- Flat blade screw driver

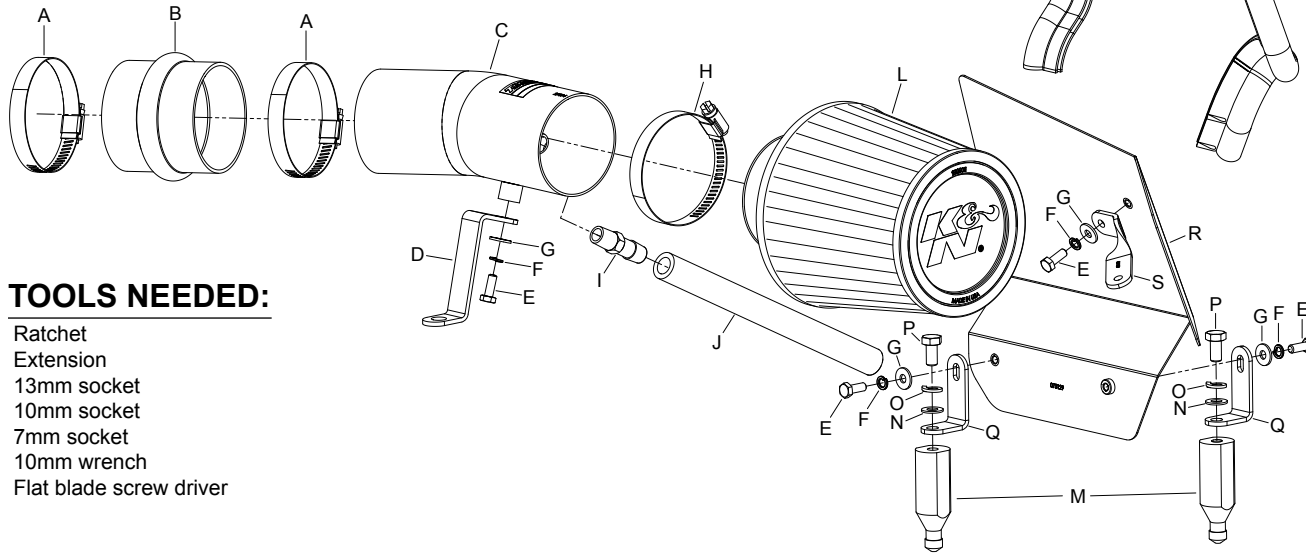

PARTS LIST:

Description	Qty.	Part #
A Hose Clamp #44 Stainless	2	08560
B Hose, 3" ID X 3"L Hump	1	08696
C Intake Tube	1	27594TS
D Bracket; Z, 69-2547, STL, TB/PC	1	064301
E Bolt; 6MM-1.00 X 16MM, SS	4	07812
F Washer; M6 Split Lock Zinc	4	1-3025
G Washer; 6Mm Flat, SS	4	08269
H Hose Clamp #52	1	08610
I Vent; STRT 1/2" Hose, 1/4:NPT	1	080022
J Hose; 1/2" ID X 9"L	1	08401
K Edge Trim (30")	1	102489
L Air Filter	1	RU-4990
M Standoff; 6.0 Ford Air box	2	06532
N Washer; 5/16" ID X 5/8"OD, Flat	2	08276
O Washer, M8 Split Lock Zinc	2	1-3036
P Bolt; 8MM-1.25 X 16MM	2	07844
Q Bracket; 57-301, L-Bend, FIN	2	070812
R Heat Shield	1	073129
S Bracket; 57-1528, SM. Twist, Mild	1	07139

NOTE: FAILURE TO FOLLOW INSTALLATION INSTRUCTIONS AND NOT USING THE PROVIDED HARDWARE MAY DAMAGE THE INTAKE TUBE, THROTTLE BODY AND ENGINE.

TO START:

1. Turn off the ignition and disconnect the negative battery cable.
NOTE: Disconnecting the negative battery cable erases pre-programmed electronic memories. Write down all memory settings before disconnecting the negative battery cable. Some radios will require an anti-theft code to be entered after the battery is reconnected. The anti-theft code is typically supplied with your owner's manual. In the event your vehicles' anti-theft code cannot be recovered, contact an authorized dealership to obtain your vehicles anti-theft code.



2. Loosen the hose clamp securing the intake hose to the intake plenum.



3. Disconnect the crank case vent hose from the air filter housing



4. Remove the bolt securing the air filter housing onto the core support and unhook the coolant line from the air box.
NOTE: This bolt will be reused in a later step.



5. Lift up and remove the air filter housing assembly from the vehicle.
NOTE: K&N Engineering, Inc., recommends that customers do not discard factory air intake.



6. Disconnect the inlet air temperature sensor electrical connection and then loosen the hose clamp securing the intake plenum to the throttle body.



7. Lift up and remove the intake plenum from the vehicle.



8. Remove the crank case vent hose from the valve cover port.



9. Install the provided shorter crank case vent hose.



10. Reinstall the intake plenum and reconnect the inlet air temperature electrical connection, secure the plenum with the factory hose clamp.



11. Install the provided edge trim onto the heat shield as shown.
NOTE: Some trimming of the edge trim will be necessary.



12. Install one of the provided brackets #070812 onto the heat shield as shown using the provided hardware.



13. Flip the heat shield over and install the remaining bracket #070812 and secure with the provided hardware.



14. Install the two heat shield mounts onto the brackets as shown.



15. Install the final heat shield mounting bracket #07139 onto the heat shield and secure using the provided hardware.



16. Remove the front engine mounting bolt shown.



17. Install the tube mounting bracket #064301 onto the engine mount and secure with the factory bolt from the previous step.

NOTE: The bracket will need to be adjusted for best fit once the kit is fully assembled.



18. Install the heat shield mounts into the factory mounting grommets and then secure mounting bracket to the core support with the factory air box mounting bolt.



19. Install the provided hump hose #08696 onto the plenum inlet and secure with the provided hose clamp.



20. Install the crank case vent fitting into the K&N® intake tube as shown.

NOTE: Plastic NPT fittings are easy to cross thread. Install the vent fitting "hand" tight, then turn it two complete turns with a wrench.



21. Install the K&N® intake tube into the silicone hose and align with the mounting bracket previously installed. Secure the tube with the provided hardware and hose clamp.



22. Connect the crank case vent hose to the fitting installed into the K&N® intake tube.



23. Install the K&N® air filter and secure with the provided hose clamp.
NOTE: Drycharger® air filter wrap; part # RX-4990DK is available to purchase separately.



24. Reconnect the vehicle's negative battery cable. Double check to make sure everything is tight and properly positioned before starting the vehicle.

25. It will be necessary for all K&N® high flow intake systems to be checked periodically for realignment, clearance and tightening of all connections. Failure to follow the above instructions or proper maintenance may void warranty.

ROAD TESTING:

1. Start the engine with the transmission in neutral or park, and the parking brake engaged. Listen for air leaks or odd noises. For air leaks secure hoses and connections. For odd noises, find cause and repair before proceeding. This kit will function identically to the factory system except for being louder and much more responsive.

2. Test drive the vehicle. Listen for odd noises or rattles and fix as necessary.

3. If road test is fine, you can now enjoy the added power and performance from your kit.

4. K&N Engineering, Inc., requires cleaning the intake system's air filter element every 100,000 miles. When used in dusty or off-road environments, our filters will require cleaning more often. We recommend that you visually inspect your filter once every 25,000 miles to determine if the screen is still visible. When the screen is no longer visible some place on the filter element, it is time to clean it. To clean and re-oil, purchase our filter Recharger® service kit, part number 99-5050 or 99-5000 and follow the easy instructions.