



TYPHOON INTAKE SYSTEMS

INSTALLATION INSTRUCTIONS

69-1504TR
HONDA
2017 Civic SI
L4-1.4L Turbo

TOOLS NEEDED:

- ratchet
- extension
- 10mm socket
- 3mm allen
- 4mm allen
- phillips screw driver
- flat blade screw driver
- 10mm wrench

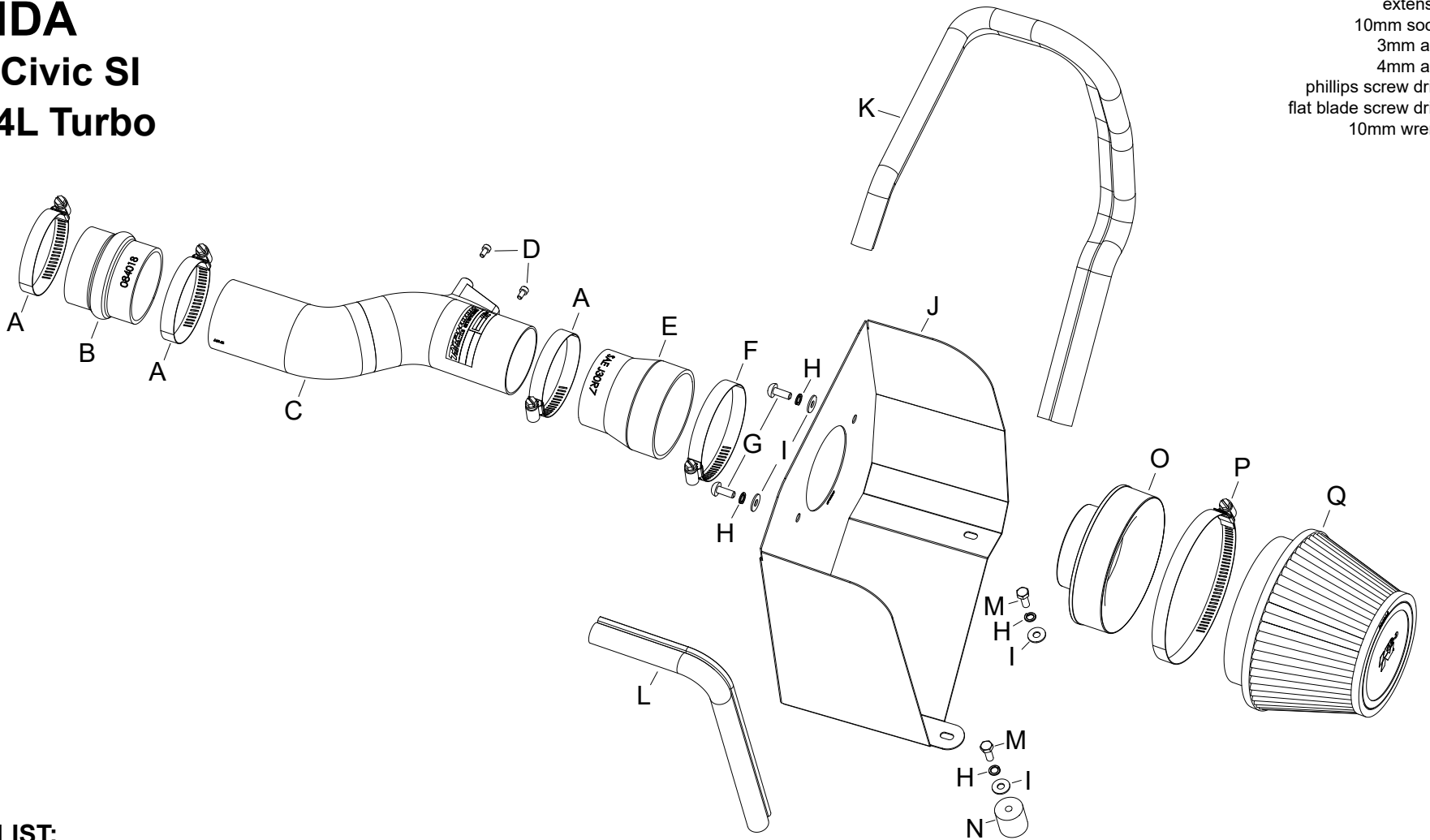

PARTS LIST:

| Description | Qty. | Part # | Description | Qty. | Part # | Description | Qty. | Part # |
|---------------------------------|------|---------|------------------------------|------|--------|-----------------------------|------|---------|
| A HOSE CLAMP #40 | 3 | 08554 | G BOLT; M6 X 1.00 X 16MM, SS | 2 | 07730 | M BOLT; 6MM-1.00 X 16MM, SS | 2 | 07812 |
| B HOSE; 2-1/2" X 2-1/2" L HUMPH | 1 | 084018 | H WASHER, M6 SPLIT LOCK ZINC | 4 | 1-3025 | N STUD; RUBBER MOUNT, M6 | 1 | 02033 |
| C INTAKE TUBE | 1 | 27679TR | I WASHER; 6MM FLAT, SS | 4 | 08269 | O ADAPTER; FILTER, 3.0"OD | 1 | 21569 |
| D BOLT; M4 - 0.07 8MM, A/H CAP | 2 | 07733 | J HEAT SHIELD | 1 | 073235 | P HOSE CLAMP; #80 | 1 | 08694 |
| E HOSE; 3" TO 2-1/2" ID X 3" L | 1 | 08713 | K EDGE TRIM (30") | 1 | 102489 | Q FILTER CHARGER | 1 | RU-5163 |
| F HOSE CLAMP #48 | 1 | 08601 | L EDGE TRIM; 3/4" BULB, SIDE | 1 | 102478 | | | |

NOTE: FAILURE TO FOLLOW INSTALLATION INSTRUCTIONS AND NOT USING THE PROVIDED HARDWARE MAY DAMAGE THE INTAKE TUBE, THROTTLE BODY AND ENGINE.

TO START:

1. Turn off the ignition and disconnect the negative battery cable.
NOTE: Disconnecting the negative battery cable erases pre-programmed electronic memories. Write down all memory settings before disconnecting the negative battery cable. Some radios will require an anti-theft code to be entered after the battery is reconnected. The anti-theft code is typically supplied with your owner's manual. In the event your vehicles anti-theft code cannot be recovered, contact an authorized dealership to obtain your vehicles anti-theft code.



2. Disconnect the mass air sensor electrical connection.



3. Loosen the hose clamp that secures the intake hose to the turbo inlet.



4. Remove the two bolts that secure the factory air filter housing to the inner fender and then remove the complete intake assembly from the vehicle.
NOTE: K&N Engineering, Inc., recommends that customers do not discard factory air intake.



5. Install the K&N® air filter adapter into the heat shield and secure with the provided hardware.

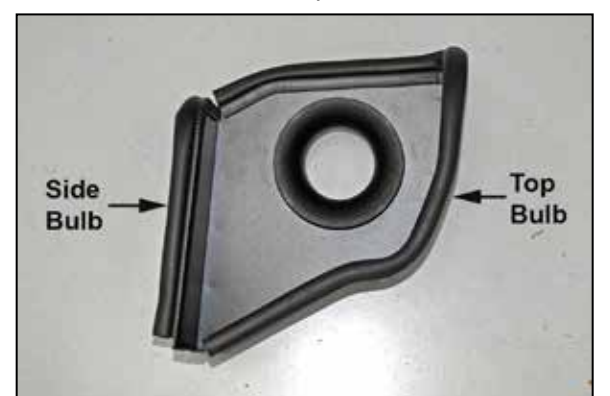

6. Install the provided side bulb and top bulb edge trim onto the heat shield as shown.
NOTE: Some trimming of the edge trim will be necessary.



7. Thread the provided rubber mounted stud into the factory air filter housing location shown.



8. Install the heat shield assembly into the vehicle and secure with the provided hardware to the rubber mounted stud and the rear factory air filter housing mounting location.



9. Flex the heat shield inward and install the K&N® air filter onto the filter adapter and secure with the provided hose clamp.



10. Install the provided coupler (08713) onto the filter adapter and secure with the provided hose clamp.



11. Install the provided hump coupler (084018) onto the turbo inlet and secure with the provided hose clamp.

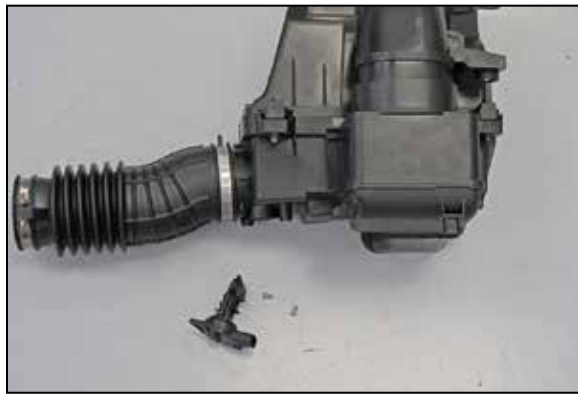

12. Remove the mass air sensor from the factory air filter housing.



13. Install the mass air sensor into the K&N® intake tube and secure using the provided hardware.



14. Remove the bypass hose retaining clip shown and flip it to the other side of the bracket and reinstall, then reinstall the bypass hose into the clip.



15. Install the K&N® intake tube into the hump coupler and then into the step coupler. Adjust the tube for best fit and then secure with the provided hose clamps. Reconnect the mass air sensor electrical connection.



16. Reconnect the vehicle's negative battery cable. Double check to make sure everything is tight and properly positioned before starting the vehicle.

17. It will be necessary for all K&N® high flow intake systems to be checked periodically for realignment, clearance and tightening of all connections. Failure to follow the above instructions or proper maintenance may void warranty.

ROAD TESTING:

1. Start the engine with the transmission in neutral or park, and the parking brake engaged. Listen for air leaks or odd noises. For air leaks secure hoses and connections. For odd noises, find cause and repair before proceeding. This kit will function identically to the factory system except for being louder and much more responsive.

2. Test drive the vehicle. Listen for odd noises or rattles and fix as necessary.

3. If road test is fine, you can now enjoy the added power and performance from your kit.

4. K&N Engineering, Inc., requires cleaning the intake system's air filter element every 100,000 miles. When used in dusty or off-road environments, our filters will require cleaning more often. We recommend that you visually inspect your filter once every 25,000 miles to determine if the screen is still visible. When the screen is no longer visible some place on the filter element, it is time to clean it. To clean and re-oil, purchase our filter Recharger® service kit, part number 99-5050 or 99-5000 and follow the easy instructions.