

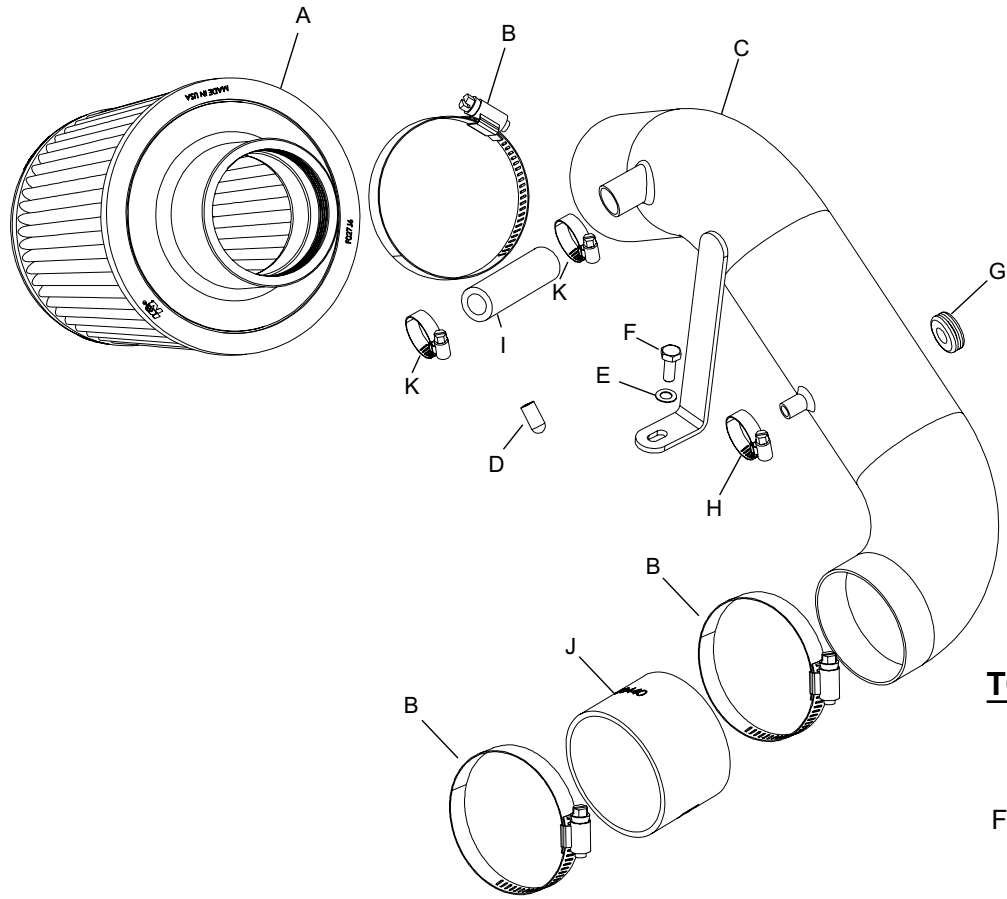

TYPHOON INTAKE SYSTEMS

INSTALLATION INSTRUCTIONS

69-1009TP
69-1009TR
69-1009TWR
ACURA / HONDA
2002-06 RSX Type-S
L4-2.0L
2002-05 Civic Si
L4-2.0L



TOOLS NEEDED:

- 6" Extension
- 8mm Socket
- 10mm Socket
- Flatblade Screwdriver
- Pliers
- Ratchet

PARTS LIST:

Description	Qty.	Part #	Description	Qty.	Part #	Description	Qty.	Part #
A Air Filter	1	RU-4870	E Wave Washer	1	08277	I Hose; 5/8"ID, 2-1/4"L, Rubber	1	08692
B Hose Clamp, #44 SS	3	08560	F 6mm Hex bolt, 16mm L.	1	07812	J Silicone Hose Black	1	08440
C Intake Tube	1	27081	G Grommet	1	08283	K Hose Clamp, #10 mini	2	08411
D Rubber Cap	1	08282	H Hose Clamp, #004	1	21850			

NOTE: FAILURE TO FOLLOW INSTALLATION INSTRUCTIONS AND NOT USING THE PROVIDED HARDWARE MAY DAMAGE THE INTAKE TUBE, THROTTLE BODY AND ENGINE.

TO START:

1. Turn off the ignition and disconnect the negative battery cable.

NOTE: Disconnecting the negative battery cable erases pre-programmed electronic memories. Write down all memory settings before disconnecting the negative battery cable. Some radios will require an anti-theft code to be entered after the battery is reconnected. The anti-theft code is typically supplied with your owner's manual. In the event your vehicles' anti-theft code cannot be recovered, contact an authorized dealership to obtain your vehicles anti-theft code.



2. Loosen and remove the two bolts that secure the engine cover, then remove the engine cover as shown.



3. Using a pair of pliers, depress the hose clamp and slide it back off of the crank case vent on the air cleaner assembly as shown.



4. Using a pair of pliers, depress the hose clamp and remove the air temperature sensor from the stock intake tube as shown.

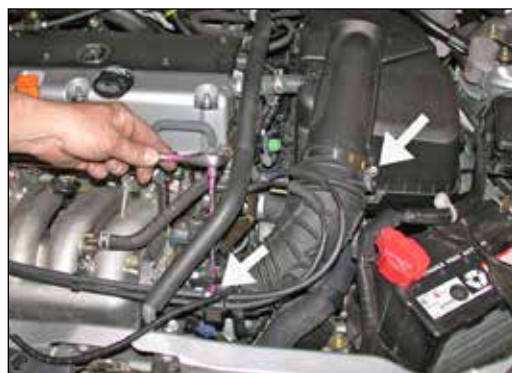

5. Loosen the two hose clamps at the throttle body and at the air cleaner assembly as shown.



6. Remove the Idle air bypass control thermal valve vent hose from the vent on the stock intake tube as shown.



7. Loosen the stock hose clamp.



8. Loosen the 5 bolts and pull upwards to remove the upper air cleaner assembly as shown.



9. Pull the stock intake tube off of the throttle body, then remove the stock intake tube as shown.



10. Loosen and remove the two bolts and one nut on the lower air cleaner assembly as shown.



11. Pull upwards to remove the lower air cleaner assembly as shown.



12. Using a 10mm socket, loosen the bolt that secures the air inlet duct as shown.



13. Remove the air inlet duct as shown.
NOTE: K&N Engineering, Inc., recommends that customers do not discard factory air intake.



14. **2005-06 Model Year Vehicles ONLY:** On '05-'06 models, remove the stock crank case vent hose as shown.



15. **2005-06 Model Year Vehicles ONLY:** On '05-'06 models, place hose clamps on each side of the silicone hose (08692), as shown.



16. Install the silicone hose and hose clamp onto the throttle body as shown.
NOTE: It may be necessary to fully open the hose clamp so it will slide over the throttle body.



17. Install the provided grommet into the hole on the K&N® intake tube as shown.



18. Install the second hose clamp onto the silicone hose, then, slide the K&N® intake tube into the silicone hose as shown. Line up the intake tube bracket with the original air cleaner mounting point.



19. **2005-06 Model Year Vehicles ONLY:** Using the supplied silicone hose and hose clamps, secure the silicone hose to the stock crank case vent line and to the vent tube on the intake tube as shown.



20. Using a 10mm socket secure the bracket to the air cleaner mounting point using the provided hardware.



21. Using a flat blade screwdriver, tighten the hose clamp on the silicone hose as shown.



22. Reconnect the idle air bypass control thermal valve vent hose to the vent on the K&N® intake tube and secure with the provided hose clamp as shown.



23. Push the air temperature sensor into the grommet on the K&N® intake tube as shown.



24. Install the K&N® air filter onto the K&N® intake tube and secure with the provided hose clamp as shown.



25. Install the rubber cap plug onto the stand off on the engine cover as shown.



26. Reinstall the engine cover as shown.



27. Reconnect the vehicle's negative battery cable. Double check to make sure everything is tight and properly positioned before starting the vehicle.

28. The C.A.R.B. exemption sticker, (attached), must be visible under the hood, so the emissions inspector can see it when the vehicle is required to be tested for emissions. California requires testing every two years, other states may vary.

29. It will be necessary for all K&N® high flow intake systems to be checked periodically for realignment, clearance and tightening of all connections. Failure to follow the above instructions or proper maintenance may void warranty.

ROAD TESTING:

1. Start the engine with the transmission in neutral or park, and the parking brake engaged. Listen for air leaks or odd noises. For air leaks secure hoses and connections. For odd noises, find cause and repair before proceeding. This kit will function identically to the factory system except for being louder and much more responsive.

2. Test drive the vehicle. Listen for odd noises or rattles and fix as necessary.

3. If road test is fine, you can now enjoy the added power and performance from your kit.

4. K&N Engineering, Inc., requires cleaning the intake system's air filter element every 100,000 miles. When used in dusty or off-road environments, our filters will require cleaning more often. We recommend that you visually inspect your filter once every 25,000 miles to determine if the screen is still visible. When the screen is no longer visible some place on the filter element, it is time to clean it. To clean and re-oil, purchase our filter Recharger® service kit, part number 99-5050 or 99-5000 and follow the easy instructions.