

K&N® TYPHOON INTAKE SYSTEMS

INSTALLATION INSTRUCTIONS

69-0026TS

ACURA

2009-14 TSX

L4-2.4L

TOOLS NEEDED:

Ratchet
Extension
10mm Socket
10mm Wrench
Flat Blade Screwdriver
Phillips Screwdriver
Pliers

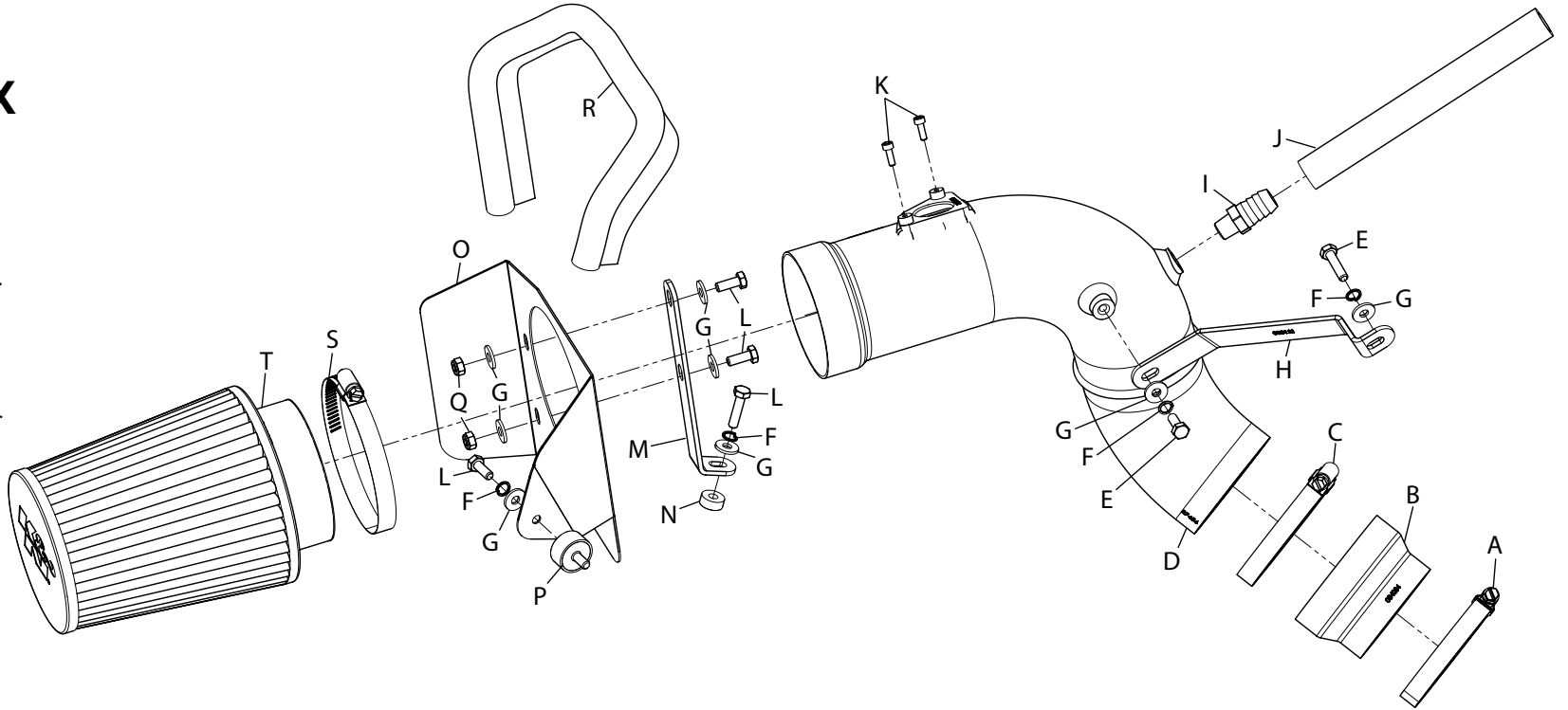

PARTS LIST:

Description	Qty.	Part #	Description	Qty.	Part #	Description	Qty.	Part #
A Hose Clamp #44 Stainless	1	08560	H Bracket; "Z", STL, TK/PC	1	083121	O Heat Shield	1	073117
B Hose; 3-1/4" To 2-3/4" ID x 2" L	1	084034	I Vent; Strt, 5/8 Barbed 1/4 NPT	1	08911	P Stud; M/F, 1/2"Lx1"W, M6x1.00	1	070228
C Hose Clamp #48	1	08601	J Hose; 5/8" ID x 7-1/2" L	1	084008	Q Nut; 6mm Nylcok, Hexhead, SS	2	07512
D Intake Tube	1	27456TS	K Bolt; M6-1.00 x 25mm, SS	2	07858	R Edge Trim (26")	1	102488
E Bolt; M4-0.07 8mm, A/H CAP, SS	2	07733	L Bolt; 6mm-1.00 x 16mm, SS	4	07812	S Hose Clamp #60	1	08624
F Washer; 1/4" Lock, ZN	4	08198	M Bracket; "L", STL, TK/PC	1	083120	T Air Filter	1	RC-4630XD
G Washer; 1/4"ID x 5/8"OD - SAE	8	08275	N Spacer: .625"ODx.250"IDx.250"L	1	06555			

NOTE: FAILURE TO FOLLOW INSTALLATION INSTRUCTIONS AND NOT USING THE PROVIDED HARDWARE MAY DAMAGE THE INTAKE TUBE, THROTTLE BODY AND ENGINE.

TO START:

1. Turn off the ignition and disconnect the negative battery cable.

NOTE: Disconnecting the negative battery cable erases pre-programmed electronic memories. Write down all memory settings before disconnecting the negative battery cable. Some radios will require an anti-theft code to be entered after the battery is reconnected. The anti-theft code is typically supplied with your owner's manual. In the event your vehicles' anti-theft code cannot be recovered, contact an authorized dealership to obtain your vehicles anti-theft code.



2. Disconnect the mass air sensor electrical connection.



3. Loosen the hose clamps which secure the stock intake tube to the throttle body and air filter assembly.



4. Release the spring clamp and disconnect the crank case vent tube from the intake tube.



5. Remove the intake tube from the vehicle.



6. Loosen the two bolts securing the air box assembly to the inner fender and ECU bracket.



7. Remove the air filter assembly from the vehicle. **NOTE: K&N Engineering, Inc., recommends that customers do not discard factory air intake.**



8. Remove the rear air filter mounting bracket shown from the strut tower.



9. Release the spring clamp then unhook the crank case vent hose from the valve cover.



10. Release the spring clamp then remove the upper throttle body by-pass hose from the throttle body.

NOTE: Be sure the engine is cool before disconnecting the by-pass hose. Be sure to capture any coolant that is released from the by-pass hose.



11. Release the spring clamp and then disconnect the steel by-pass hose assembly from the bypass hose attached to the thermostat housing.

NOTE: Be sure to capture any coolant that is released from the by-pass hose.



12. Connect the remaining bypass hose from the thermostat housing to the throttle body and secure with the factory hose clamp.



13. Remove the bolt shown that secures the heater hose pipe to the thermostat housing.



14. Secure bracket number 083121 to the thermostat housing as shown with the provided hardware.



15. Install silicone hose number 084034 onto the throttle body and secure with the provided hose clamp.



16. Install the provided edge trim onto the heat shield as shown.

NOTE: Some trimming of the edge trim will be necessary.



17. Install the provided rubber mounted stud into the air box mounting bracket location as shown.



18. Install bracket number 083120 onto the ECM mounting bracket as shown.

NOTE: Be sure to place the provided spacer between ECU bracket and the K&N® bracket.



19. Install the heat shield and secure to the rubber mounted stud and bracket using the provided hardware.



20. Remove the two screws that secure the mass air sensor to the air box then remove the mass air sensor from the air box.



21. Install the mass air sensor into the intake tube and secure with the provided hardware.



22. Install the provided NPT vent fitting into the intake tube as shown.

NOTE: Plastic NPT fittings are easy to cross thread. Install the vent fitting "hand" tight, then turn it two complete turns with a wrench.



23. Install the K&N® intake tube through the heat shield, into the silicone hose at the throttle body and align with the tube mounting bracket previously installed. Align and then secure with the provided hose clamp and hardware.



24. Install the provided crank case vent hose onto the valve cover vent port and fitting onto the K&N® intake tube.



25. Install the K&N® filter and secure with provided hose clamp.

NOTE: Drycharger® air filter wrap; part # RC-4630DKDK is available to purchase separately.



26. Reconnect the mass air sensor electrical connection.



27. Reconnect the vehicle's negative battery cable. Double check to make sure everything is tight and properly positioned before starting the vehicle.

28. The C.A.R.B. exemption sticker, (attached), must be visible under the hood so that an emissions inspector can see it when the vehicle is required to be tested for emissions. California requires testing every two years, other states may vary.

29. It will be necessary for all K&N® high flow intake systems to be checked periodically for realignment, clearance and tightening of all connections. Failure to follow the above instructions or proper maintenance may void warranty.

ROAD TESTING:

1. Start the engine with the transmission in neutral or park, and the parking brake engaged. Listen for air leaks or odd noises. For air leaks secure hoses and connections. For odd noises, find cause and repair before proceeding. This kit will function identically to the factory system except for being louder and much more responsive.

2. Test drive the vehicle. Listen for odd noises or rattles and fix as necessary.

3. If road test is fine, you can now enjoy the added power and performance from your kit.

4. K&N Engineering, Inc., requires cleaning the intake system's air filter element every 100,000 miles. When used in dusty or off-road environments, our filters will require cleaning more often. We recommend that you visually inspect your filter once every 25,000 miles to determine if the screen is still visible. When the screen is no longer visible some place on the filter element, it is time to clean it. To clean and re-oil, purchase our filter Recharger® service kit, part number 99-5050 or 99-5000 and follow the easy instructions.