



PERFORMANCE EXHAUST SYSTEM



INSTALLATION INSTRUCTIONS

67-1515

JEEP

2018-19 Wrangler JL

V6-3.6L

NOTE: Fits 4 door models only

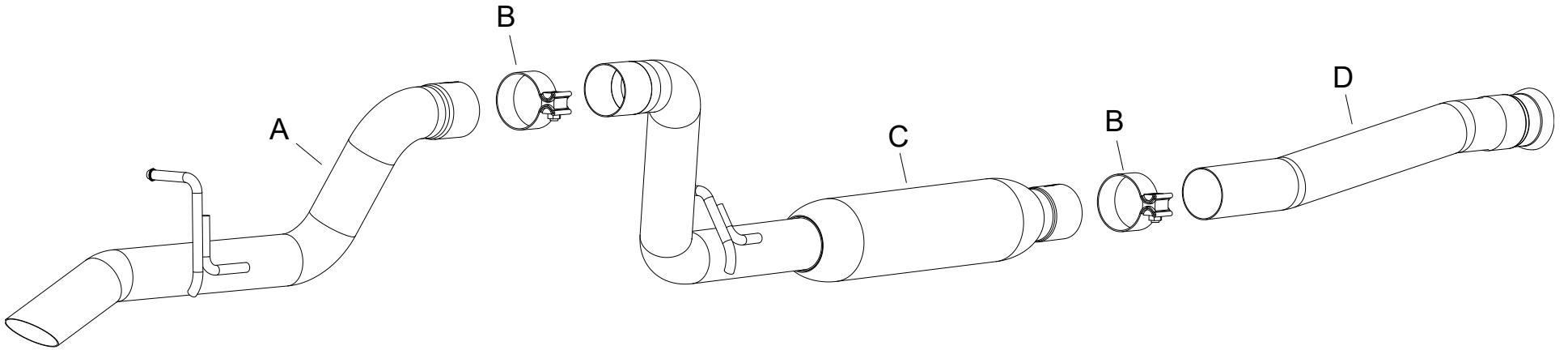

TOOLS NEEDED:

ratchet
 extension
 13mm socket
 15mm socket
 13mm wrench

PARTS LIST:

	Description	Qty.	Part #
A	TAILPIPE ASSY; JL	1	344083
B	2.5" TORCA CLAMP	2	RH-AS25
C	MIDPIPE ASSY; JL	1	344082
D	MIDPIPE FRONT; JL 4 DOOR	1	344099

TO START:

1. Turn off the ignition and allow engine and exhaust to cool to the touch.

WARNING: Exhaust components can be extremely hot after vehicle operation and can severely burn you.

Raise the vehicle to access the factory exhaust system with a lift or appropriate jack and properly positioned stands. It may be helpful to spray all existing hardware and hanger assemblies being removed with a penetrating oil or similar lubricant and allow to soak, especially if older and rusted.

WARNING: If working without a lift always use the correct jack points and lifting procedures specified by the vehicle manufacturer. Serious injury or death could occur if proper safety measures are not followed.



2. Loosen the clamp that secures the muffer pipe to the exhaust pipe.



3. Loosen and remove the two bolts that secure the driver side muffer hanger to the chassis.
NOTE: one bolt is not in view in this picture.



4. Loosen and remove the two bolts that secure the passenger side muffer hanger to the chassis.
NOTE: one bolt is not in view in this picture. Support the muffer assembly while removing the bolts as it may now swing and fall.



5. Using a twisting motion so the muffer pipe slides off the exhaust pipe, remove the muffer assembly from the vehicle.
NOTE: K&N Engineering, Inc., recommends that customers do not discard factory exhaust.



6. Remove the four bolts that secure the transfer case skid plate and the remove the skid plate from the vehicle.



7. Loosen the clamp the secures the exhaust mid pipe to the exhaust catalyst pipe.

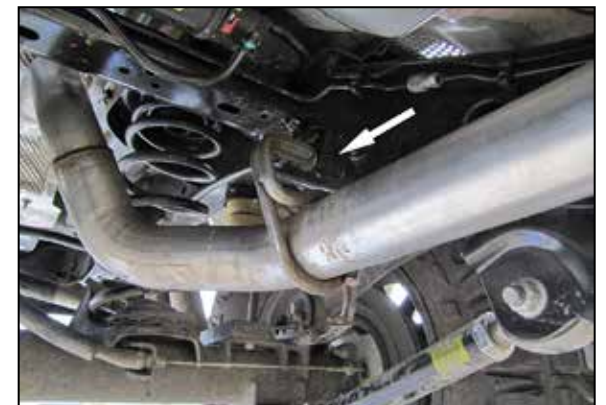

8. Disconnect the exhaust pipe hanger and then remove the exhaust pipe from the vehicle.
NOTE: Applying some lube to the mount post may aid in removal of the hanger.



9. Release the locking tab and then remove the factory clamp from the exhaust pipe.



10. Reinstall the transfer case skid plate and secure with the factory bolts.



11. Install the K&N® mid pipe to the factory catalyst pipe and secure with the factory clamp.

NOTE: Do not completely tighten the clamp at this time, all clamps should be left loosely installed until the complete system is installed and aligned.



12. Install the K&N® muffler onto the K&N® mid pipe and into the factory hanger.

NOTE: Do not completely tighten the clamp at this time, all clamps should be left loosely installed until the complete system is installed and aligned.



13. Remove the driver side muffler hanger from the stock muffler.

NOTE: if necessary, apply a small amount of lube to aid in the removal of the hanger.



14. Install the driver side muffler hanger onto the K&N® tail pipe hanger.



15. Install the K&N® tail pipe onto the K&N® exhaust pipe.



16. Check alignment and reposition as necessary. Once final position is satisfactory, tighten all band clamps from front to rear of vehicle.

NOTE: All band clamps should be torqued to 40-45 ft-lbs

17. Double check to make sure everything is tight and properly positioned before lowering the vehicle to the ground.

ROAD TESTING:

1. Start the engine with the transmission in neutral or park, and the parking brake engaged. Listen for exhaust leaks or odd noises. For exhaust leaks secure flanges and/or connections. For odd noises, find cause and repair before proceeding. This kit will function identically to the factory system except for being louder.
2. Test drive the vehicle. Listen for odd noises or rattles and fix as necessary.
3. If road test is fine, you can now enjoy the added power and performance from your exhaust system.