



AIRCHARGER®

HIGH-FLOW INTAKE KITS

INSTALLATION INSTRUCTIONS

63-6020
NISSAN
2017-18 Titan XD
V8-5.6L

TOOLS NEEDED:

- flat blade screw driver
- ratchet
- extension
- 10mm socket
- pliers
- 10mm wrench
- 3mm allen
- 4mm allen

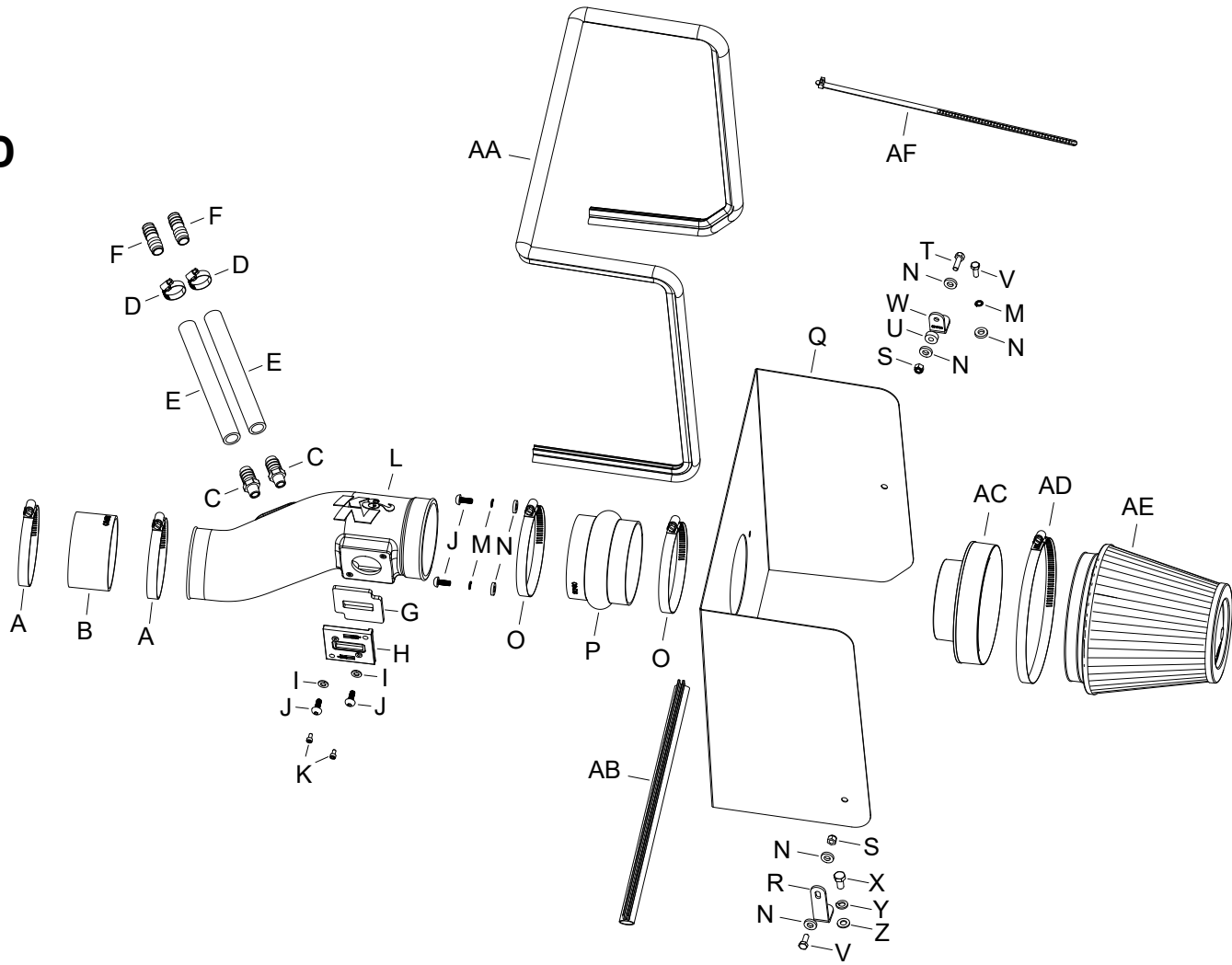

PARTS LIST:

Description	Qty.	Part #	Description	Qty.	Part #	Description	Qty.	Part #
A HOSE CLAMP #56	2	08620	K BOLT; M4-.7 X 8MM, ALLEN SS	2	07733	V BOLT; 6MM-1.00 X 16MM, SS	2	07812
B HOSE; 3.5"ID X 2"L	1	08698	L TUBE; FIPK 63-6020, ML	1	087376	W BRACKET; "L", 69-2521, SML	1	070066A
C FITTING; VENT STRT 5/8	2	08911-1	M WASHER, M6 SPLIT LOCK ZINC	3	1-3025	X BOLT; 8MM-1.25 X 16MM, HEX	1	07844
D HOSE CLAMP #10 MINI	2	08411	N WASHER; 1/4"ID X 5/8"OD	7	08275	Y WASHER, M8 SPLIT LOCK ZINC	1	1-3036
E HOSE; 5/8"ID X 7.5"L	2	084008	O HOSE CLAMP #64 STAINLESS	2	08645	Z WASHER; 8MM, FLAT, SS	1	08272
F VENT; STRT, 5/8"OD BARB	2	08048	P HOSE; HUMP 4"ID X 3"L	1	08418	AA EDGE TRIM; 3/4"BULB; TOP	1	102474
G GASKET; 57-2556, 3/16" PORON	1	09069	Q HEAT SHIELD; 63-6020, MILD	1	073264	AB EDGE TRIM; 3/4" BULB, TOP	1	102460
H ADAPTOR; MAF SENSOR	1	21515-1	R BRACKET; "L", 63-1015, TB/PC	1	070712A	AC ADAPTOR; 57-3058 #454	1	27300
I WASHER; 6MM FLAT, SS	2	08269	S NUT; 6MM NYLOCK, HEXHEAD	2	07512	AD HOSE CLAMP; #104	1	08697
J BOLT; M6 X 1.00 X 16MM, SS	4	07730	T BOLT; M6 X 1.00" X 20MM HEX	1	07795	AE 6"FLG, 7-1/2"B, 5"T, 6-1/2"H	1	RF-1042XD
			U SPACER: .625" OD X .250"ID	1	06555	AF TIE WRAP	1	21590

NOTE: FAILURE TO FOLLOW INSTALLATION INSTRUCTIONS AND NOT USING THE PROVIDED HARDWARE MAY DAMAGE THE INTAKE TUBE, THROTTLE BODY AND ENGINE.

TO START:

1. Turn off the ignition and disconnect the negative battery cable.
NOTE: Disconnecting the negative battery cable erases pre-programmed electronic memories. Write down all memory settings before disconnecting the negative battery cable. Some radios will require an anti-theft code to be entered after the battery is reconnected. The anti-theft code is typically supplied with your owner's manual. In the event your vehicles anti-theft code cannot be recovered, contact an authorized dealership to obtain your vehicles anti-theft code.



2. Disconnect the mass air sensor electrical connection and then unclip the harness from the air filter housing.



3. Lift up the engine cover and remove it from the vehicle.



4. Unclip the EVAP line and test port from the factory intake tube.



5. Loosen the hose clamp at the throttle body, unclip the upper air filter housing and disconnect the crank case vent lines from the intake tube. Remove the upper air filter housing, intake tube and factory air filter from the vehicle.



6. Remove the bolt that secures the lower air filter housing to the inner fender and then remove the lower air filter housing from the vehicle.
NOTE: K&N Engineering, Inc., recommends that customers do not discard factory air intake.



7. Install the provided mounting bracket (070066A) onto the heat shield using the provided hardware.



8. Install the provided mounting bracket (070712A) onto the heat shield using the provided hardware.



9. Install the filter adapter into the heat shield and secure with the provided hardware.



10. Install the provided edge trim onto the heat shield as shown.
NOTE: Some trimming of the edge trim will be necessary.



11. Remove the two-factory air filter housing mounting studs from the inner fender.



12. On 4 wheel drive models, secure the front differential vent line to the EVAP vent line.



13. Install the heat shield onto the inner fender and secure with the provided hardware.

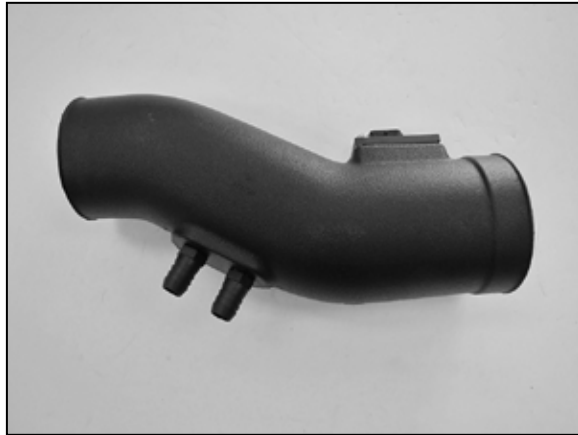

14. Install the two provided vent fittings into the K&N® intake tube as shown.
NOTE: Plastic NPT fittings are easy to cross thread. Install the vent fitting "hand" tight, then turn it two complete turns with a wrench.



15. Install the provided gasket onto the back of the mass air sensor adapter.
NOTE: The front side has mounting threads for the mass air sensor, do not mount gasket to this side.



16. Remove the mass air sensor from the factory housing and install it into the K&N® mass air sensor adapter and secure with the provided hardware.



17. Install the provided coupler hose (08698) onto the throttle body and secure with the provided hose clamp.



18. Install the mass air sensor assembly into the K&N® intake tube and secure with the provided hardware.

NOTE: Be sure to install the sensor with the opening towards the filter end of the tube.



19. Install the provided coupler (08761) onto the intake tube (Do not tighten). Install the intake tube into the coupler at the throttle body and align with the filter adapter. Secure the coupler hose and intake tube with the provided hose clamps.



20. Install the provided union fittings into the provided vent hose and secure with the provided hose clamps.



21. Install the vent fittings into the factory vent hoses and then onto the fittings installed into the K&N® intake tube.



22. Reconnect the mass air sensor electrical connection.



23. Install the K&N® air filter and secure with the provided hose clamp.



24. Reinstall the decorative engine cover.



25. Reconnect the vehicle's negative battery cable. Double check to make sure everything is tight and properly positioned before starting the vehicle.

26. It will be necessary for all K&N® high flow intake systems to be checked periodically for realignment, clearance and tightening of all connections. Failure to follow the above instructions or proper maintenance may void warranty.

ROAD TESTING:

1. Start the engine with the transmission in neutral or park, and the parking brake engaged. Listen for air leaks or odd noises. For air leaks secure hoses and connections. For odd noises, find cause and repair before proceeding. This kit will function identically to the factory system except for being louder and much more responsive.

2. Test drive the vehicle. Listen for odd noises or rattles and fix as necessary.

3. If road test is fine, you can now enjoy the added power and performance from your kit.

4. K&N Engineering, Inc., requires cleaning the intake system's air filter element every 100,000 miles. When used in dusty or off-road environments, our filters will require cleaning more often. We recommend that you visually inspect your filter once every 25,000 miles to determine if the screen is still visible. When the screen is no longer visible some place on the filter element, it is time to clean it. To clean and re-oil, purchase our filter Recharger® service kit, part number 99-5050 or 99-5000 and follow the easy instructions.