



# AIRCHARGER®

## HIGH-FLOW INTAKE KITS

### INSTALLATION INSTRUCTIONS

**63-6018**  
**INFINITY**  
**2011-14 QX56**  
**2015-17 QX80**  
**V8-5.6L**

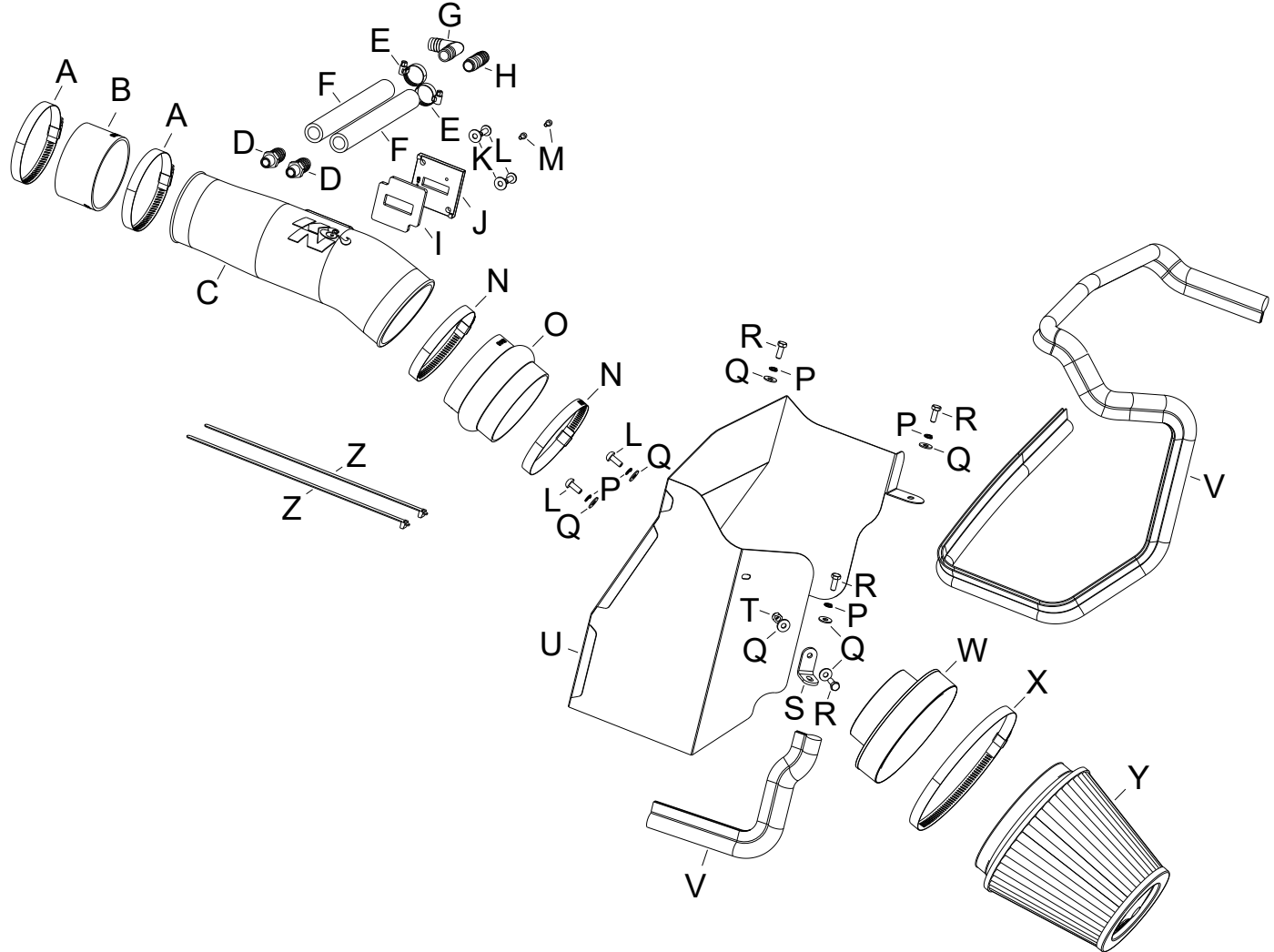

**TOOLS NEEDED:**

- ratchet
- extension
- 10mm socket
- flat blade screw driver
- 3/4" wrench
- 10mm wrench
- 4mm allen
- 3mm allen
- pliers

**PARTS LIST:**

Description	Qty.	Part #	Description	Qty.	Part #	Description	Qty.	Part #
A HOSE CLAMP #56	2	08620	J ADAPTOR; #420, NYLON 6/6 GF	1	21515	S BRACKET; 69-2521, "L", SML	1	070066
B HOSE; 3-1/2" ID X 2" L	1	08698	K WASHER; 6MM FLAT, SS	2	08269	T NUT; 6MM NYLOCK, HEXHEAD	1	07512
C INTAKE TUBE (LP)	1	087343A	L BOLT; M6 X 1.00 X 16MM, SS	4	07730	U HEAT SHIELD	1	073241
D VENT; STRT, 5/8 BARBED 1/4	2	08911-1	M BOLT; M4 - 0.07 8MM, A/H CAP	2	07733	V EDGE TRIM (75")	1	102460
E HOSE CLAMP #10 MINI	2	08411	N HOSE CLAMP #64 STAINLESS	2	08645	W ADAPTOR; 57-3058 #454	1	27300
F HOSE; 5/8"ID X 13"L	1	5-7013	O HOSE; 4" ID X 3" L HUMP REIN	1	08418	X HOSE CLAMP #104	1	08697
G VENT; 90 DEG, 5/8"HOSE, BLK	1	08072	P WASHER, M6 SPLIT LOCK ZINC	5	1-3025	Y FILTER CHARGER	1	RF-1042
H VENT; STRT, 5/8"HOSE - 5/8"	1	08048	Q WASHER; 1/4"ID X 5/8"OD	7	08275	Z CABLE TIES; 11" BLACK	2	21590
I GASKET; 57-2556, 3/16 PORON	1	09069	R BOLT; 6MM-1.00 X 16MM, SS	4	07812			

**NOTE: FAILURE TO FOLLOW INSTALLATION INSTRUCTIONS AND NOT USING THE PROVIDED HARDWARE MAY DAMAGE THE INTAKE TUBE, THROTTLE BODY AND ENGINE.**

**TO START:**

1. Turn off the ignition and disconnect the negative battery cable.  
**NOTE: Disconnecting the negative battery cable erases pre-programmed electronic memories. Write down all memory settings before disconnecting the negative battery cable. Some radios will require an anti-theft code to be entered after the battery is reconnected. The anti-theft code is typically supplied with your owner's manual. In the event your vehicles anti-theft code cannot be recovered, contact an authorized dealership to obtain your vehicles anti-theft code.**



2. Remove the two bolts that secure the decorative engine cover and then remove the cover from the engine.



3. Disconnect the mass air sensor electrical connection and unhook the harness from the air filter housing.



4. Release the spring clamps that secure the crank case breather hoses to the plenum chamber and then disconnect the crank case vent hoses. Unhook the EVAP canister from the plenum chamber.



5. Loosen the hose clamp that secures the intake tube to the throttle body.



6. Remove the three bolts that secure the air filter housing to the inner fender and then remove the complete intake system from the vehicle.  
**NOTE: On 4 wheel drive applications it is necessary to unhook the front differential vent hose from the air filter housing.**



7. Install the filter adapter into the heat shield and secure with the provided hardware.



8. Install the mounting bracket (070066) onto the heat shield using the provided hardware.



9. Cut the provided edge trim into two sections, one section will be 11" long and the other will be 63-1/2" long.

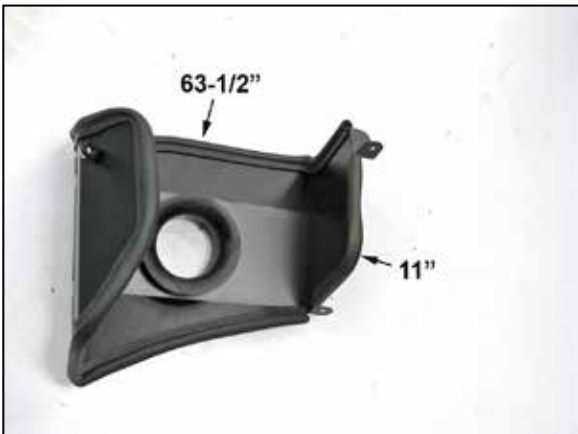

10. Install the edge trim onto the heat shield as shown.



11. Install the K&N® air filter onto the filter adapter and secure with the provided hose clamp.  
**NOTE: Drycharger® air filter wrap; part # RF-1042DK is available to purchase separately.**



12. Install the heat shield assembly into the vehicle and secure it to the factory air filter housing mounting locations using the provided hardware.



13. Install the provided coupler hose (08698) onto the throttle body and secure with the provided hose clamp.



14. Install the provided hump coupler (08418) onto the filter adapter and secure with the provided hose clamp.



15. Install the two provided NPT vent fittings into the K&N® intake tube as shown.  
**NOTE: Plastic NPT fittings are easy to cross thread. Install the vent fitting "hand" tight, then turn it two complete turns with a wrench.**



16. Install the provided gasket onto the mass air sensor adapter as shown.



17. Remove the mass air sensor from the factory air filter housing.



18. Install the mass air sensor into the K&N® adapter and secure with the provided hardware.



19. Install the mass air sensor assembly into the K&N® intake tube so that the opening in the sensor is towards the inlet end of the tube and then secure it with the provided hardware.



20. Install the K&N® intake tube into the hump coupler and then into the coupler at the throttle body, adjust the tube for best fit and then secure with the provided hose clamps.



21. Cut the provided crank case vent hose into two sections, one section will be 5" long and the other will be 6-1/2" long.



22. Install the provided union fittings into the vent hoses as shown and secure with the provided clamps. The 90° fitting will be installed into the 5" long hose.



23. Install the vent hose assemblies into the factory vent hoses as shown; secure the factory vent hoses to the unions with the factory spring clamps. Connect the open ends of the hoses to the fittings installed into the K&N® intake tube.



24. Reconnect the mass air sensor electrical connection.



25. On 4 wheel drive vehicles, using one of the provided tie wraps secure the front differential breather to the EVAP lines.



26. Using one of the provided tie wraps, secure the EVAP vent line to the crank case vent lines.



27. Install the decorative engine cover and secure with the factory hardware.



28. Reconnect the vehicle's negative battery cable. Double check to make sure everything is tight and properly positioned before starting the vehicle.

29. It will be necessary for all K&N® high flow intake systems to be checked periodically for realignment, clearance and tightening of all connections. Failure to follow the above instructions or proper maintenance may void warranty.

#### ROAD TESTING:

1. Start the engine with the transmission in neutral or park, and the parking brake engaged. Listen for air leaks or odd noises. For air leaks secure hoses and connections. For odd noises, find cause and repair before proceeding. This kit will function identically to the factory system except for being louder and much more responsive.

2. Test drive the vehicle. Listen for odd noises or rattles and fix as necessary.

3. If road test is fine, you can now enjoy the added power and performance from your kit.

4. K&N Engineering, Inc., requires cleaning the intake system's air filter element every 100,000 miles. When used in dusty or off-road environments, our filters will require cleaning more often. We recommend that you visually inspect your filter once every 25,000 miles to determine if the screen is still visible. When the screen is no longer visible some place on the filter element, it is time to clean it. To clean and re-oil, purchase our filter Recharger® service kit, part number 99-5050 or 99-5000 and follow the easy instructions.