



AIRCHARGER®

HIGH-FLOW INTAKE KITS

INSTALLATION INSTRUCTIONS

63-3516

HONDA

2016-17 Civic

L4-1.5L Turbo

TOOLS NEEDED:

- flat blade screw driver
- phillips screw driver
- ratchet
- extension
- 10mm socket
- 8mm socket
- 4mm hex key
- 3mm hex key
- side cutters

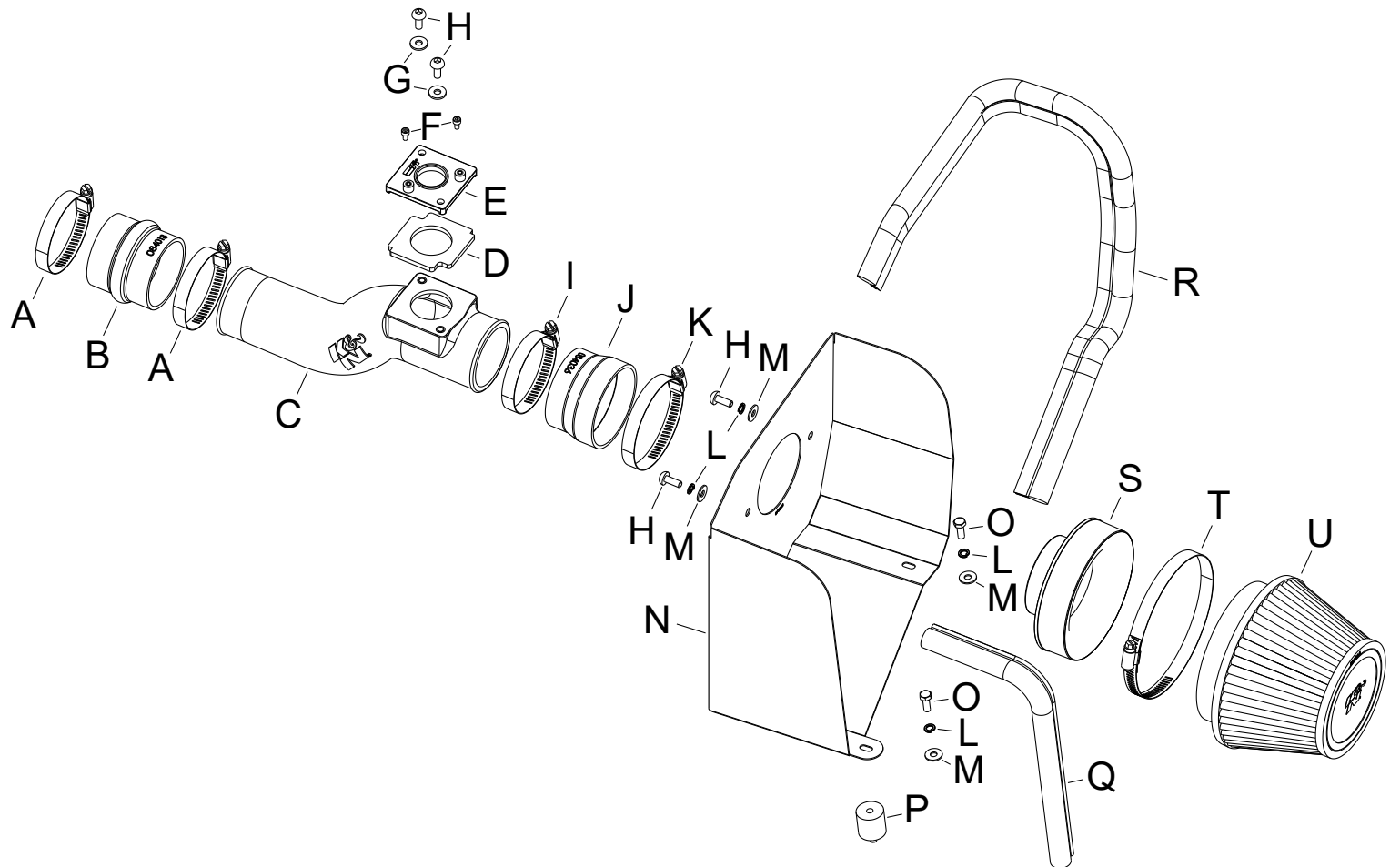

PARTS LIST:

Description	Qty.	Part #	Description	Qty.	Part #	Description	Qty.	Part #
A HOSE CLAMP #40	2	08554	H BOLT; M6 X 1.00 X 16MM, SS	4	07730	O BOLT; 6MM-1.00 X 16MM, SS	2	07812
B HOSE; 2-1/2" ID X 2-1/2" L	1	084018	I HOSE CLAMP #44 STAINLESS	1	08560	P STUD; RUBBER MOUNT, M6	1	02033
C INTAKE TUBE (LI)	1	087340A	J HOSE; 3" TO 2-3/4" ID X 2" L	1	084036	Q EDGE TRIM (14")	1	102478
D GASKET; 57-1003, 3/16 PORON	1	09074	K HOSE CLAMP #48	1	08601	R EDGE TRIM (30")	1	102489
E ADAPTER; MAF SENSOR	1	088022	L WASHER, M6 SPLIT LOCK ZINC	4	1-3025	S ADAPTER; FILTER, 3.0"OD	1	21569
F BOLT; M4 - 0.07 8MM, A/H CAP	2	07733	M WASHER; 1/4"ID X 5/8"OD	4	08275	T HOSE CLAMP #80	1	08694
G WASHER; 6MM FLAT, SS	2	08269	N HEAT SHIELD	1	073235	U FILTER CHARGER	1	RU-5163

NOTE: FAILURE TO FOLLOW INSTALLATION INSTRUCTIONS AND NOT USING THE PROVIDED HARDWARE MAY DAMAGE THE INTAKE TUBE, THROTTLE BODY AND ENGINE.

TO START:

1. Turn off the ignition and disconnect the negative battery cable.

NOTE: Disconnecting the negative battery cable erases pre-programmed electronic memories. Write down all memory settings before disconnecting the negative battery cable. Some radios will require an anti-theft code to be entered after the battery is reconnected. The anti-theft code is typically supplied with your owner's manual. In the event your vehicles anti-theft code cannot be recovered, contact an authorized dealership to obtain your vehicles anti-theft code.



2. Disconnect the Mass air sensor connection and unhook the wiring harness from the air filter housing.

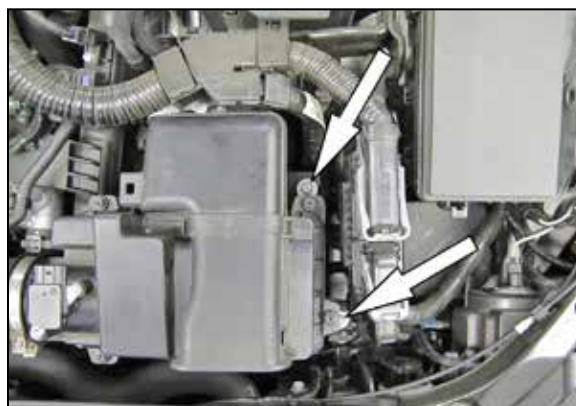

3. Loosen the two bolts securing the air filter housing to the mount bracket and inner fender.



4. Loosen the hose clamp that secures the intake hose to the turbo inlet pipe and then remove the air filter housing and hose assembly.
NOTE: K&N Engineering, Inc., recommends that customers do not discard factory air intake.



5. Install the provided rubber mounted stud onto the inner fender air filter housing mounting location.

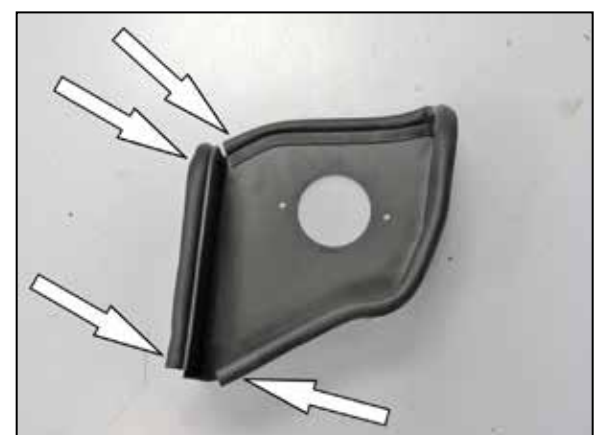

6. Install the provided edge trim onto the heat shield as shown.
NOTE: some trimming of the edge trim will be necessary.

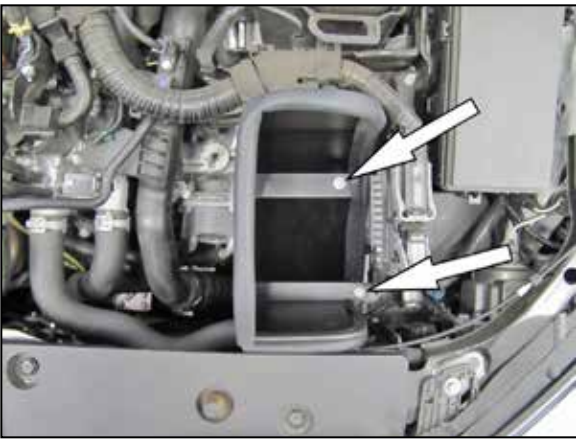

7. Install the heat shield onto the rubber mounted stud and air filter housing mounting bracket and secure with the provided hardware.



8. Install the filter adapter into the K&N® air filter and secure with the provided hardware.
NOTE: Drycharger® air filter wrap; part # RU-5163DK is available to purchase separately.



9. Install the filter assembly into the heat shield and secure with the provided hardware.



10. Install the coupling hose (084018) onto the turbo inlet pipe and secure with the provided hose clamp.



11. Install the coupling hose (084036) onto the filter adapter and secure with the provided hose clamp.



12. Install the provided gasket onto the mass air sensor adapter.



13. Remove the mass air sensor from the factory air filter housing.



14. Install the mass air sensor into the provided adapter and secure with the provided hardware.



15. Install the mass air sensor assembly into the K&N intake tube and secure with the provided hardware.
NOTE: Be sure to install the sensor assembly in the correct direction, the long side of the sensor is to face the air filter end of the intake tube.



16. Install the K&N® intake tube assembly into the coupling hoses, adjust the tube for best fit and then secure with the provided hose clamps.



17. Reconnect the mass air sensor electrical connection.



18. Reconnect the vehicle's negative battery cable. Double check to make sure everything is tight and properly positioned before starting the vehicle.

19. It will be necessary for all K&N® high flow intake systems to be checked periodically for realignment, clearance and tightening of all connections. Failure to follow the above instructions or proper maintenance may void warranty.

ROAD TESTING:

1. Start the engine with the transmission in neutral or park, and the parking brake engaged. Listen for air leaks or odd noises. For air leaks secure hoses and connections. For odd noises, find cause and repair before proceeding. This kit will function identically to the factory system except for being louder and much more responsive.

2. Test drive the vehicle. Listen for odd noises or rattles and fix as necessary.

3. If road test is fine, you can now enjoy the added power and performance from your kit.

4. K&N Engineering, Inc., requires cleaning the intake system's air filter element every 100,000 miles. When used in dusty or off-road environments, our filters will require cleaning more often. We recommend that you visually inspect your filter once every 25,000 miles to determine if the screen is still visible. When the screen is no longer visible some place on the filter element, it is time to clean it. To clean and re-oil, purchase our filter Recharger® service kit, part number 99-5050 or 99-5000 and follow the easy instructions.