



AIRCHARGER®

HIGH-FLOW INTAKE KITS

NOT LEGAL FOR SALE OR USE ON ANY POLLUTION CONTROLLED MOTOR VEHICLE IN CALIFORNIA OR STATES ADOPTING CALIFORNIA EMISSION PROCEDURES.

INSTALLATION INSTRUCTIONS

63-3120 CHEVROLET 2020-21 CORVETTE V8-6.2L

PARTS LIST:

Description	Qty.	Part #
A HEAT BARRIER; LT SIDE	1	074527
B HEAT BARRIER; RT SIDE	1	074526
C HEAT BARRIER; LT LOWER	1	074531
D HEAT BARRIER; RT LOWER	1	074532
E HEAT SHIELD; LT SIDE	1	074525
F HEAT SHIELD; RT SIDE	1	074524
G HOSE CLAMP; #64 SS	2	08645KA
H HOSE; 4" TO 3-13/16"ID	1	08618
I INTAKE TUBE (PG)	1	087511
J FITTING; 3/8"NPT	1	82639
K BOLT; M4-.7 X 8MM	2	07733
L WASHER; 6MM FLAT	8	08269
M WASHER; M6 SPLIT LOCK	8	1-3025
N BOLT; M6 X 1.00 X 16MM	8	07730
O BRACKET; H/S LT SIDE	1	064371
P BRACKET; H/S RT SIDE	1	064370
Q SCREW; M4-.7 X 12	2	07726
R WASHER; 4MM FLAT	2	08278
S NUT; 4MM NYLOCK	2	07501
T AIR FILTER	1	RP-6103
U EDGE TRIM 61"L	2	102492A
V CABLE TIES 11" BLACK	2	21590
W CABLE TIE 6"	2	21595
X HOSE CLAMP #72	1	08671KA

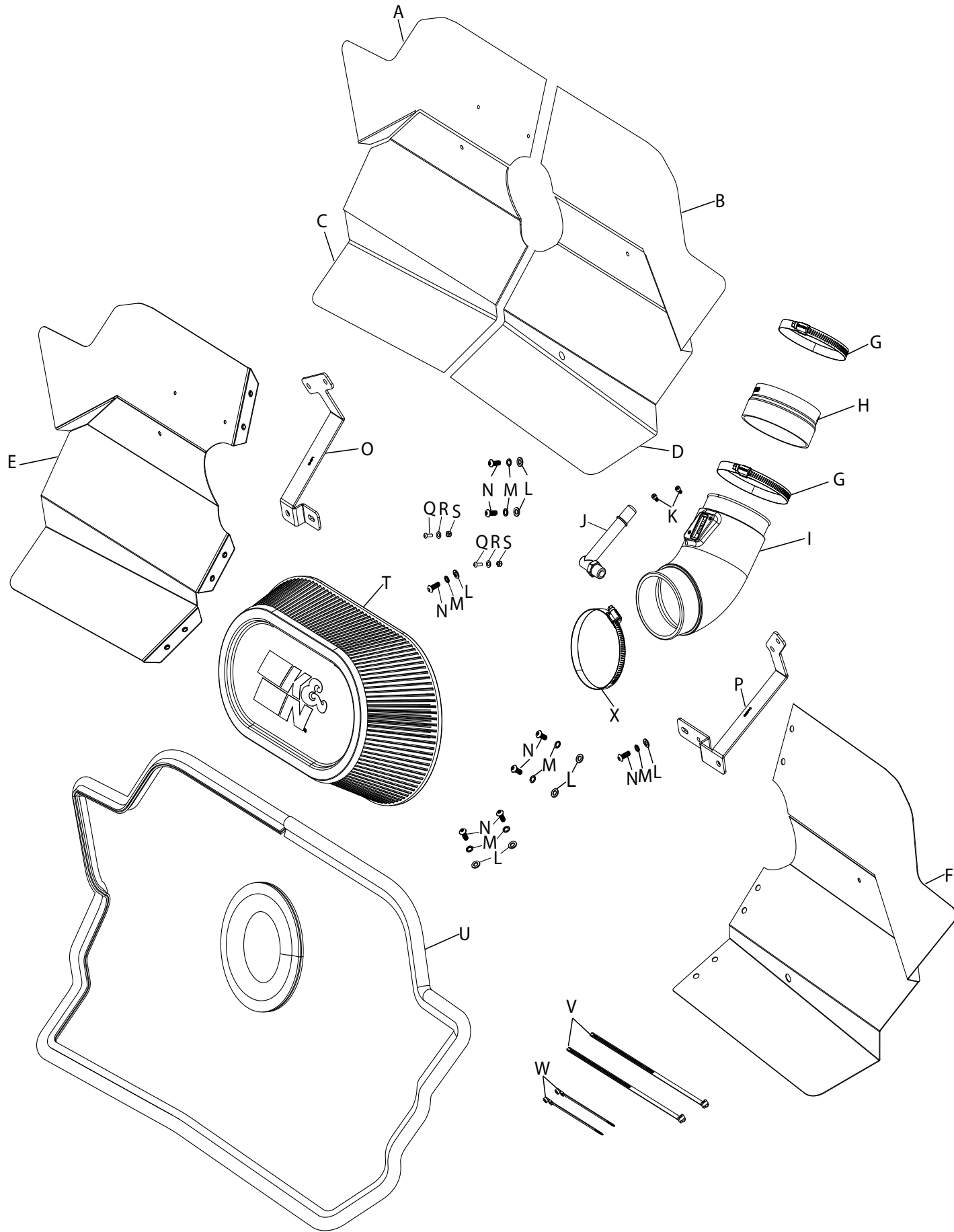

TOOLS NEEDED:

- Flat blade screw drive
- Ratchet
- Extension
- wobble joint
- 10mm socket
- 7mm socket
- 4mm allen
- 3mm allen
- 2.5mm allen
- Side cutters,
- Panel popper tool
- or similar

NOTE: FAILURE TO FOLLOW INSTALLATION INSTRUCTIONS AND NOT USING THE PROVIDED HARDWARE MAY DAMAGE THE INTAKE TUBE, THROTTLE BODY AND ENGINE.

TO START:

1. Turn off the ignition and disconnect the negative battery cable.
NOTE: Disconnecting the negative battery cable erases pre-programmed electronic memories. Write down all memory settings before disconnecting the negative battery cable. Some radios will require an anti-theft code to be entered after the battery is reconnected. The anti-theft code is typically supplied with your owner's manual. In the event your vehicles anti-theft code cannot be recovered, contact an authorized dealership to obtain your vehicles anti-theft code.



2. Open the rear hatch and locate the two roof stowage mounts. Remove the bolts that secure the stowage mounts and set the mounts aside. Remove the two wing nuts at the bottom of the compartment that secure the carpet.



3. Remove the carpet and set aside.



4. Remove the nineteen bolts that secure the air filter access panel and then remove the panel and set aside.



5. Remove the eight bolts that secure the two fresh air intake ducts and then remove the two ducts.



6. Disconnect the air temperature sensor electrical connection.



7. Remove the two bolts that secure the bottom of the air box.



8. Disconnect the mass air sensor electrical connection.



9. Disconnect the transmission vent canister from the air filter housing.



10. Remove the bolt that secures the passenger side of the air box to the transmission.



11. Cut the one time use clamp that secures the CCV hose and then disconnect the CCV hose from the factory intake tube. Loosen the hose clamp that secures the intake tube to the throttle body.



12. Remove the driver's side lower air box mounting bolt.



13. Disconnect the wiring harness's that attach to the rear of the air filter assembly.



14. Pull the air filter assembly back slightly to expose "F" antenna at the top of the housing. Disconnect the electrical connection of the "F" antenna and then remove the air filter assembly from the vehicle. Remove the two fresh air duct extensions from the vehicle.



15. Install the two-heat shield mounting brackets to the chassis cross member using the four-air box mounting bolts.



16. If the Transmission reservoir mount broke during disassembly, Install the mounting tree tie wrap onto the reservoir as shown.



17. Attach the transmission vent reservoir and o2 wiring harness to the heat shield mounting brackets.



18. Install the coupler onto the throttle body and secure with the provided hose clamp.



19. Cut the two provided edge trim into sections as shown.



20. Install the provided edge trim onto the two heat shield halves as shown.



21. Peel the backing off the heat barrier and then apply the barrier to the engine side of the heat shield as shown. After the heat barrier is installed, use a knife or similar tool to cut out all of the mounting holes in the heat shield through the heat barrier.

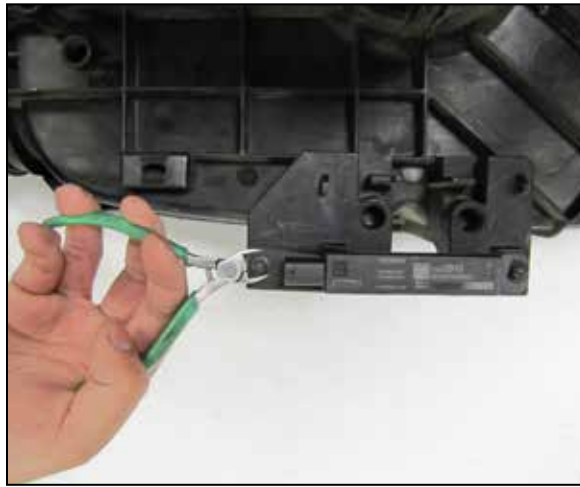

22. Cut the sonic welds that secure the "F" antenna to the air filter housing and then remove the antenna from the housing.



23. Remove the air temperature sensor from the air filter housing.



24. Install the "F" antenna to the engine side of the driver's side heat shield assembly using the provided hardware with the button head of the bolt on the filter side of the heat shield.



25. Install the drivers side heat shield assembly and align with the mounting bracket. Secure the heat shield with the provided hardware. Reconnect the "F" antenna electrical connection.



26. Remove the mass air sensor from the factory air filter housing and install it into the K&N intake tube using the provided hardware.



27. Install the CCV fitting into the K&N intake tube as shown.



28. Set the intake tube into position but do not secure. Install the passenger side heat shield and align with the mounting bracket. Install all of the mounting hardware loosely before tightening. Reconnect the temperature sensor electrical connection.



29. Push the intake tube towards the rear of the vehicle, install the filter onto the tube and secure with the provided hose clamp. Be sure to check the alignment before tightening the hose clamp, when the intake tube is installed the filter should sit horizontal.



30. Insert the intake tube into the coupler at the throttle body and secure with the provided hose clamp. Be sure the tube and filter are aligned and straight before tightening the holes clamps.



31. Reconnect the mass air sensor electrical connection.



32. Reinstall the filter access panel, carpet and top stowage mounts using the factory hardware.

33. Reconnect the vehicle's negative battery cable. Double check to make sure everything is tight and properly positioned before starting the vehicle.

34. It will be necessary for all K&N® high flow intake systems to be checked periodically for realignment, clearance and tightening of all connections. Failure to follow the above instructions or proper maintenance may void warranty.

ROAD TESTING:

1. Start the engine with the transmission in neutral or park, and the parking brake engaged. Listen for air leaks or odd noises. For air leaks secure hoses and connections. For odd noises, find cause and repair before proceeding. This kit will function identically to the factory system except for being louder and much more responsive.
2. Test drive the vehicle. Listen for odd noises or rattles and fix as necessary.
3. If road test is fine, you can now enjoy the added power and performance from your kit.
4. K&N Engineering, Inc., requires cleaning the intake system's air filter element every 100,000 miles. When used in dusty or off-road environments, our filters will require cleaning more often. We recommend that you visually inspect your filter once every 25,000 miles to determine if the screen is still visible. When the screen is no longer visible some place on the filter element, it is time to clean it. To clean and re-oil, purchase our filter Recharger® service kit, part number 99-5050 or 99-5000 and follow the easy instructions.

NOT LEGAL FOR SALE OR USE ON ANY POLLUTION CONTROLLED MOTOR VEHICLE IN CALIFORNIA OR STATES ADOPTING CALIFORNIA EMISSION PROCEDURES.