



# AIRCHARGER®

## HIGH-FLOW INTAKE KITS

### INSTALLATION INSTRUCTIONS

#### 63-3106 CHEVROLET 2016-18 Malibu L4-1.5L Turbo

#### TOOLS NEEDED:

ratchet  
extension  
13mm socket  
10mm socket  
3mm allen  
4mm allen  
t20 torx  
flat blade screw driver  
10mm wrench

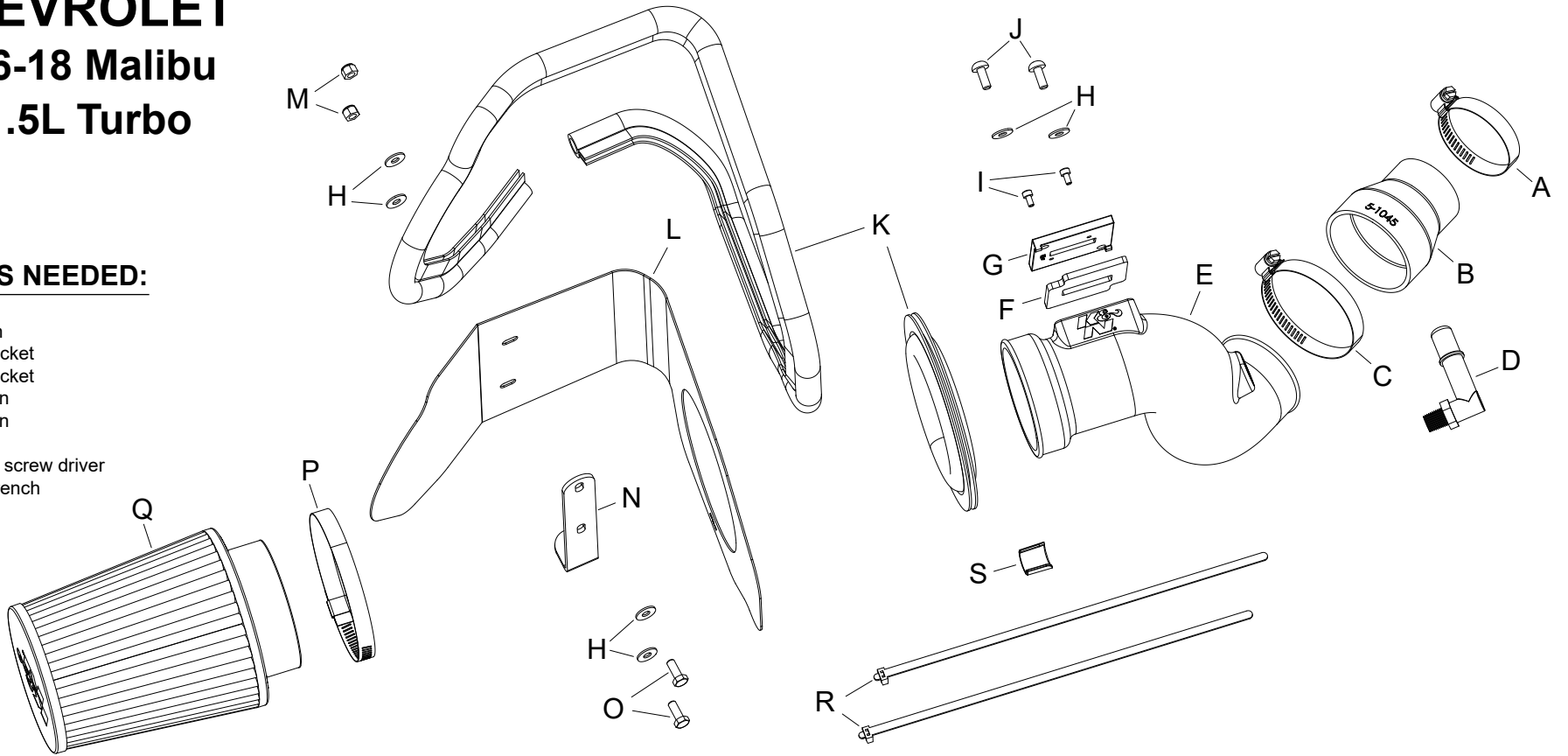

#### PARTS LIST:

Description	Qty.	Part #	Description	Qty.	Part #	Description	Qty.	Part #
A HOSE CLAMP #32	1	08507	G ADAPTOR; 57-2556, NYLON 6/6	1	21515	M NUT; 6MM NYLOCK, HEXHEAD	2	07512
B HOSE; 2.75" TO 2"ID X 3"L	1	5-1045	H WASHER; 6MM FLAT, SS	6	08269	N BRACKET; 63-3091, "L", TB/PC	1	064337
C HOSE CLAMP #44 STAINLESS	1	08560	I BOLT; M4 - 0.07 8MM, A/H CAP	2	07733	O BOLT; 6MM-1.00 X 16MM, SS	2	07812
D VENT; 90°D, 1/4"NPT QUICK	1	088028	J BOLT; M6 X 1.00 X 16MM, SS	2	07730	P HOSE CLAMP; #60	1	08624
E INTAKE TUBE	1	087367A	K EDGE TRIM (66")	1	102472	Q FILTER CHARGER	1	RC-4630
F GASKET; 57-2556, 3/16" PORON	1	09069	L HEAT SHIELD	1	073240	R CABLE TIES; 11" BLACK	2	21590
						S QUICK DISCONNECT TOOL	1	088027

**NOTE: FAILURE TO FOLLOW INSTALLATION INSTRUCTIONS AND NOT USING THE PROVIDED HARDWARE MAY DAMAGE THE INTAKE TUBE, THROTTLE BODY AND ENGINE.**

#### TO START:

1. Turn off the ignition and disconnect the negative battery cable.

**NOTE: Disconnecting the negative battery cable erases pre-programmed electronic memories. Write down all memory settings before disconnecting the negative battery cable. Some radios will require an anti-theft code to be entered after the battery is reconnected. The anti-theft code is typically supplied with your owner's manual. In the event your vehicles anti-theft code cannot be recovered, contact an authorized dealership to obtain your vehicles anti-theft code.**



2. Release the red locking tab and then disconnect the mass air sensor electrical connection. Unhook the wiring harness from the air filter housing and set to the side.



3. Snap the provided quick release tool onto the CCV tube, then push it up to unlock the CCV quick release connector and disconnect the CCV hose from the intake tube.



4. Loosen the hose clamp that secures the intake tube to the turbo inlet then disconnect the tube from the turbo. Lift the intake assembly up to dislodge it from the mounting grommets and then remove the complete intake system from the vehicle.

**NOTE: K&N Engineering, Inc., recommends that customers do not discard factory air intake.**



5. Install the provided coupler (5-1045) onto the turbo inlet and secure with the provided hose clamp.



6. Install the provided "L" bracket onto the heat shield as shown using the provided hardware.



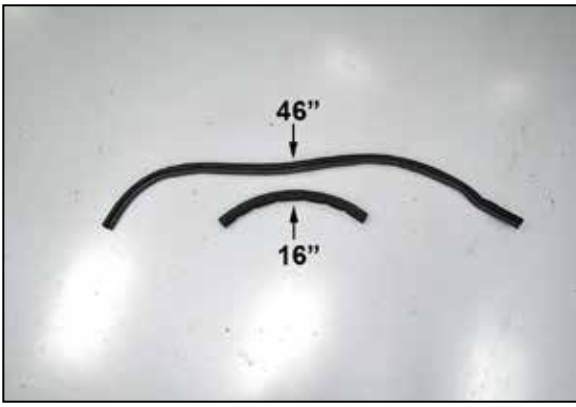

7. Cut the provided edge trim into two sections of 46" and 16".



8. Install the 16" section into the heat shield and the 46" section around the heat shield as shown.



9. Remove the bolt shown from the fender brace.  
**NOTE: This bolt will be reused in the next step.**



10. Install the heat shield into position and secure with the bolt removed in the previous step.



11. Remove the mass air sensor from the factory air filter housing. Install the sensor and provided gasket onto the K&N® filter adapter as shown.

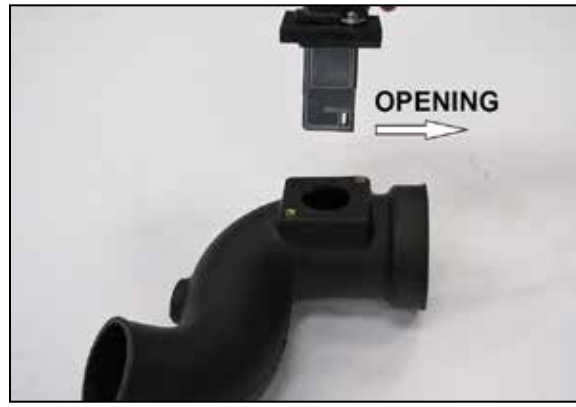

12. Install the mass air sensor assembly into the K&N® intake tube and secure with the provided hardware.

**NOTE: Be sure to install the sensor with the opening towards the filter end of the tube.**



13. Install the provided quick disconnect fitting into the K&N® intake tube as shown.



14. Install the K&N® intake tube assembly through the heat shield and then into the coupler on the turbo. Adjust the tube and heat shield for best fit and then secure the hose clamp and heat shield bolt.



15. Connect the CCV hose to the quick disconnect fitting installed into the K&N® intake tube.



16. Connect the mass air sensor electrical connection.



17. Install the K&N® air filter and secure with the provided hose clamp.

**NOTE: Drycharger® air filter wrap; part # RC-4630DK is available to purchase separately. To learn more about Drycharger® filter wraps or look up color availability please visit <http://www.knfilters.com>.**



18. Reconnect the vehicle's negative battery cable. Double check to make sure everything is tight and properly positioned before starting the vehicle.

19. It will be necessary for all K&N® high flow intake systems to be checked periodically for realignment, clearance and tightening of all connections. Failure to follow the above instructions or proper maintenance may void warranty.

#### ROAD TESTING:

1. Start the engine with the transmission in neutral or park, and the parking brake engaged. Listen for air leaks or odd noises. For air leaks secure hoses and connections. For odd noises, find cause and repair before proceeding. This kit will function identically to the factory system except for being louder and much more responsive.

2. Test drive the vehicle. Listen for odd noises or rattles and fix as necessary.

3. If road test is fine, you can now enjoy the added power and performance from your kit.

4. K&N Engineering, Inc., requires cleaning the intake system's air filter element every 100,000 miles. When used in dusty or off-road environments, our filters will require cleaning more often. We recommend that you visually inspect your filter once every 25,000 miles to determine if the screen is still visible. When the screen is no longer visible some place on the filter element, it is time to clean it. To clean and re-oil, purchase our filter Recharger® service kit, part number 99-5050 or 99-5000 and follow the easy instructions.