



AIRCHARGER®

HIGH-FLOW INTAKE KITS

NOT LEGAL FOR SALE OR USE ON ANY POLLUTION CONTROLLED MOTOR VEHICLE IN CALIFORNIA OR STATES ADOPTING CALIFORNIA EMISSION PROCEDURES.
See knfilters.com for CARB status on each part for a specific vehicle

INSTALLATION INSTRUCTIONS

63-2617

FORD

2021-22 F150 Raptor

V6-2.7L / 3.5L Ecoboost

V6-3.5L Powerboost

TOOLS NEEDED:

- ratchet
- extension
- 7mm socket
- 8mm socket
- 10mm socket
- 13mm socket
- flathead screw driver

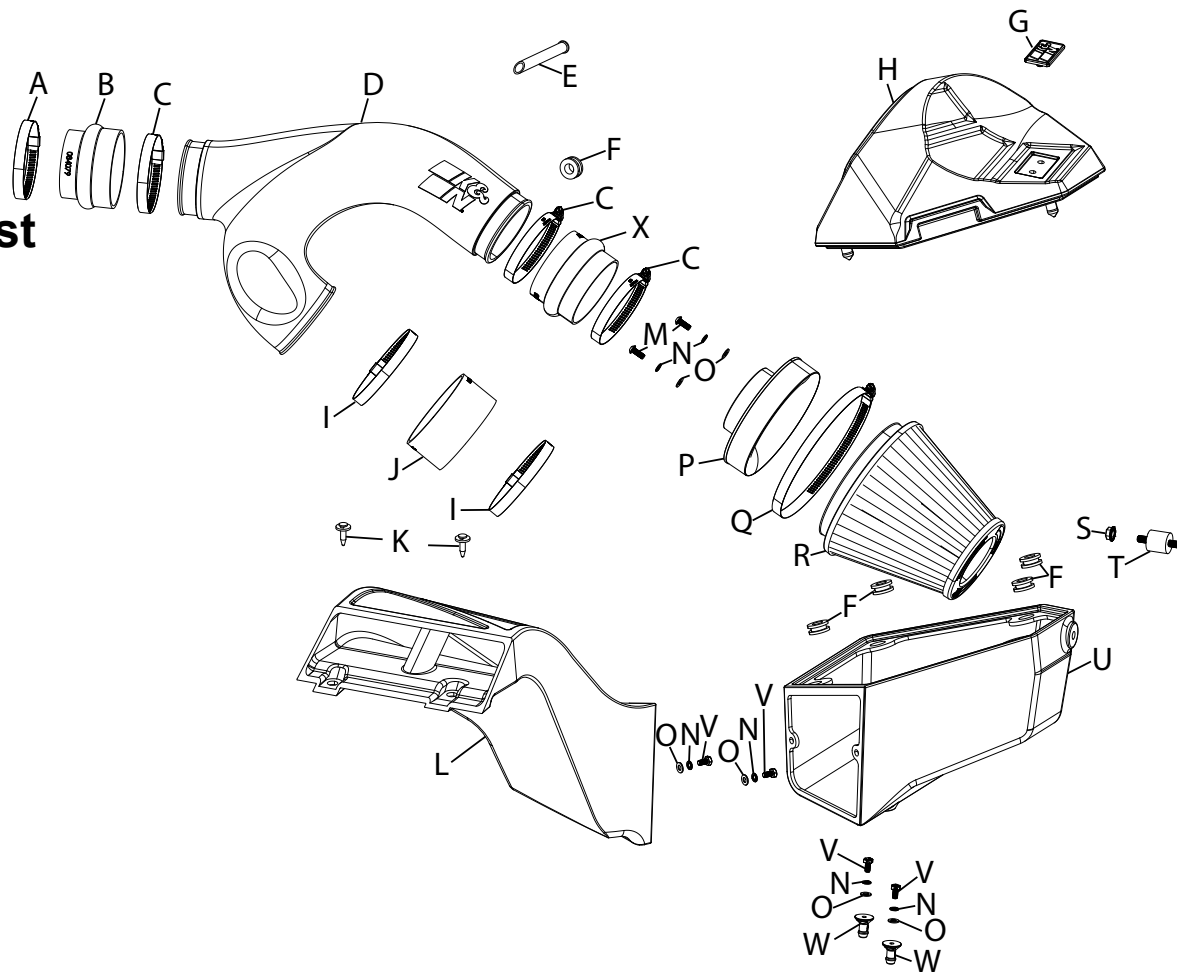

PARTS LIST:

Description	Qty.	Part #	Description	Qty.	Part #	Description	Qty.	Part #
A HOSE CLAMP; #48	1	08601	I HOSE CLAMP; #64 STAINLESS	2	08645	Q HOSE CLAMP; #104	1	08697
B HOSE; HUMP 3.5" TO 3"ID	1	084079	J HOSE; 4"ID X 2"L	1	08761	R AIR FILTER	1	RU-1042
C HOSE CLAMP; #56	3	08620	K CLIP; RETAINER BODY	2	KITRETCLIP02	S NUT; M8 HEX	1	444.460.08
D TUBE; AIR CHARGER (PT)	1	087524	L AIR DUCT; (PO)	1	087519	T MOUNT; RUBBER 1" X 8MM	1	1228560
E INSERT, PCV	1	7-284	M BOLT; M6 X 1 X16MM	2	07730	U AIRBOX; (MJ)	1	087426A
F GROMMET; 1"OD, 1/2"ID	5	08064	N WASHER; M6 SPLIT LOCK	6	1-3025	V BOLT; M6-1 X 16MM	4	07812
G BADGE; PASTIC, SNAP-IN	1	088096	O WASHER; 6MM FLAT	6	08269	W MOUNT; PLASTIC AIRBOX	2	8-186-1
H LID; (PN)	1	087518	P ADAPTER; 6" FILTER	1	21512-1	X HOSE; HUMP 3.5"ID X 2.5"L	1	08699

If you need any assistance please call 1-800-858-3333 to speak with a representative in our Customer Service Center before returning the product.

NOTE: FAILURE TO FOLLOW INSTALLATION INSTRUCTIONS AND NOT USING THE PROVIDED HARDWARE MAY DAMAGE THE INTAKE TUBE, THROTTLE BODY AND ENGINE.

TO START:

1. Turn off the ignition and disconnect the negative battery cable.
NOTE: Disconnecting the negative battery cable erases pre-programmed electronic memories. Write down all memory settings before disconnecting the negative battery cable. Some radios will require an anti-theft code to be entered after the battery is reconnected. The anti-theft code is typically supplied with your owner's manual. In the event your vehicles anti-theft code cannot be recovered, contact an authorized dealership to obtain your vehicles anti-theft code.



2. Loosen the three hose clamps that secure the intake tube.

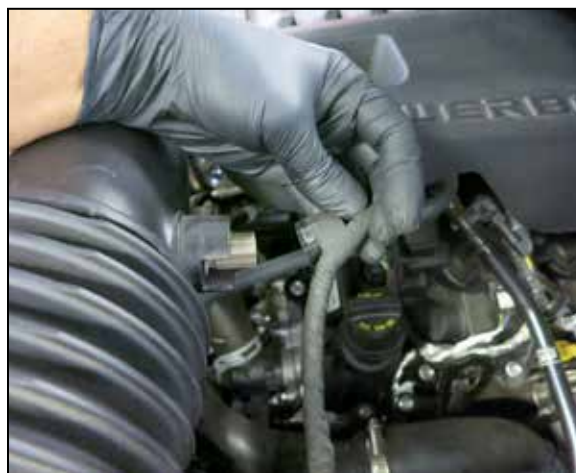

3. Disconnect the IAT sensor electrical connection.



4. Release the two clips that secure the upper air filter housing to the lower air filter housing.



5. Lift the upper air filter housing and intake tube up and out of the engine compartment.



6. Unhook the IAT sensor wiring harness from the lower air filter housing.



7. Remove the bolt that secures the lower air filter housing to the inner fender.

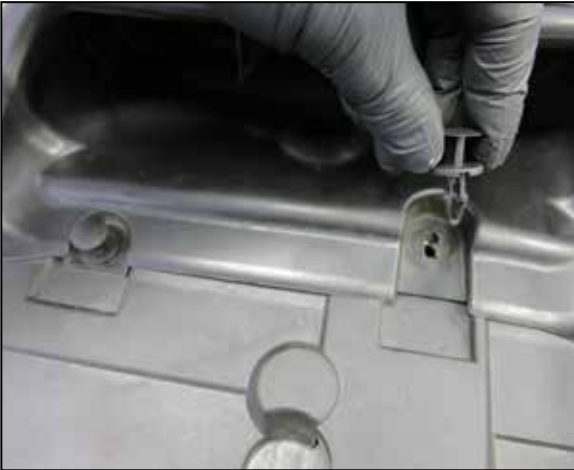

8. Remove the two push-clips that secure the fresh air intake duct to the core support.



9. Lift and remove the lower air filter housing/fresh air intake duct from the vehicle.



10. Release the locking tab and then twist the IAT sensor counterclockwise direction while pulling outwards to remove the sensor. **NOTE: The IAT sensor is very fragile, be careful while removing to prevent possible damage.**



11. Remove the O-ring from the IAT sensor. Install the provided grommet and the IAT sensor into the K&N intake tube.

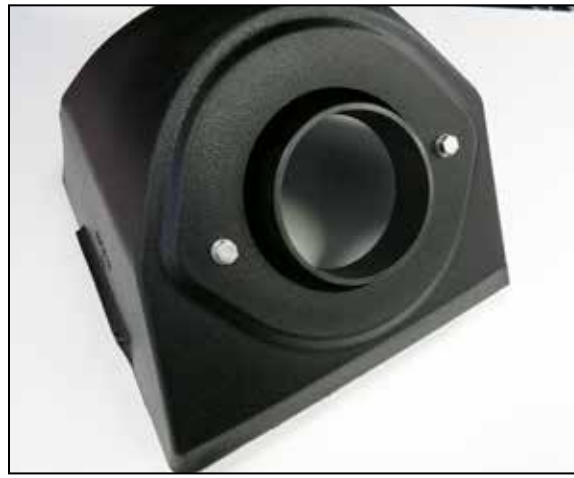

12. Install the filter adapter into the K&N upper air filter housing using the provided hardware.



13. Snap the K&N badge into the K&N upper air filter housing.



14. Install the K&N air filter onto the filter adapter and secure with the provided hose clamp.



15. Install the provided rubber mounted stud into the inner fender air filter housing mounting location.



16. Install the K&N fresh air intake duct onto the K&N lower air filter housing. Install the two provided mounting studs onto the K&N lower air filter housing using the provided hardware and then install the assembly into the vehicle.



17. Secure the housing to the rubber mounted stud with the provided hardware.



18. Secure the fresh air duct to the core support using the factory hardware.



19. Install the K&N upper air filter housing assembly onto the lower housing.



20. Install the provided hump coupler and straight coupler onto the factory turbo inlet tubes with the hose clamps but do not tighten the hose clamps.



21. Install the remaining hump coupler onto the K&N upper air filter housing with the provided hose clamps but do not tighten the clamps.



22. Install the K&N intake tube into the three couplers, align for best fit and then tighten all of the hose clamps.



23. Reconnect the IAT sensor electrical connection.



24. On 3.5L Ecoboost vehicles, disconnect the CCV connection shown on the driver side turbo inlet tube.



25. Install the provided CCV insert into the CCV port on the inlet tube. The angled end of the insert needs to be installed with the shorter side towards the turbo and the longer side towards the inlet.

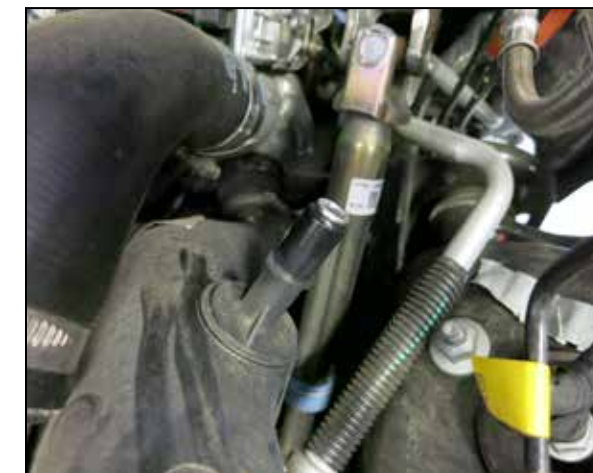

26. Reconnect the CCV connection.



27. Reconnect the vehicle's negative battery cable. Double check to make sure everything is tight and properly positioned before starting the vehicle.

28. It will be necessary for all K&N® high flow intake systems to be checked periodically for realignment, clearance and tightening of all connections. Failure to follow the above instructions or proper maintenance may void warranty.

ROAD TESTING:

1. Start the engine with the transmission in neutral or park, and the parking brake engaged. Listen for air leaks or odd noises. For air leaks secure hoses and connections. For odd noises, find cause and repair before proceeding. This kit will function identically to the factory system except for being louder and much more responsive.

2. Test drive the vehicle. Listen for odd noises or rattles and fix as necessary.

3. If road test is fine, you can now enjoy the added power and performance from your kit.

4. K&N Engineering, Inc., requires cleaning the intake system's air filter element every 100,000 miles. When used in dusty or off-road environments, our filters will require cleaning more often. We recommend that you visually inspect your filter once every 25,000 miles to determine if the screen is still visible. When the screen is no longer visible some place on the filter element, it is time to clean it. To clean and re-oil, purchase our filter Recharger® service kit, part number 99-5050 or 99-5000 and follow the easy instructions.

NOT LEGAL FOR SALE OR USE ON ANY POLLUTION CONTROLLED MOTOR VEHICLE IN CALIFORNIA OR STATES ADOPTING CALIFORNIA EMISSION PROCEDURES.

See knfilters.com for CARB status on each part for a specific vehicle