



AIRCHARGER[®]

HIGH-FLOW INTAKE KITS

NOT LEGAL FOR SALE OR USE ON ANY POLLUTION CONTROLLED MOTOR VEHICLE IN CALIFORNIA OR STATES ADOPTING CALIFORNIA EMISSION PROCEDURES.

INSTALLATION INSTRUCTIONS

63-2609
FORD
2017-19 F150 / Raptor
V6-3.5L Ecoboost

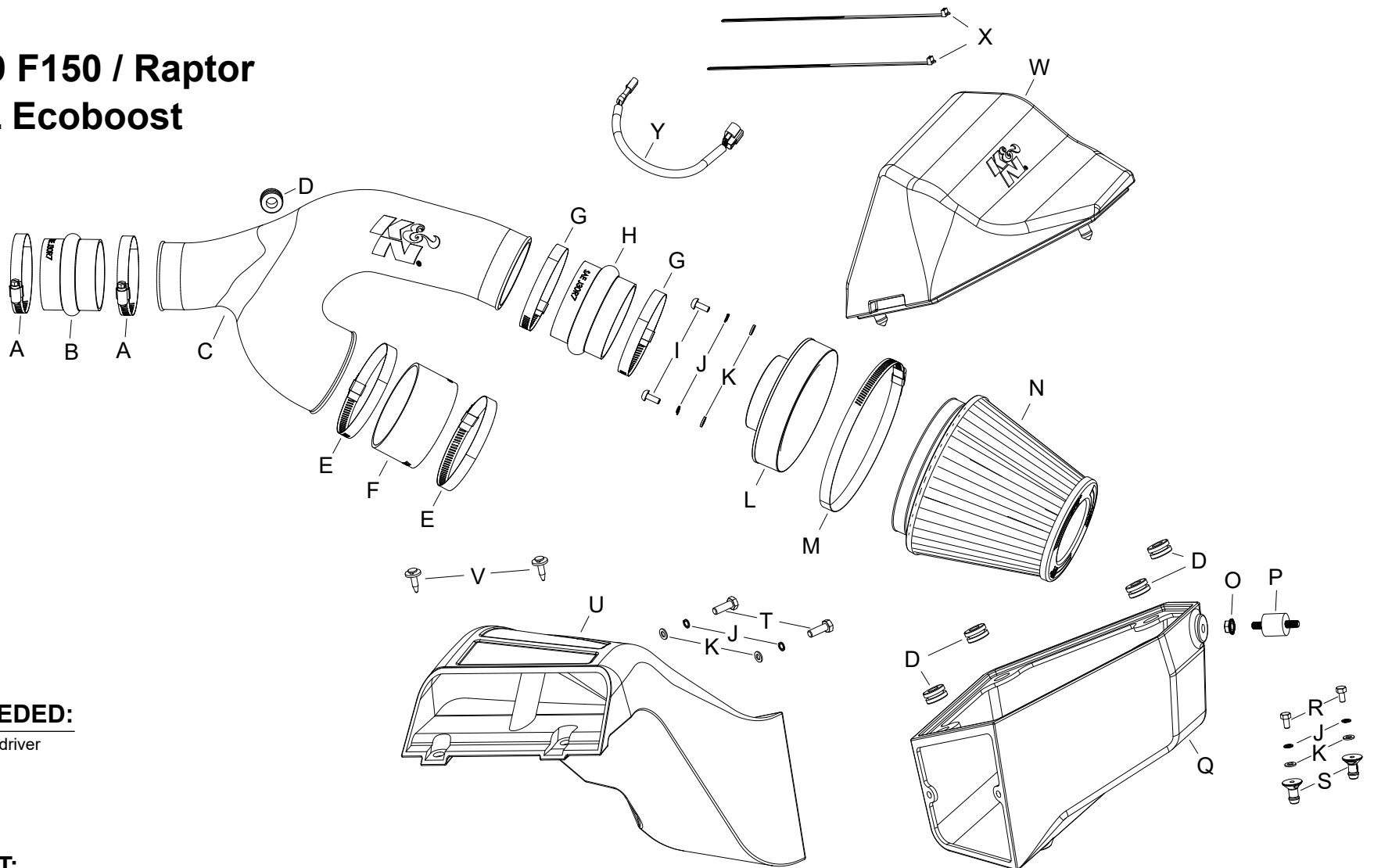

TOOLS NEEDED:

- Flat blade screw driver
- 4mm allen key
- 10mm wrench

PARTS LIST:

Description	Qty.	Part #	Description	Qty.	Part #	Description	Qty.	Part #
A HOSE CLAMP #48	2	08601	I BOLT; M6 X 1.00 X 16MM, SS	2	07730	Q AIRBOX; FIPK, MJ, XLHDPE	1	087426
B HOSE; 3" ID X 2-1/2" L HUMP	1	087121	J WASHER, M6 SPLIT LOCK ZINC	6	1-3025	R BOLT; M6 X 1.00 X 12MM, SS	2	07727
C INTAKE TUBE (MA)	1	087353A	K WASHER; 6MM FLAT, SS	6	08269	S MOUNT, PLASTIC AIRBOX	2	8-186-1
D GROMMET; 1"OD, 1/2"ID, 1/2"	5	08064	L ADAPTER; UNIVERSAL, 6"	1	21512-1	T BOLT; 6MM-1.00 X 16MM, SS	2	07812
E HOSE CLAMP #64 STAINLESS	2	08645	M HOSE CLAMP; #104	1	08697	U SCOOP; FIPK, ML, XLHDPE	1	087428
F HOSE; 4" ID X 2" L	1	08761	N FILTER CHARGER	1	RF-10420	V CLIP; RETAINER BODY NYLON	2	KITRETCLIP02
G HOSE CLAMP #56	2	08620	O NUT; M8, HEX, SERRATED	1	444.460.08	W LID, FIPK 63-2607, MK, XLHDPE	1	087427
H HOSE; 3-1/2" ID X 2-1/2" L	1	08699	P MOUNT, RUBBER 1" X 8MM	1	1228560	X CABLE TIES; 11" BLACK	2	21590
						Y EXTENSION HARNESS	1	21783

NOTE: FAILURE TO FOLLOW INSTALLATION INSTRUCTIONS AND NOT USING THE PROVIDED HARDWARE MAY DAMAGE THE INTAKE TUBE, THROTTLE BODY AND ENGINE.

TO START:

1. Turn off the ignition and disconnect the negative battery cable.
NOTE: Disconnecting the negative battery cable erases pre-programmed electronic memories. Write down all memory settings before disconnecting the negative battery cable. Some radios will require an anti-theft code to be entered after the battery is reconnected. The anti-theft code is typically supplied with your owner's manual. In the event your vehicles anti-theft code cannot be recovered, contact an authorized dealership to obtain your vehicles anti-theft code.



2. Disconnect the inlet air temperature sensor electrical connection.



3. Loosen the hose clamp that secures the factory intake tube to the factory upper air filter housing.



4. Release the two retaining clips that secure the upper air filter housing and then remove the upper housing from the vehicle.
NOTE: K&N Engineering, Inc., recommends that customers do not discard factory air intake.



5. Loosen the two remaining hose clamps that secure the factory intake tube to the turbo inlet pipes and then remove the intake tube from the vehicle.



6. Release the two clips that secure the factory fresh air intake duct to the core support.



7. Disconnect the wiring harness and purge solenoid from the lower air filter housing if equipped. Remove the bolt that secures the lower air filter housing to the inner fender and then remove the lower housing from the vehicle.

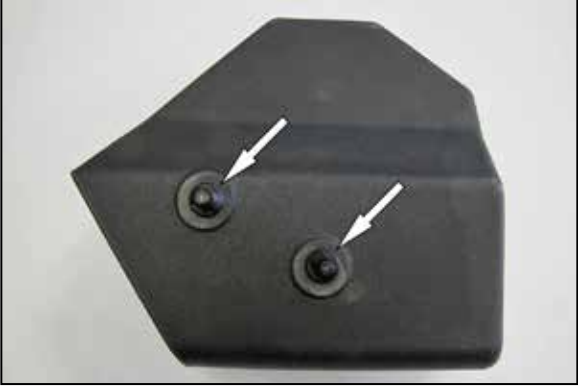

8. Install the two mounting studs provided into the K&N® lower air filter housing as shown using the provided hardware.



9. Install the four mounting grommets provided into the K&N® lower air filter housing as shown.



10. Using the provided hardware, secure the K&N® fresh air duct to the lower housing as shown.



11. Install the rubber mounted stud into the factory inner fender air filter housing mounting location as shown.



12. Install the K&N® lower air filter housing assembly into the vehicle so the mounting studs insert into the factory mounting grommets and it aligns with the rubber mounted stud installed into the inner fender. Secure the assembly with the hardware and clips provided.



13. Install the filter adapter into the filter and secure with the provided hose clamp.



14. Install the air filter assembly into the upper air filter housing and secure with the provided hardware.



15. Install the K&N® lid/filter assembly onto the lower filter housing so the mounting studs engage into the mounting grommets.



16. Install the provided hump coupler (08699) onto the filter adapter and secure with the provided hose clamp.



17. Install the provided hump coupler (087121) onto the upper (passenger side) turbo inlet pipe and coupler (08761) onto the lower (Drivers side) turbo inlet pipe and secure with the provided hose clamps.



18. Remove the inlet air temperature sensor from the factory intake tube and remove the O-ring from the sensor. Using the provided grommet, install the inlet air temperature sensor into the K&N® intake tube as shown.



19. Install the K&N® intake tube into the couplers for the turbo inlet pipes and the filter adapter, adjust the tube for best fit and then secure with the provided hose clamps.



20. Reconnect the inlet air temperature sensor electrical connection using the provided extension harness.

NOTE: Use the provided tie wraps to secure the inlet temperature sensor electrical connection as necessary.



21. Reconnect the vehicle's negative battery cable. Double check to make sure everything is tight and properly positioned before starting the vehicle.

22. It will be necessary for all K&N® high flow intake systems to be checked periodically for realignment, clearance and tightening of all connections. Failure to follow the above instructions or proper maintenance may void warranty.

ROAD TESTING:

1. Start the engine with the transmission in neutral or park, and the parking brake engaged. Listen for air leaks or odd noises. For air leaks secure hoses and connections. For odd noises, find cause and repair before proceeding. This kit will function identically to the factory system except for being louder and much more responsive.

2. Test drive the vehicle. Listen for odd noises or rattles and fix as necessary.

3. If road test is fine, you can now enjoy the added power and performance from your kit.

4. K&N Engineering, Inc., requires cleaning the intake system's air filter element every 100,000 miles. When used in dusty or off-road environments, our filters will require cleaning more often. We recommend that you visually inspect your filter once every 25,000 miles to determine if the screen is still visible. When the screen is no longer visible some place on the filter element, it is time to clean it. To clean and re-oil, purchase our filter Recharger® service kit, part number 99-5050 or 99-5000 and follow the easy instructions.

NOT LEGAL FOR SALE OR USE ON ANY POLLUTION CONTROLLED MOTOR VEHICLE IN CALIFORNIA OR STATES ADOPTING CALIFORNIA EMISSION PROCEDURES.