



# AIRCHARGER®

## HIGH-FLOW INTAKE KITS

NOT LEGAL FOR SALE OR USE ON ANY POLLUTION CONTROLLED MOTOR VEHICLE IN CALIFORNIA OR STATES ADOPTING CALIFORNIA EMISSION PROCEDURES.

### INSTALLATION INSTRUCTIONS

**63-2607**  
**FORD**  
**2018-19 F-150**  
**V6-3.0L Turbo Diesel**

NOTE: This kit was not designed to fit vehicles with a body lift.

**TOOLS NEEDED:**

- Flat Blade Screw Driver
- 3mm allen key
- 4mm allen key

**PARTS LIST:**

Description	Qty.	Part #
A	TUBE; FIPK XLHDPE	1 087429
B	GASKET; 3/16" PORON	1 09069
C	ADAPTOR; NYLON 6/6	1 21515-1
D	WASHER; 6MM FLAT, SS	8 08269
E	BOLT; M6 X 1.00 X 16MM, SS	4 07730
F	BOLT; M4 - 0.7 8MM, A/H CAP	2 07733
G	HOSE CLAMP #60 STAINLESS	1 08628
H	HOSE; HUMP 3.5"ID TO 3.75"	1 08639
I	HOSE CLAMP #56	1 08620
J	WASHER, M6 SPLIT LOCK ZINC	6 1-3025
K	ADAPTER; UNIVERSAL, 6"	1 21512-1
L	HOSE CLAMP; #104	1 08697
M	GROMMET; 1"OD,1/2"ID,1/2"	4 08064
N	NUT; M8, HEX, SERRATED	1 444.460.08
O	MOUNT, RUBBER 1" X 8MM	1 1228560
P	AIRBOX; FIPK, MJ, XLHDPE	1 087426
Q	BOLT; M6 X 1.00 X 12MM, SS	2 07727
R	MOUNT, PLASTIC AIRBOX	2 8-186-1
S	BOLT; 6MM-1.00 X 16MM, SS	2 07812
T	SCOOP; FIPK, ML, XLHDPE	1 087428
U	CLIP; RETAINER BODY NYLON	2 KITRETCLIP02
V	FILTER CHARGER	1 RF-10420XD
W	LID, FIPK MK, XLHDPE	1 087427
X	MAF EXTENSION HARNESS	1 21780
Y	CABLE TIES; 11" BLACK	2 21590

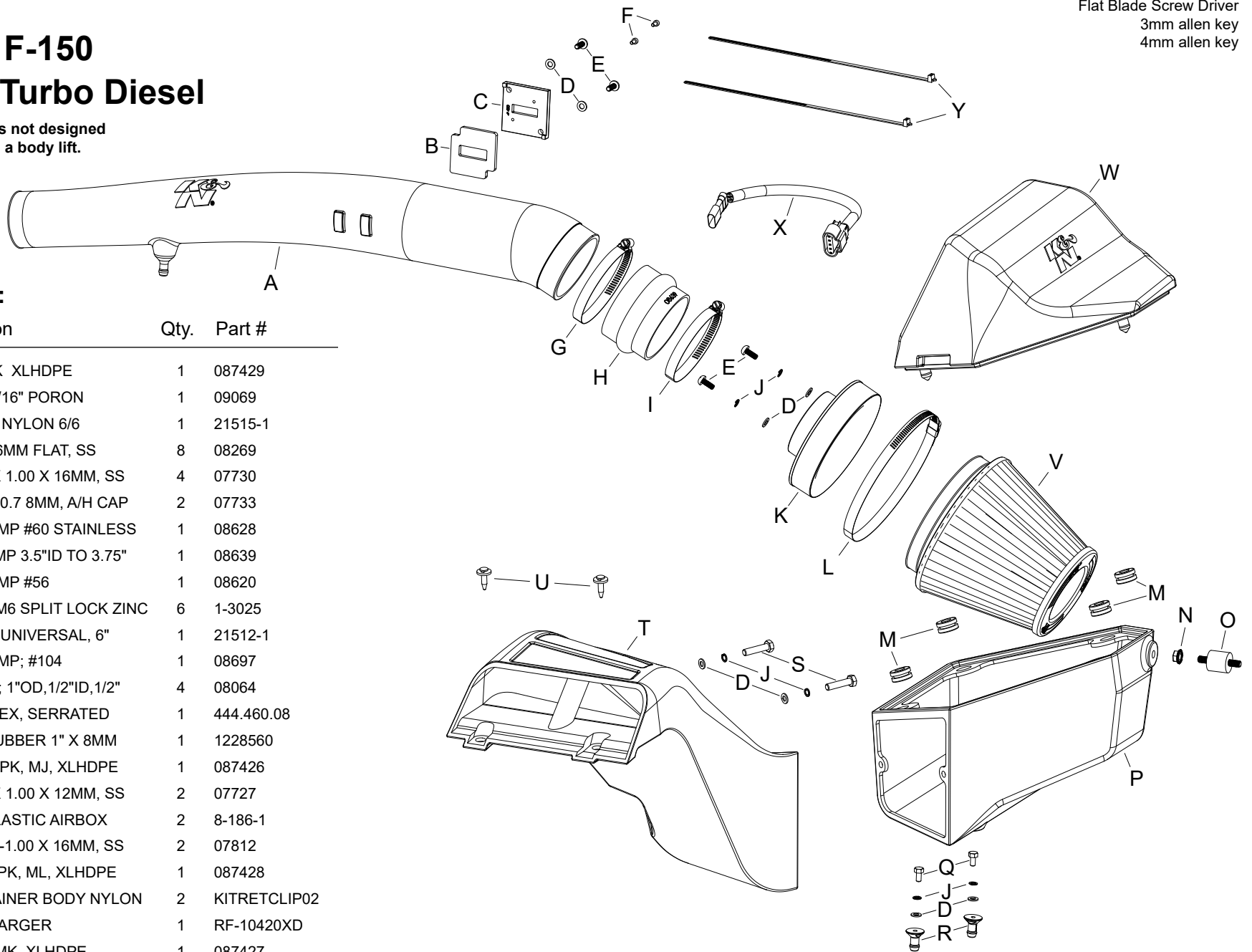

**NOTE: FAILURE TO FOLLOW INSTALLATION INSTRUCTIONS AND NOT USING THE PROVIDED HARDWARE MAY DAMAGE THE INTAKE TUBE, THROTTLE BODY AND ENGINE.**

**TO START:**

1. Turn off the ignition and disconnect the negative battery cable.  
**NOTE: Disconnecting the negative battery cable erases pre-programmed electronic memories. Write down all memory settings before disconnecting the negative battery cable. Some radios will require an anti-theft code to be entered after the battery is reconnected. The anti-theft code is typically supplied with your owner's manual. In the event your vehicles anti-theft code cannot be recovered, contact an authorized dealership to obtain your vehicles anti-theft code.**



2. Disconnect the mass air sensor electrical connection.



3. Disconnect the mass air wiring harness clip from the intake tube.



4. Loosen the two hose clamps that secure the factory intake tube and then remove the tube from the vehicle.



5. Release the two clips that retain the factory upper air filter housing and the remove the upper housing from the vehicle.

**NOTE: K&N Engineering, Inc., recommends that customers do not discard factory air intake.**



6. Remove the two clips that secure the fresh air intake duct to the core support.





7. Disconnect the mass air sensor wiring harness from the lower air filter housing. Remove the bolt that secures the lower air filter housing to the inner fender and then remove the lower housing from the vehicle.

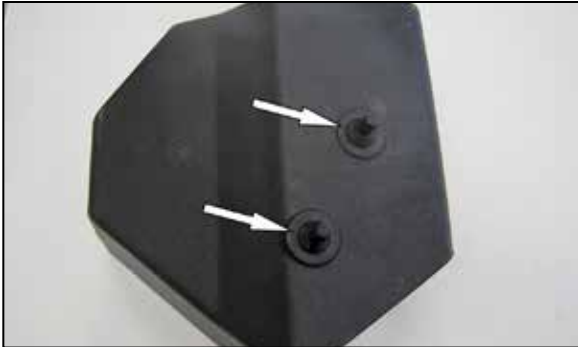

8. Install the two mounting studs provided into the K&N® lower air filter housing.



9. Install the four mounting grommets into the K&N® lower air filter housing.



10. Secure the K&N® fresh air intake duct to the lower air filter housing using the hardware provided.



11. Install the K&N® air filter housing assembly into the vehicle so the mounting studs insert into the factory mounting grommets and then secure with the bolt and retaining clips provided.



12. Install the filter adapter into the K&N® air filter.



13. Install the K&N® air filter assembly into the upper housing using the provided hardware..



14. Install the upper filter housing assembly onto the previously installed lower housing so the mounting studs insert into the grommets.



15. Install the provided hump coupler (08639) onto the filter adapter and secure with the provided hose clamp.



16. Remove the mass air sensor from the factory air filter housing. Assemble the mass air sensor, gasket and adapter as shown using the provided hardware.



17. Install the mass air sensor assembly into the K&N® intake tube as shown using the provided hardware.

**NOTE: The opening of the sensor should be towards the filter end of the tube.**



18. Install the K&N® intake tube assembly into the couplers, adjust for best fit and then secure with the hose clamps.



19. Use the provided extension harness to connect the mass air sensor electrical connection.



20. Secure the mass air sensor wiring harness to the K&N® intake tube.



21. Reconnect the vehicle's negative battery cable. Double check to make sure everything is tight and properly positioned before starting the vehicle.

22. It will be necessary for all K&N® high flow intake systems to be checked periodically for realignment, clearance and tightening of all connections. Failure to follow the above instructions or proper maintenance may void warranty.

#### ROAD TESTING:

1. Start the engine with the transmission in neutral or park, and the parking brake engaged. Listen for air leaks or odd noises. For air leaks secure hoses and connections. For odd noises, find cause and repair before proceeding. This kit will function identically to the factory system except for being louder and much more responsive.

2. Test drive the vehicle. Listen for odd noises or rattles and fix as necessary.

3. If road test is fine, you can now enjoy the added power and performance from your kit.

4. K&N Engineering, Inc., requires cleaning the intake system's air filter element every 100,000 miles. When used in dusty or off-road environments, our filters will require cleaning more often. We recommend that you visually inspect your filter once every 25,000 miles to determine if the screen is still visible. When the screen is no longer visible some place on the filter element, it is time to clean it. To clean and re-oil, purchase our filter Recharger® service kit, part number 99-5050 or 99-5000 and follow the easy instructions.

**NOT LEGAL FOR SALE OR USE ON ANY POLLUTION CONTROLLED MOTOR VEHICLE IN CALIFORNIA OR STATES ADOPTING CALIFORNIA EMISSION PROCEDURES.**