



INTAKE SYSTEMS FOR VEHICLES LISTED ARE 50 STATE LEGAL. SEE KNFILTERS FOR CARB STATUS ON EACH PART FOR A SPECIFIC VEHICLE.

INSTALLATION INSTRUCTIONS

57-3094

CHEVROLET / CADILLAC

2016-20 Camaro

2016-19 CTS

V6-3.6L

TOOLS NEEDED:

- flat blade screw driver
- phillips screw driver
- ratchet
- extension
- 10mm socket
- 10mm wrench
- t20 torx
- t30 torx
- 3mm allen key
- 4mm allen key

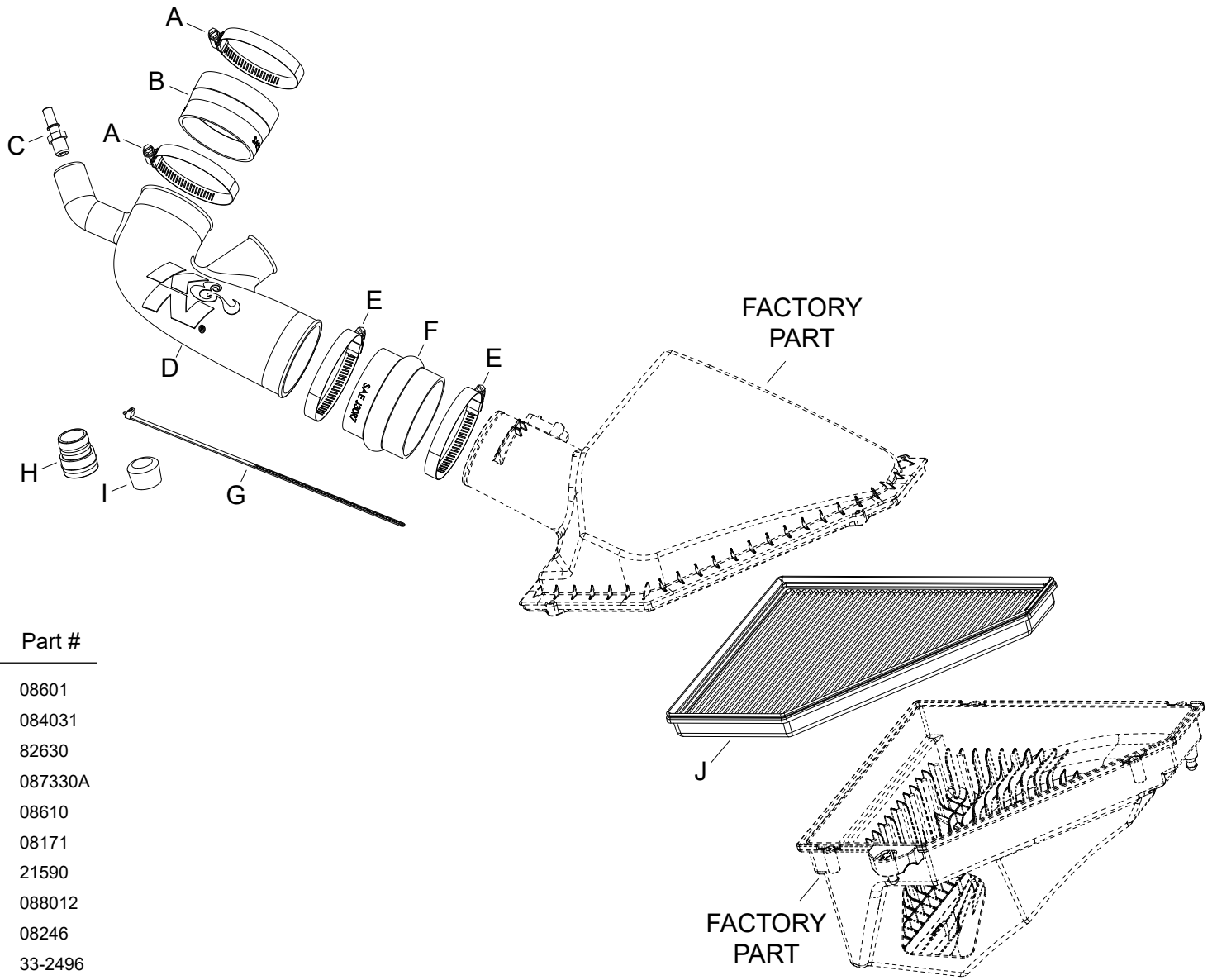

PARTS LIST:

Description	Qty.	Part #
A HOSE CLAMP #48	2	08601
B HOSE; 3-1/8" TO 3" ID X 2" L	1	084031
C VENT; STRT, 1/4NPT TO QUICK	1	82630
D INTAKE TUBE	1	087330A
E HOSE CLAMP #52	2	08610
F HOSE; 3-1/4" ID X 2-5/8" L	1	08171
G CABLE TIES; 11" BLACK	1	21590
H ADAPTOR; 1-1/8"OD QUICK	1	088012
I CAPLUG; 15/16" ID, 3/4" L, BLK	1	08246
J AIR FILTER	1	33-2496

NOTE: FAILURE TO FOLLOW INSTALLATION INSTRUCTIONS AND NOT USING THE PROVIDED HARDWARE MAY DAMAGE THE INTAKE TUBE, THROTTLE BODY AND ENGINE.

TO START:

1. Turn off the ignition and disconnect the negative battery cable.
NOTE: Disconnecting the negative battery cable erases pre-programmed electronic memories. Write down all memory settings before disconnecting the negative battery cable. Some radios will require an anti-theft code to be entered after the battery is reconnected. The anti-theft code is typically supplied with your owner's manual. In the event your vehicles anti-theft code cannot be recovered, contact an authorized dealership to obtain your vehicles anti-theft code.



2. Remove the bolt that secures the decorative engine cover, remove the oil cap and then remove the decorative engine cover. Reinstall the oil cap.



3. Release the locking tap and then disconnect the EVAP vent line quick disconnect fitting from the factory intake tube.



4. On vehicles equipped with an engine sound tube, release the sound tube quick disconnect fitting and disconnect the sound tube from the factory intake tube.



5. Loosen the three hose clamps that secure the intake tube and crank case vent tube and remove the intake tube from the vehicle.
NOTE: K&N Engineering, Inc., recommends that customers do not discard factory air intake.

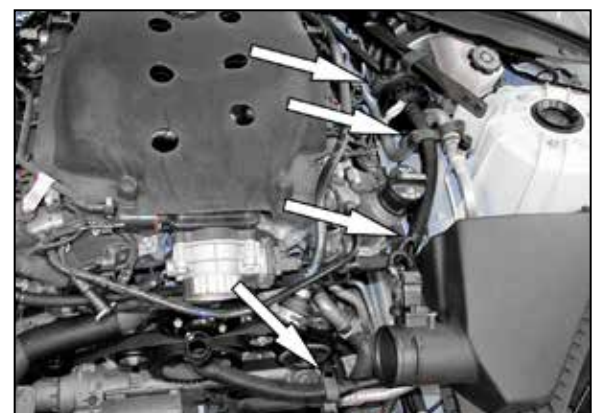

6. On vehicles equipped with an engine sound tube, release the three flexible clamps that secure the sound tube and disconnect the sound drum from the rear sound tube then remove the sound tube assembly. On vehicle that are not equipped with the engine sound tube, skip to step #9.



7. Install the provided caplug onto the quick disconnect union fitting provided.

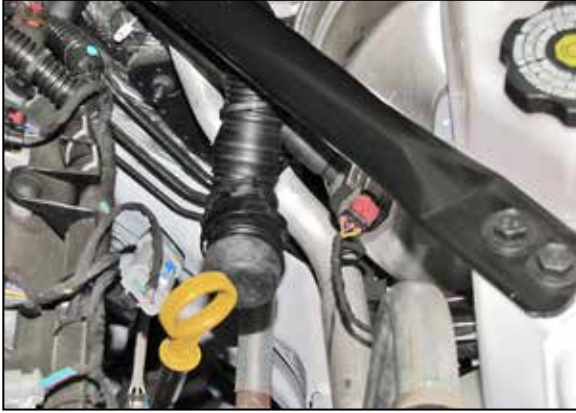

8. Install the caplug assembly into the remaining sound tube and secure with the provided tie wrap.



9. Loosen the screws that secure the upper air filter housing.



10. Remove the upper air filter housing and replace the factory air filter with the provided K&N® air filter. Reinstall the factory air filter housing and secure with the factory screws.



11. Install the provided coupling hose (084031) onto the throttle body and secure with the provided hose clamp.



12. Install the provided hump coupler hose (08171) onto the Mass air sensor outlet and secure with the provided hose clamp.



13. Install the provided quick disconnect NPT fitting into the K&N® intake tube as shown.

NOTE: Plastic NPT fittings are easy to cross thread. Install the vent fitting "hand" tight, then turn it two complete turns with a wrench.



14. Install the K&N® intake tube into the coupling hose at the air box and then into the coupler at the throttle body, adjust the tube for best fit and then secure with the provided hose clamps.



15. Connect the factory EVAP hose quick connector to the quick connector installed into the K&N® intake tube.



16. Connect the crank case fitting onto the K&N® intake tube and secure with the provided hose clamp.



17. Reinstall the decorative engine cover and secure with the factory bolt and oil cap.



18. Reconnect the vehicle's negative battery cable. Double check to make sure everything is tight and properly positioned before starting the vehicle.

19. It will be necessary for all K&N® high flow intake systems to be checked periodically for realignment, clearance and tightening of all connections. Failure to follow the above instructions or proper maintenance may void warranty.

ROAD TESTING:

1. Start the engine with the transmission in neutral or park, and the parking brake engaged. Listen for air leaks or odd noises. For air leaks secure hoses and connections. For odd noises, find cause and repair before proceeding. This kit will function identically to the factory system except for being louder and much more responsive.

2. Test drive the vehicle. Listen for odd noises or rattles and fix as necessary.

3. If road test is fine, you can now enjoy the added power and performance from your kit.

4. K&N Engineering, Inc., requires cleaning the intake system's air filter element every 100,000 miles. When used in dusty or off-road environments, our filters will require cleaning more often. We recommend that you visually inspect your filter once every 25,000 miles to determine if the screen is still visible. When the screen is no longer visible some place on the filter element, it is time to clean it. To clean and re-oil, purchase our filter Recharger® service kit, part number 99-5050 or 99-5000 and follow the easy instructions.

NOT LEGAL FOR SALE OR USE ON ANY POLLUTION CONTROLLED MOTOR VEHICLE IN CALIFORNIA OR STATES ADOPTING CALIFORNIA EMISSION PROCEDURES.