



INSTALLATION INSTRUCTIONS

57-3082

CHEVROLET / GMC / CADILLAC

2014 Silverado 1500 / Sierra 1500

2015 Tahoe / Suburban / Yukon, XL / Escalade, ESV

V8-5.3L / 6.2L

NOTE: This kit was not designed to fit vehicles with a body lift.

TOOLS NEEDED:

- ratchet
- extension
- 10mm socket
- flat blade screw driver
- T10 TORX
- 4mm allen key
- 3mm allen key
- 3/4" wrench.

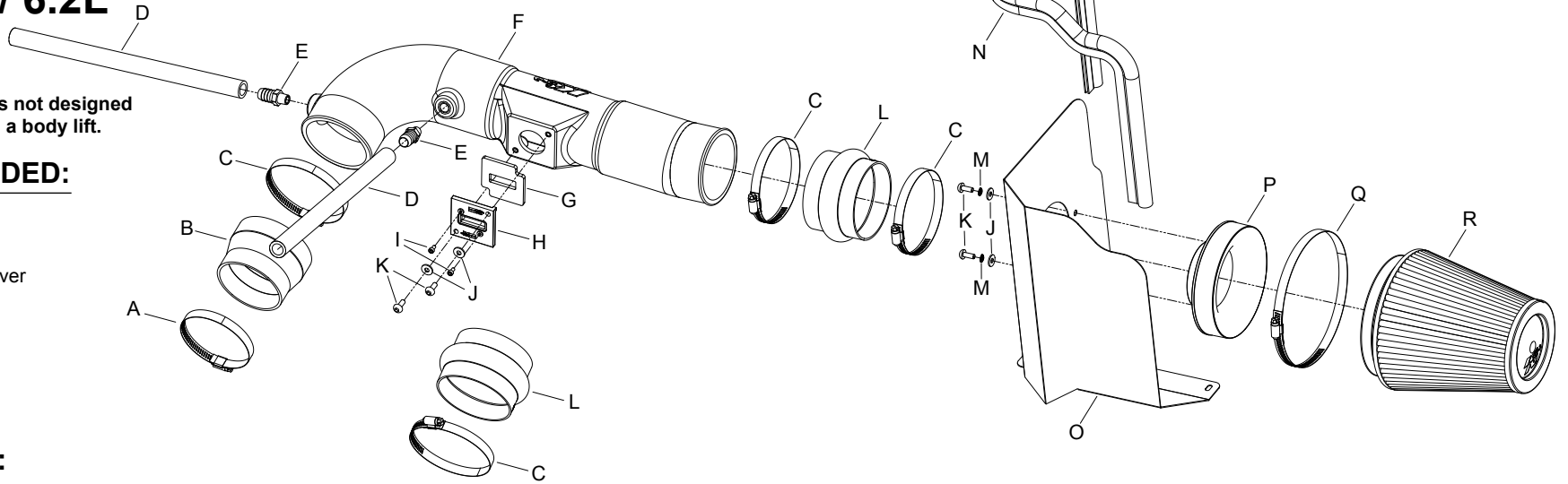

PARTS LIST:

| Description | Qty. | Part # | Description | Qty. | Part # | Description | Qty. | Part # |
|-----------------------------------|------|--------|----------------------------------|------|--------|---------------------------------|------|----------|
| A Hose Clamp #56 | 1 | 08620 | G Gasket; 57-2556, 3/16 poron | 1 | 09069 | M Washer; M6 Split Lock Zinc | 2 | 1-3025 |
| B Hose; 4"ID To 3.5"ID X 3"L TPRD | 1 | 08497 | H Adaptor; 57-2556, Nylon 6/6 GF | 1 | 21515 | N Edge Trim (44") | 1 | 102486 |
| C Hose Clamp #64 Stainless | 4 | 08645 | I Bolt; M4-0.07 8MM, A/H Cap, SS | 2 | 07733 | O Heat Shield | 1 | 073155-1 |
| D Hose; 5/8" ID X 14"L | 2 | 084083 | J Washer; 6MM Flat, SS | 4 | 08269 | P Adapter; Universal, 6" Filter | 1 | 27300 |
| E Vent; STRT, 5/8 Barbed 1/4 NPT | 2 | 08911 | K Bolt; M6 X 1.00 X 16MM, SS | 4 | 07730 | Q Hose Clamp #104 | 1 | 08697 |
| F Intake Tube | 1 | 087268 | L Hose; 4"ID X 3"L Hump | 2 | 08418 | R Air Filter | 1 | RF-1041 |

NOTE: FAILURE TO FOLLOW INSTALLATION INSTRUCTIONS AND NOT USING THE PROVIDED HARDWARE MAY DAMAGE THE INTAKE TUBE, THROTTLE BODY AND ENGINE.

TO START:

1. Turn off the ignition and disconnect the negative battery cable.
NOTE: Disconnecting the negative battery cable erases pre-programmed electronic memories. Write down all memory settings before disconnecting the negative battery cable. Some radios will require an anti-theft code to be entered after the battery is reconnected. The anti-theft code is typically supplied with your owner's manual. In the event your vehicles anti-theft code cannot be recovered, contact an authorized dealership to obtain your vehicles anti-theft code.



2. Disconnect the mass air sensor electrical connection.



3. Disconnect the two crank case vent tubes from the intake plenum.



4. Loosen the two hose clamps securing the intake plenum to the factory air box and to the throttle body.



5. Remove the intake plenum from the vehicle.



6. Pull up the air box to release it from the mounting grommets and then remove the factory air box from the vehicle.

NOTE: It will be necessary to unhook the mass air sensor wiring harness from the air box as it is removed.

NOTE: K&N Engineering, Inc., recommends that customers do not discard factory air intake.

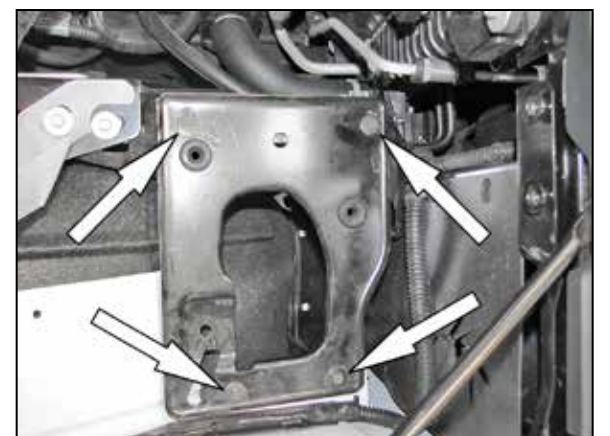

7. Remove the four bolts securing the air box mounting tray and then remove the tray from the vehicle.

NOTE: Three of the bolts will be reused in a latter step.

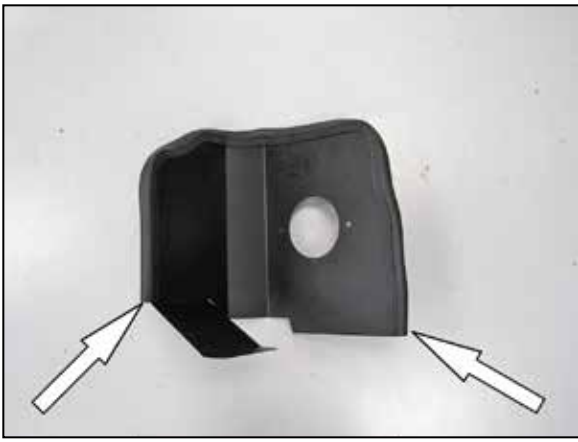

8. Install the provided edge trim onto the heat shield as shown.

NOTE: Some trimming of the edge trim will be necessary.



9. Install the heat shield assembly and secure the air box mounting plate location using the three factory bolts from step #7.



10. Install the filter adapter into the K&N® air filter and secure with the provided hose clamp.



11. Install the filter assembly into the heat shield filter top first, then rotate the filter and pass the adapter through the hole in the heat shield. Secure the filter adapter to the heat shield using the provided hardware.



12. Remove the two factory crank case vent tubes from the vehicle.



13. Install the coupling hose (08497 for 5.3L, 08418 for 6.2L) onto the throttle body and secure with the provided hose clamp.



14. Install the coupling hose (08418) to the filter adapter and secure with the provided hose clamp.



15. Install the provided gasket onto the K&N® mass air sensor adapter as shown.



16. Remove the mass air sensor from the factory air box.



17. Install the mass air sensor into the K&N® adapter and secure with the provided hardware.



18. Install the mass air sensor assembly into the K&N intake tube and secure with the provided hardware.

NOTE: Be sure to install the mass air sensor into the tube in the correct direction, the opening should face the filter end of the intake tube.

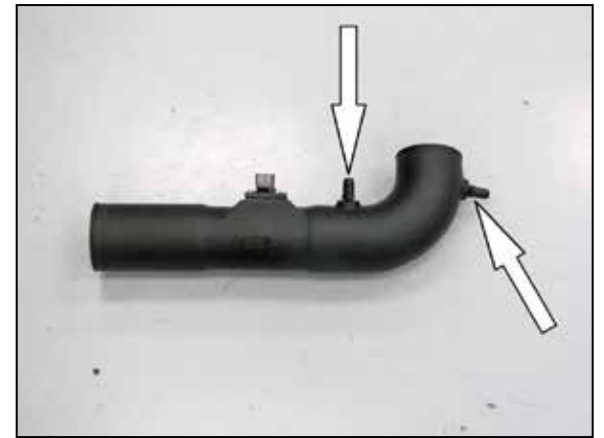

19. Install the two provided crank case vent fittings into the K&N® intake tube as shown.

NOTE: Plastic NPT fittings are easy to cross thread. Install the vent fitting "hand" tight, then turn it two complete turns with a wrench.



20. Install the K&N® intake tube into the hose at the filter adapter and then into the hose at the throttle body, adjust the tube for best fit and then secure with the provided hose clamps.



21. Connect the provided crank case vent hoses to the ports on the valve covers and then connect the open ends to the fittings installed into the K&N® intake tube.



22. Reconnect the mass air sensor electrical connection.



23. Reconnect the vehicle's negative battery cable. Double check to make sure everything is tight and properly positioned before starting the vehicle.

24. The C.A.R.B. exemption sticker, (attached), must be visible under the hood so that an emissions inspector can see it when the vehicle is required to be tested for emissions. California requires testing every two years, other states may vary.

25. **NOTE:** Most General Motors vehicles have the Vehicle Emissions Certification Information (VECI) label affixed to the air filter box. In order to be compliant with California emissions laws, the label **MUST** remain in the engine compartment. If the Vehicle Emission Control Information label is removed during modification, a new replacement label must be obtained and installed in a readily visible position in the engine compartment. The label shall not be affixed to any equipment which is easily detached from the vehicle. We recommend that the label is affixed to the underside of the hood adjacent to the hood latch. The label is Vehicle Identification Number dependent and can be ordered from the vehicle dealership. In order to receive the proper decal please bring your VIN with you. Failure to have the VECI under the hood may result in failure of a pre-registration smog test.

26. It will be necessary for all K&N® high flow intake systems to be checked periodically for realignment, clearance and tightening of all connections. Failure to follow the above instructions or proper maintenance may void warranty.

ROAD TESTING:

1. Start the engine with the transmission in neutral or park, and the parking brake engaged. Listen for air leaks or odd noises. For air leaks secure hoses and connections. For odd noises, find cause and repair before proceeding. This kit will function identically to the factory system except for being louder and much more responsive.

2. Test drive the vehicle. Listen for odd noises or rattles and fix as necessary.

3. If road test is fine, you can now enjoy the added power and performance from your kit.

4. K&N Engineering, Inc., requires cleaning the intake system's air filter element every 100,000 miles. When used in dusty or off-road environments, our filters will require cleaning more often. We recommend that you visually inspect your filter once every 25,000 miles to determine if the screen is still visible. When the screen is no longer visible some place on the filter element, it is time to clean it. To clean and re-oil, purchase our filter Recharger® service kit, part number 99-5050 or 99-5000 and follow the easy instructions.