

PLEASE READ THE INSTRUCTIONS CAREFULLY BEFORE FITTING THE KIT.

- 1 Loosen the two retaining bolts holding the air box, unhook the rubber retaining strap, raise the air box and disconnect the breather pipe from the underside.
- 2 Remove the complete air filter system including the two air hoses.
- 3 Remove the rubber sealing ring from the underside of the air box and fit the **deepest** groove side of the seal to the end of the metal tube which is furthest from the mounting brackets. **Drawing A.**
- 4 Locate the tube on to the throttle body and bolt **firmly** into position using the two dome head screws supplied. **It is vital that these are sealed in position using a quality thread-locking compound.**
- 5 Fit the breather hose to the tube. **Drawing B.**
- 6 Clamp the filter unit to the intake manifold tube adjusting until the K&N logo is straight before tightening **firmly** in place. **Don't overtighten the clips.**
- 7 **Cold Air Supply Hose.**
Unclip the radiator top shield from the side pieces and fold back to reveal the front of the radiator.
- 8 Fold back the vertical flap on the left hand side of the radiator until it is clear of the front panel and there is sufficient gap for the cold air hose to be located. **Drawing B.**
- 9 Carefully expand the air hose to 30" (760mm). Feed the air supply hose through the gap between the radiator and vehicle front panel just opened.
- 10 Position the air hose just behind the grille. Pierce a suitable hole in the end of the air hose and tie-wrap the hose to the grille. **Drawing C.**
- 11 Feed the other end of the cold air hose up to the new filter and secure the end of the hose to finish approximately 10cm / 4" from the filter (**no nearer**) with the second tie-wrap. **Drawing B.**
- 12 Replace the radiator top shield in its original position.
- 13 **Tuning.**
CAT. Cars. No adjustments are required.
An increase in fuel mixture may be required if further modifications are carried out.
- 14 **Filter maintenance.**
Under normal conditions clean and reoil the filter at approx. 40,000 miles / 65,000 Km.
Use only K&N cleaner and oil and follow the instructions carefully.

K&N filters are pre-oiled ready to fit.

The advantage's of K&N's cold air intake system.

Cooler air being denser, will show positive improvements in power over filter systems that draw hot air from the engine bay.

This Kit Should Contain :-

- 1 x Air filter.
- 1 x Mounting tube.
- 1 x Cold air hose assembly.
- 1 x Instruction sheet.
- 1 x Instruction pack:-
 - 1 x Filter maintenance sheet.
 - 1 x K&N window sticker.
 - 1 x Million mile warranty card.
 - 1 x Leaflet.
- 1 x Fixing kit containing :-
 - 2 x Plastic cable ties (35cm long).
 - 2 x M6 Allen screws.
 - 1 x Hose Clip #72

**IMPORTANT INSTRUCTIONS
FOR ROUND ENTRY
CLAMP ON AIR FILTERS**

Gently tighten the hose clip to the point where the filter will just rotate on the pipe or intake flange. Reposition the K&N logo straight, then **give the clip two turns i.e. 360 , no more.**

FITTING YOUR OWN 57i KIT

If not, **it is essential** that the person fitting the kit (e.g. mechanic) **carefully follows these particular instructions** even if he has fitted K&N kits before. This will save you both time and money. Kits incorrectly fitted may show a loss in performance e.g. the positioning of the essential cold air hose, (flexi expandable and rubber hoses are used).

A final check under the bonnet, by yourself, with the instructions, would seem sensible.

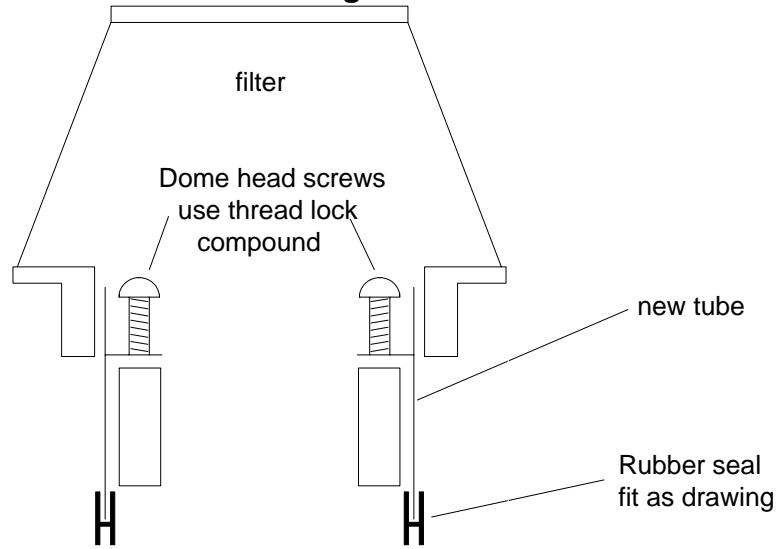

Drawing B

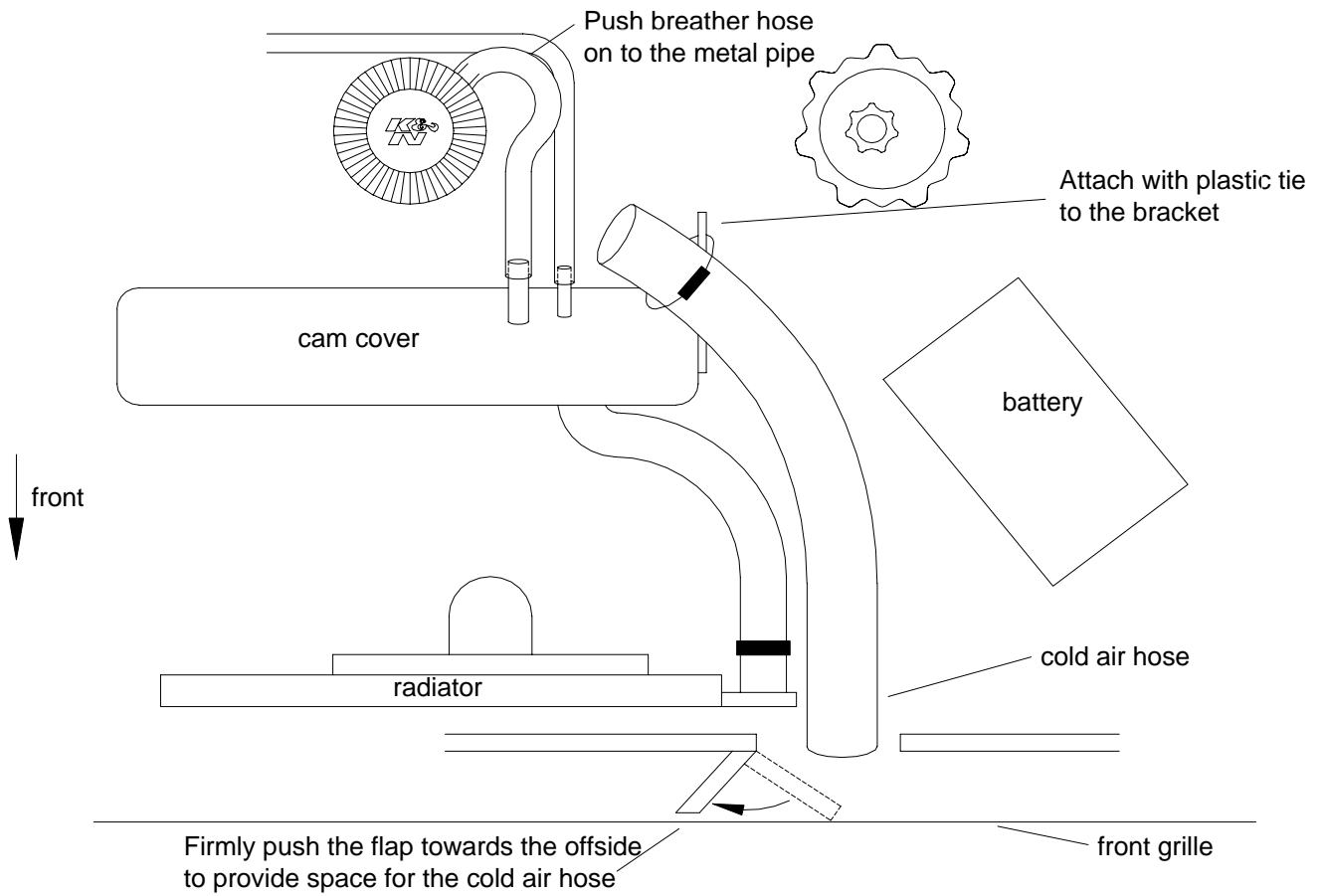

Drawing C

