

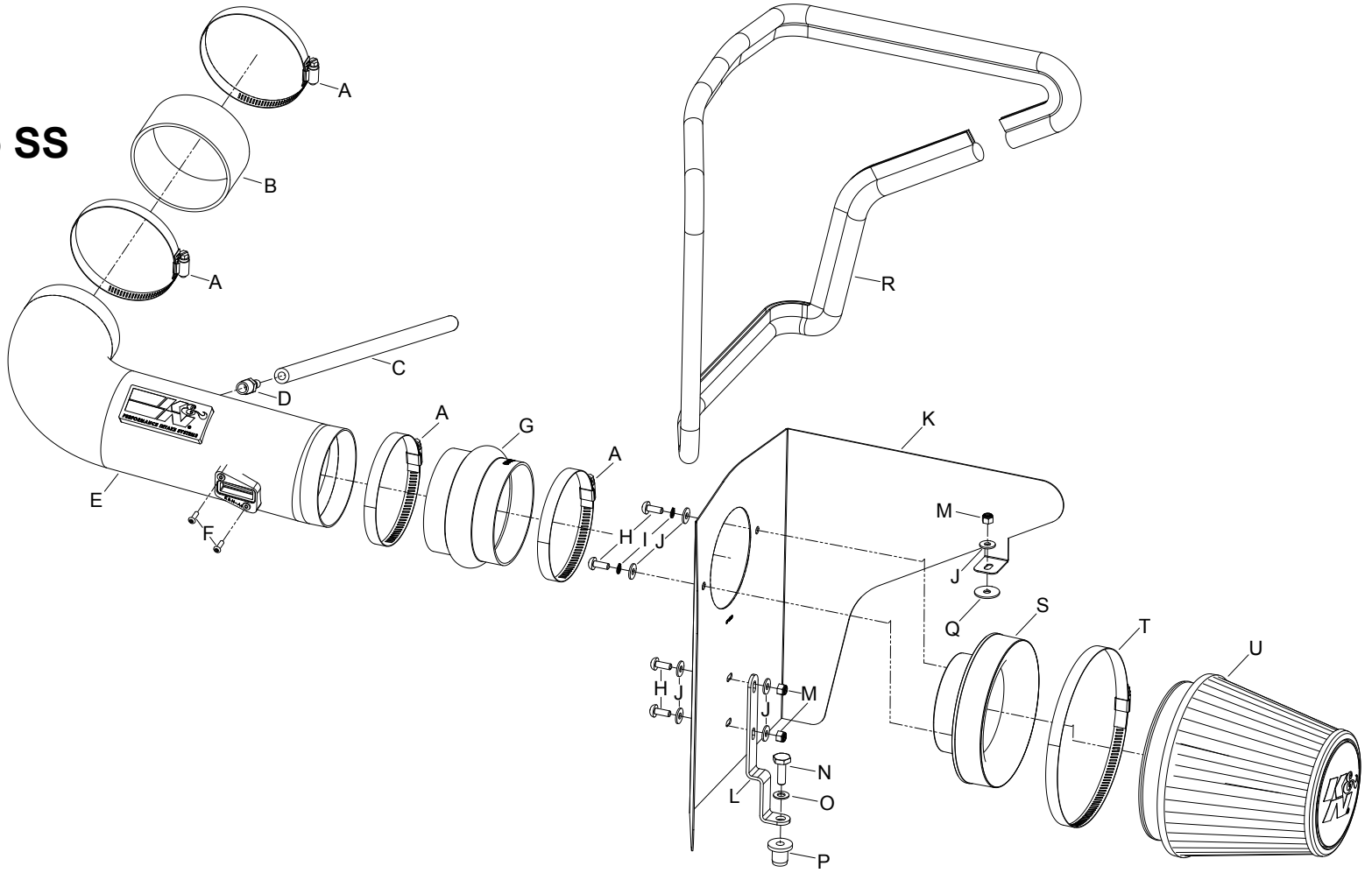

INSTALLATION INSTRUCTIONS

71-4519 CHEVROLET 2010-13 Camaro SS V8-6.2L



TOOLS NEEDED:

- Flat Blade Screw Driver
- Phillips Screw Driver
- Ratchet
- Extension
- 13mm Wrench
- 10mm Socket
- 4mm Allen Wrench
- 3mm Allen Wrench

PARTS LIST:

Description	Qty.	Part #	Description	Qty.	Part #	Description	Qty.	Part #
A Hose Clamp #64, Black Zinc	4	08645K	H Bolt; M6 X 1.00 X 16MM, SS	4	07730	O Washer; 5/16"ID X 5/8"OD, Flat	1	08276
B Hose; 4"ID X 2"L Reinforced	1	08761	I Washer; M6 Split Lock Zinc	2	1-3025	P Insert; 5/16-18 X .600 OD Rubber	1	088002
C Hose; 8MM ID X 21"L	1	08409	J Washer; 6MM Flat, SS	7	08269	Q Washer; 1" X .300 X .100 Rubber	1	21685
D Vent; STRT, 5/16" Barbed	1	08908	K Heat Shield	1	074053	R Edge Trim (70")	1	102454
E Intake Tube	1	27584TK	L Bracket; "Z", 63-3074, STL	1	083126	S Adaptor; 57-3058 #454	1	27300
F Bolt; M4 X .7 X 8MM, Buttonhead	2	07741	M Nut; 6MM Nylock, Hexhead, SS	3	07512	T Hose Clamp #104, Black Zinc	1	08697K
G Hose; 4"ID X 3"L Hump	1	08418	N Bolt; 5/16" -18 X 1"L,SS	1	07777	U Air Filter	1	RU-3102-HBK

NOTE: FAILURE TO FOLLOW INSTALLATION INSTRUCTIONS AND NOT USING THE PROVIDED HARDWARE MAY DAMAGE THE INTAKE TUBE, THROTTLE BODY AND ENGINE.

TO START:

1. Turn off the ignition and disconnect the negative battery cable.
NOTE: Disconnecting the negative battery cable erases pre-programmed electronic memories. Write down all memory settings before disconnecting the negative battery cable. Some radios will require an anti-theft code to be entered after the battery is reconnected. The anti-theft code is typically supplied with your owner's manual. In the event your vehicles' anti-theft code cannot be recovered, contact an authorized dealership to obtain your vehicles anti-theft code.



2. Disconnect the mass air sensor electrical connection.



3. Remove the oil filler cap and then lift up and remove the engine cover. Reinstall the oil filler cap.



4. Disconnect the crank case vent tube from the intake resonator as shown.



5. Loosen the hose clamps which secure the stock intake tube to the air box and throttle body.



6. Remove the stock intake tube as shown.



7. Rotate the crank case vent tube 180°, then release the retainer at the valve cover port and the remove the crank case vent tube.



8. Remove the two air box retaining nuts shown.



9. Lift up and remove the air box from the vehicle.
NOTE: K&N Engineering, Inc., recommends that customers do not discard factory air intake.



10. Remove the air box mounting grommet shown from the frame rail.



11. Install the heat shield mounting bracket (083126) onto the heat shield as shown using the provided hardware.

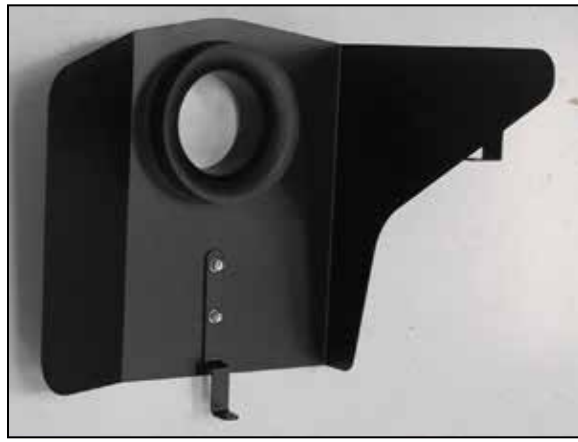

12. Install the filter adapter onto the heat shield and secure with the provided hardware.

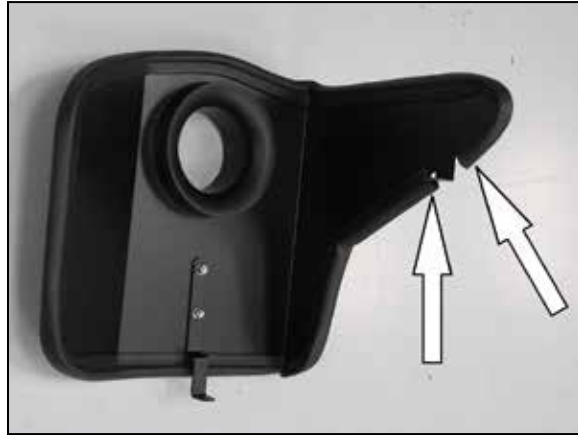

13. Install the edge trim onto the heat shield as shown.
NOTE: Some trimming of the edge trim will be necessary.



14. Install the inserted nut onto the heat shield mounting bracket using the provided hardware. Do not completely tighten at this time.



15. Install the heat shield assembly into the vehicle so the inserted nut goes into the air box mounting grommet hole and the tab goes onto the air box mounting stud. Secure the heat shield with the provided hardware.



16. Install the silicone hose (08761) onto the throttle body and secure with the provided hose clamp.



17. Install the silicone hose (08418) onto the filter adapter and secure with the provided hose clamp.



18. Remove the two screws and then remove the mass air sensor from the factory air box.



19. Install the mass air sensor into the K&N® intake tube and secure with the provided hardware.



20. Install the provided 1/4npt fitting into the K&N® intake tube as shown.
NOTE: Plastic NPT fittings are easy to cross thread. Install the vent fitting "hand" tight, then turn it two complete turns with a wrench.



21. Install the K&N® intake tube assembly into the silicone hose at the filter adapter and then into the silicone hose at the throttle body and secure with the provided hose clamps.



22. Attach the provided crank case vent hose to the 1/4npt fitting and then attach the open end to the vent port on the valve cover.



23. Install the K&N® air filter onto the filter adapter and secure with the provided hose clamp.



24. Reconnect the mass air sensor electrical connection.



25. Reinstall the engine cover.

26. Reconnect the vehicle's negative battery cable. Double check to make sure everything is tight and properly positioned before starting the vehicle.

27. It will be necessary for all K&N® high flow intake systems to be checked periodically for realignment, clearance and tightening of all connections. Failure to follow the above instructions or proper maintenance may void warranty.

ROAD TESTING:

1. Start the engine with the transmission in neutral or park, and the parking brake engaged. Listen for air leaks or odd noises. For air leaks secure hoses and connections. For odd noises, find cause and repair before proceeding. This kit will function identically to the factory system except for being louder and much more responsive.

2. Test drive the vehicle. Listen for odd noises or rattles and fix as necessary.

3. If road test is fine, you can now enjoy the added power and performance from your kit.

4. K&N Engineering, Inc., requires cleaning the Blackhawk Induction™ intake system's air filter element every 100,000 miles. When used in dusty or off-road environments, our filters will require cleaning more often. We recommend that you visually inspect your filter once every 25,000 miles to determine if the screen is still visible. When the screen is no longer visible some place on the filter element, it is time to clean it. To clean, purchase our Synthetic Filter Cleaner, part number 99-0624 and follow the easy instructions.