



## INSTALLATION INSTRUCTIONS

71-3527

FORD

2011-14 Mustang GT

V8-5.0L

### TOOLS NEEDED:

- Flat Blade Screw Driver
- Ratchet
- Extension 3mm
- 13mm Socket
- 10mm Socket
- 8mm Socket
- Allen Key
- Pliers
- T20 torx

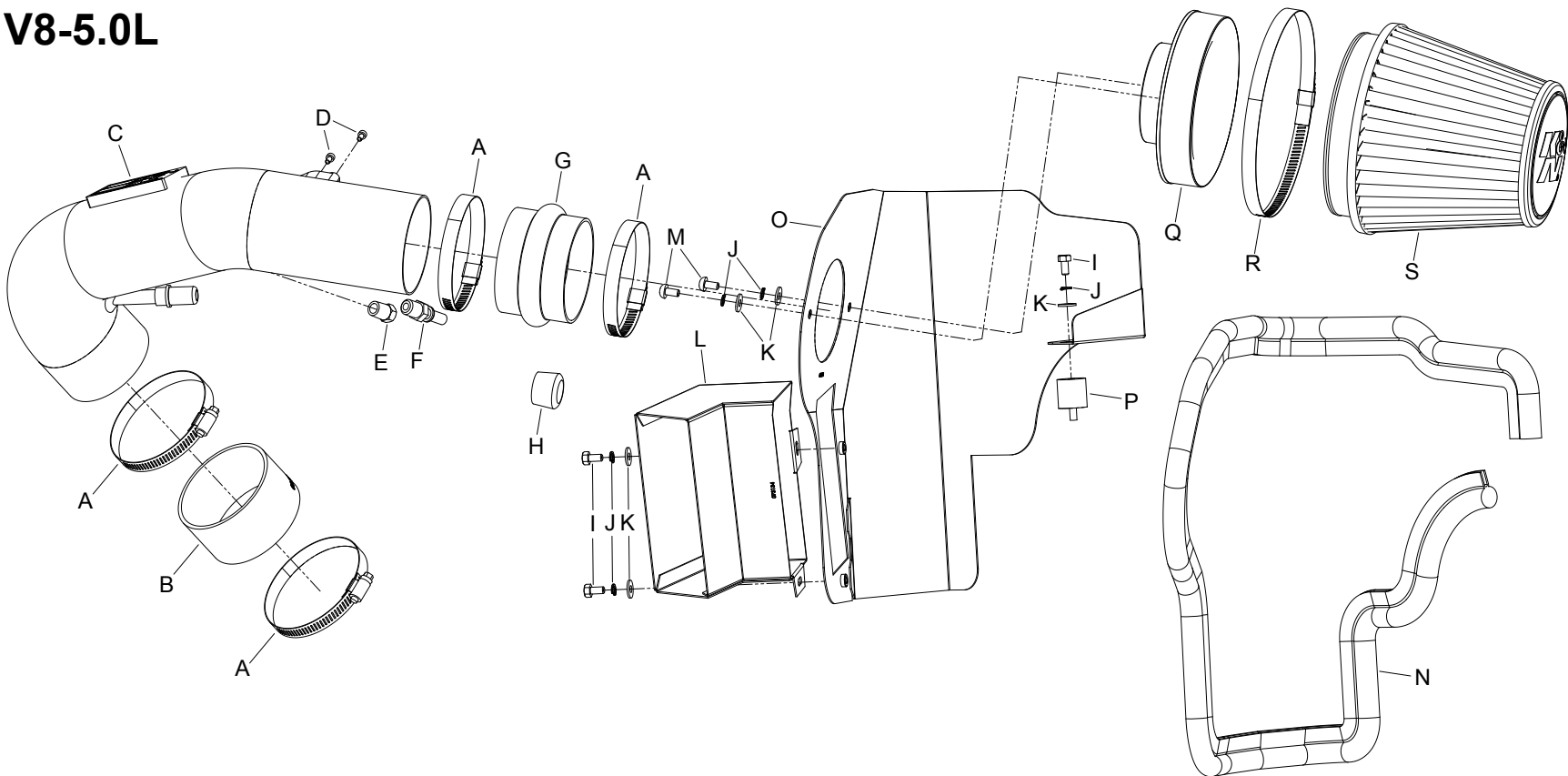

### PARTS LIST:

| Description                        | Qty. | Part #  | Description                     | Qty. | Part # | Description                          | Qty. | Part #     |
|------------------------------------|------|---------|---------------------------------|------|--------|--------------------------------------|------|------------|
| A Hose Clamp #56, Black Zinc       | 4    | 08620K  | H Caplug; 15/16" ID, 3/4"L, BLK | 1    | 08246  | N Edge Trim (57")                    | 1    | 102470     |
| B Hose; 3-1/2" ID X 2"L Reinforced | 1    | 08698   | I Bolt; M6 X 1.00 X 12MM, SS    | 3    | 07727  | O Heat Shield                        | 1    | 073135     |
| C Intake Tube                      | 1    | 27331TK | J Washer; M6 Split Lock Zinc    | 5    | 1-3025 | P Stud; Rubber Mount, M6 X 1, 1"T    | 1    | 02033      |
| D Bolt; M4-0.07 8MM, A/H Cap, SS   | 2    | 07733   | K Washer; 6MM Flat, SS          | 5    | 08269  | Q Adapter; Universal, 6" Filter 3.5" | 1    | 21512-1    |
| E Plug; 1/4 NPT, Plastic, Black    | 1    | 08032   | L Air Scoop                     | 1    | 073134 | R Hose Clamp #104, Black Zinc        | 1    | 08697K     |
| F Vent; STRT; 1/4"NPT To Quick     | 1    | 08938   | M Bolt; M6 X 1.00" 12MM SS      | 2    | 07794  | S <a href="#">Air Filter</a>         | 1    | RU-3102HBK |
| G Hose; 3-1/2"ID X 2-1/2"L Hump    | 1    | 08699   |                                 |      |        |                                      |      |            |

**NOTE: FAILURE TO FOLLOW INSTALLATION INSTRUCTIONS AND NOT USING THE PROVIDED HARDWARE MAY DAMAGE THE INTAKE TUBE, THROTTLE BODY AND ENGINE.**

### TO START:

1. Turn off the ignition and disconnect the negative battery cable.

**NOTE: Disconnecting the negative battery cable erases pre-programmed electronic memories. Write down all memory settings before disconnecting the negative battery cable. Some radios will require an anti-theft code to be entered after the battery is reconnected. The anti-theft code is typically supplied with your owner's manual. In the event your vehicles' anti-theft code cannot be recovered, contact an authorized dealership to obtain your vehicles anti-theft code.**



2. On vehicles equipped with a strut tower brace, remove the four nuts that secure the brace and then remove the brace from the vehicle.



3. Lift up the engine cover to dislodge it from the mounts and then remove it from the vehicle.



4. Cut the clamp that secures the engine pulse hose to the drum and disconnect the hose from the drum.



5. Release the clamp that secures the pulse hose to the intake tube and then remove the pulse hose from the vehicle.



6. Install the provided cap onto the drum as shown.





7. Disconnect the mass air sensor electrical connection.



8. Disconnect the crank case vent hose from the intake tube.

**NOTE: Some models may be equipped with a EVAP vent line, it will be necessary to disconnect the EVAP vent hose from the factory intake tube.**



9. Loosen the hose clamp that secures the factory intake tube to the throttle body.

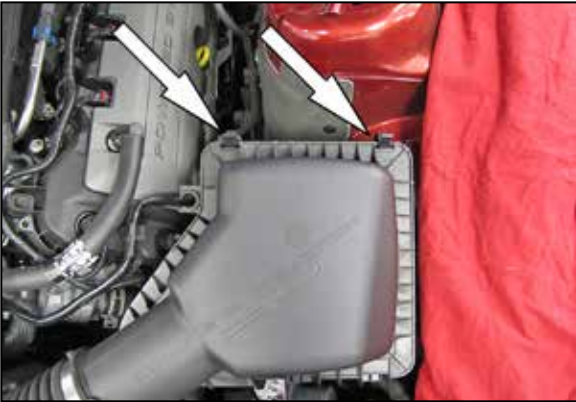

10. Release the two upper air box retaining clips and then remove the upper air box and intake tube from the vehicle.



11. Remove the bolt that secures the lower air box to the inner fender and then remove the lower air box from the vehicle.

**NOTE: K&N Engineering, Inc., recommends that customers do not discard factory air intake.**

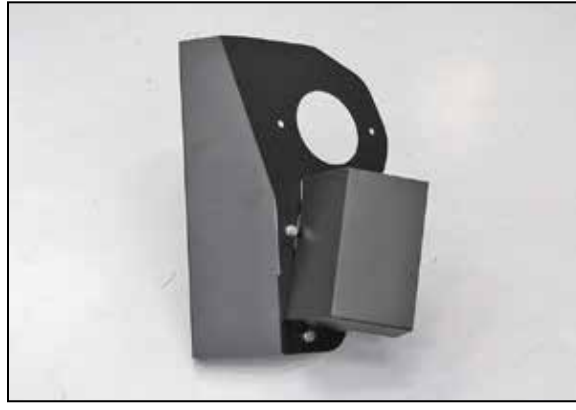

12. Secure the fresh air intake scoop to the heat shield using the provided hardware.



13. Install the filter adapter into the heat shield and secure with the provided hardware.



14. Install the provided edge trim around the heat shield as shown.

**NOTE: Some trimming of the edge trim will be necessary.**



15. Install the provided rubber mounted stud onto the inner fender in the air box mounting location as shown.

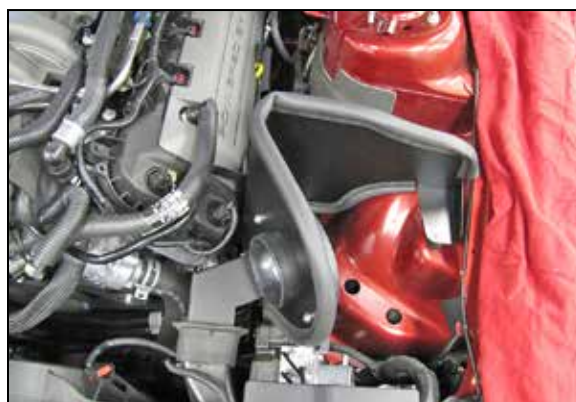

16. Install the heat shield so that the fresh air scoop enters into the factory duct and align the mounting hole with the rubber mounted stud, then secure with the provided hardware.



17. Install the provided silicone hump hose (08699) onto the filter adapter and secure with the provided hose clamp.



18. Install the provided silicone hose (08698) onto the throttle body and secure with the provided hose clamp.



19. On vehicles equipped with an EVAP vent line, install the provided quick disconnect fitting into the K&N® intake tube. On vehicles not equipped with the EVAP vent line, install the provided 1/4npt plug into the K&N® intake tube.

**NOTE: Plastic NPT fittings are easy to cross thread. Install the vent fitting "hand" tight, then turn it two complete turns with a wrench.**



20. Remove the two screws securing the mass air sensor into the upper air box and then remove the mass air sensor from the air box.



21. Install the mass air sensor into the K&N® intake tube and secure with the provided hardware.





22. Install the K&N® intake tube into the silicone hoses, align for best fit and then secure with the provided hose clamps.



23. Connect the crank case vent line and EVAP vent line if equipped as shown.



24. Connect the mass air sensor electrical connection.



25. Reinstall the engine cover.



26. Reinstall the strut tower brace and secure with the factory nuts.



27. Install the K&N® air filter and secure with the provided hose clamp.



28. Reconnect the vehicle's negative battery cable. Double check to make sure everything is tight and properly positioned before starting the vehicle.

29. It will be necessary for all K&N® high flow intake systems to be checked periodically for realignment, clearance and tightening of all connections. Failure to follow the above instructions or proper maintenance may void warranty.

#### ROAD TESTING:

1. Start the engine with the transmission in neutral or park, and the parking brake engaged. Listen for air leaks or odd noises. For air leaks secure hoses and connections. For odd noises, find cause and repair before proceeding. This kit will function identically to the factory system except for being louder and much more responsive.

2. Test drive the vehicle. Listen for odd noises or rattles and fix as necessary.

3. If road test is fine, you can now enjoy the added power and performance from your kit.

4. K&N Engineering, Inc., requires cleaning the Blackhawk Induction™ intake system's air filter element every 100,000 miles. When used in dusty or off-road environments, our filters will require cleaning more often. We recommend that you visually inspect your filter once every 25,000 miles to determine if the screen is still visible. When the screen is no longer visible some place on the filter element, it is time to clean it. To clean, purchase our Synthetic Filter Cleaner, part number 99-0624 and follow the easy instructions.