



TYPHOON INTAKE SYSTEMS

INSTALLATION INSTRUCTIONS

69-9509TTK
VOLKSWAGEN
2013-14 Jetta TDI
L4-2.0L Turbo

TOOLS NEEDED:

- Flat blade screw driver
- Ratchet
- Extension
- 10mm socket
- 5mm allen key
- 4mm allen key
- 10mm wrench
- Pliers.

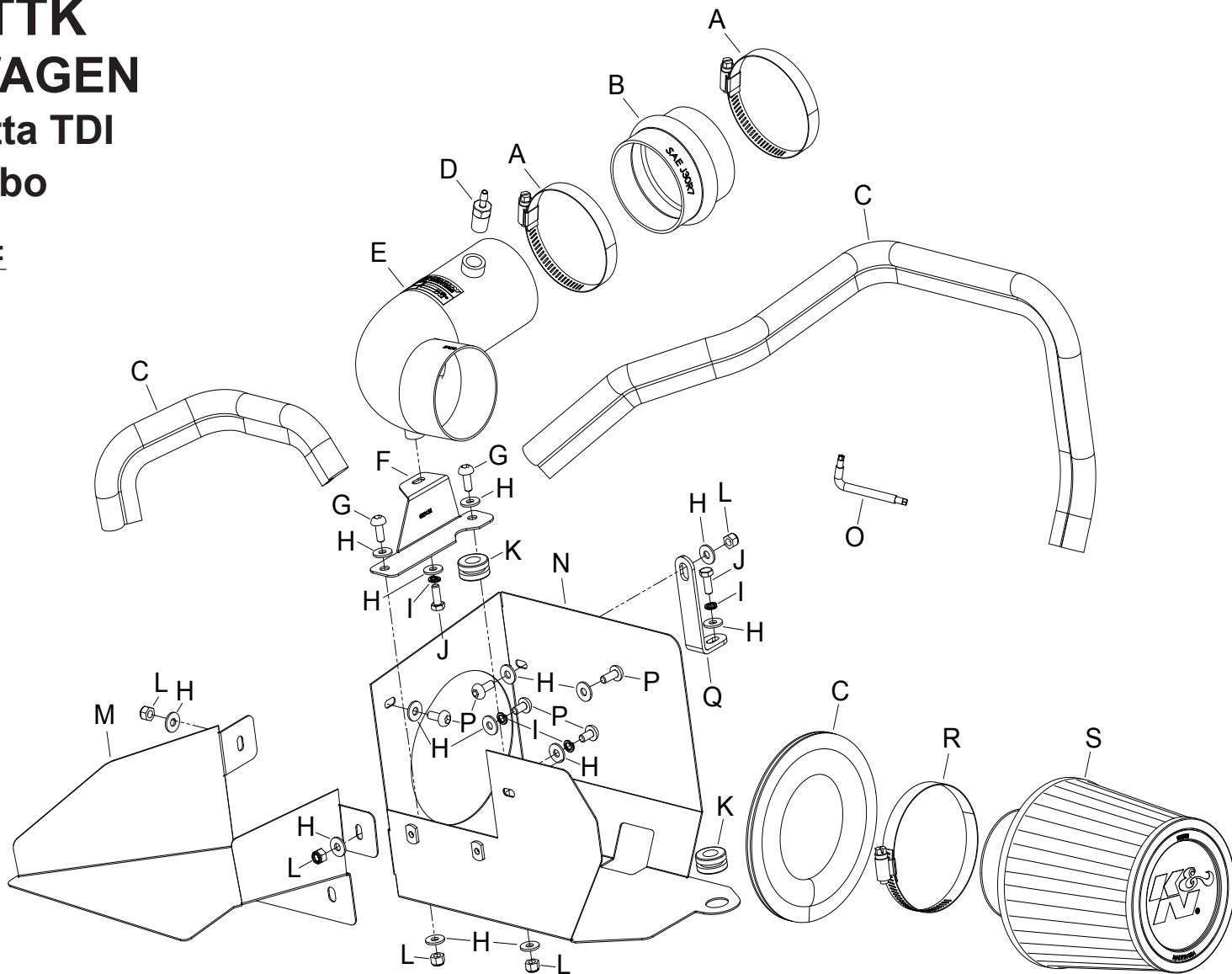

PARTS LIST:

Description	Qty.	Part #	Description	Qty.	Part #	Description	Qty.	Part #
A hose clamp #48	2	08601	H washer; 6mm flat, ss	14	08269	O wrench; torx t20 t/r, l-key	1	69801
B hose; 3" id x 2-1/2" l hump	1	087121	I washer, m6 split lock zinc	4	1-3025	P bolt; m6 x 1.00 x 16mm, ss	5	07730
C edge trim (61")	1	102492	J bolt; 6mm-1.00 x 16mm, ss	2	07812	Q bracket; "l" 69-3510, stl, tb/pc	1	010051
D vent; str, 3/16 barbed 1/4"npt	1	080021	K grommet; 1"od,1/2"id,1/2"thk	2	08064	R hose clamp #52	1	08610
E intake tube	1	27630	L nut; 6mm nylock, hexhead, ss	5	07512	S air filter	1	RU-4990
F bracket; "z", 69-9504, mild stl	1	083132	M heat shield scoop	1	074062			
G bolt; m6 x 1.00" 12mm, ss	2	07794	N heat shield	1	074060			

NOTE: FAILURE TO FOLLOW INSTALLATION INSTRUCTIONS AND NOT USING THE PROVIDED HARDWARE MAY DAMAGE THE INTAKE TUBE, THROTTLE BODY AND ENGINE.

TO START:

1. Turn off the ignition and disconnect the negative battery cable.
NOTE: Disconnecting the negative battery cable erases pre-programmed electronic memories. Write down all memory settings before disconnecting the negative battery cable. Some radios will require an anti-theft code to be entered after the battery is reconnected. The anti-theft code is typically supplied with your owner's manual. In the event your vehicles anti-theft code cannot be recovered, contact an authorized dealership to obtain your vehicles anti-theft code.

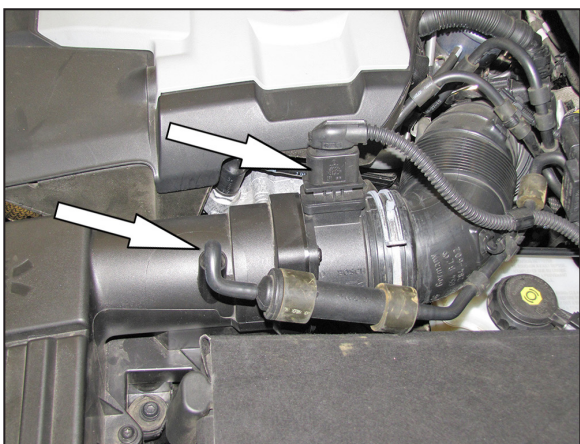

2. Disconnect the vacuum hose and mass air sensor electrical connections.



3. Remove the fresh air intake scoop lid as shown.



4. Disconnect the fresh air tube from the air filter housing and then remove the tube from the vehicle.



5. Remove the two bolts securing the fresh air intake scoop to the core support and then remove the scoop from the vehicle.

NOTE: The bolts are not visible in the picture.

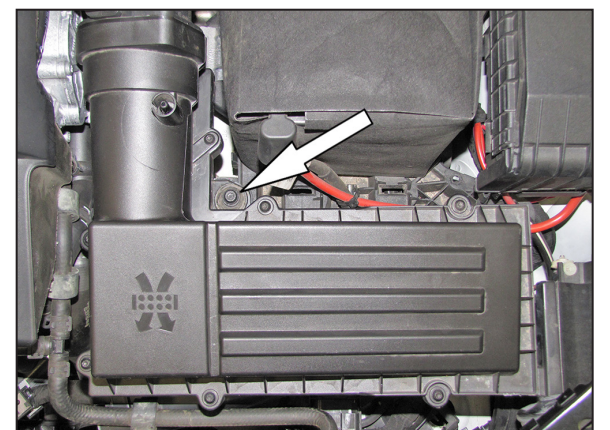

6. Loosen the bolt that secures the air filter housing to the vehicle.

NOTE: This bolt does not come out of the grommet.



7. Release the spring clamp securing the intake tube to the mass air sensor and then remove the air filter housing and mass air sensor from the vehicle.

NOTE: The air filter housing is also secured by mounting posts and grommets.

NOTE: K&N Engineering, Inc., recommends that customers do not discard factory air intake.

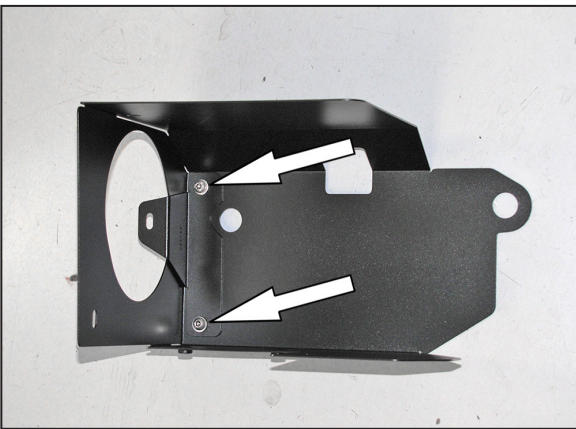

8. Install the provided tube mounting bracket (083132) onto the heat shield and secure with the provided hardware.

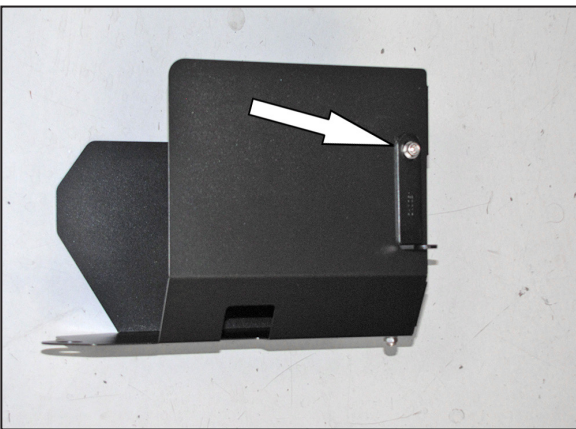

9. Install the heat shield mounting bracket (010051) onto the heat shield and secure with the provided hardware.

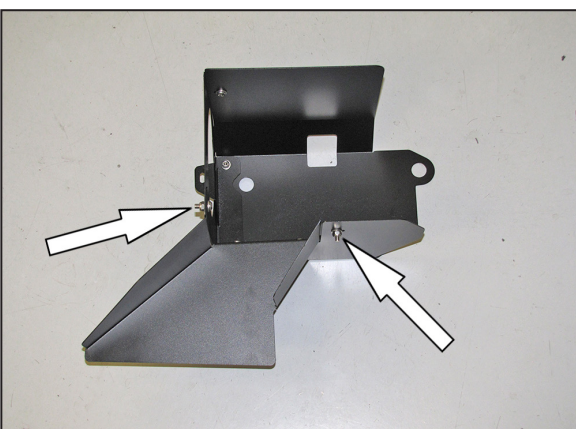

10. Install the provided fresh air intake scoop onto the heat shield and secure with the provided hardware.

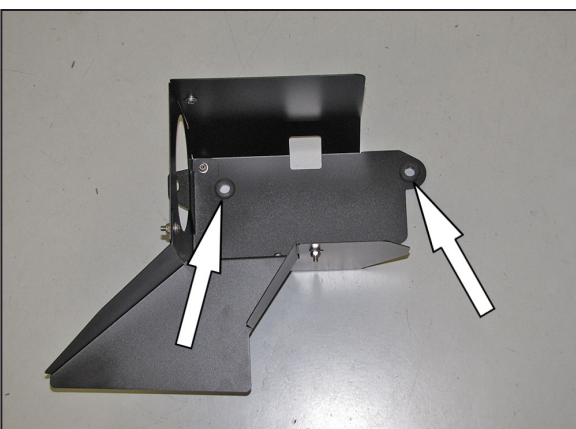

11. Install the two provided mounting grommets into the K&N® heat shield as shown.

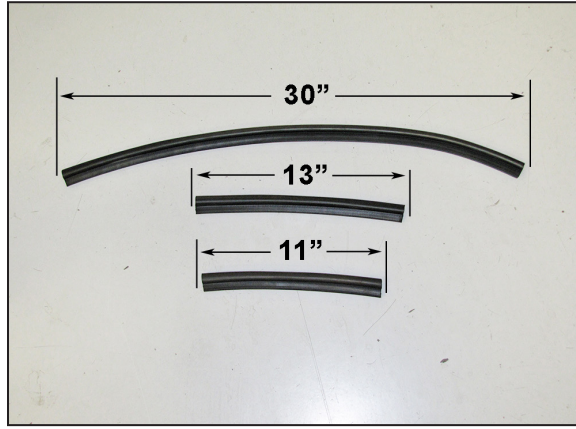

12. Cut the provided edge trim into three sections, one section should be 30" long, one section should be 13" long and one section should be 11" long.

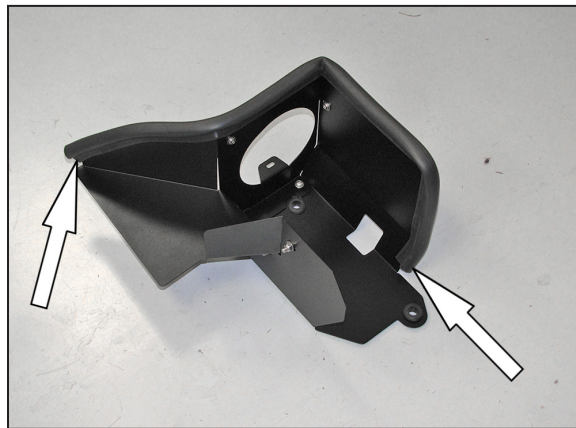

13. Install the 30" edge trim onto the heat shield as shown.

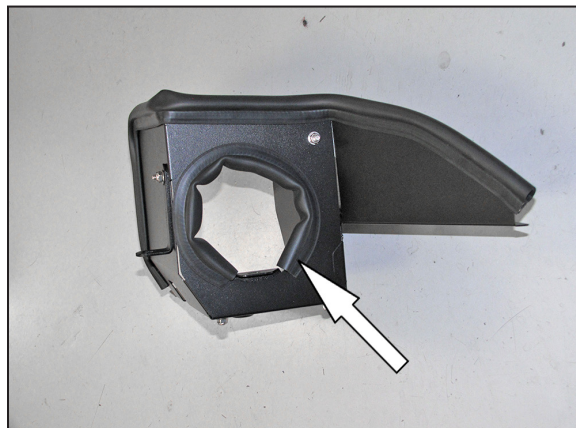

14. Install the 13" edge trim into the heat shield as shown.

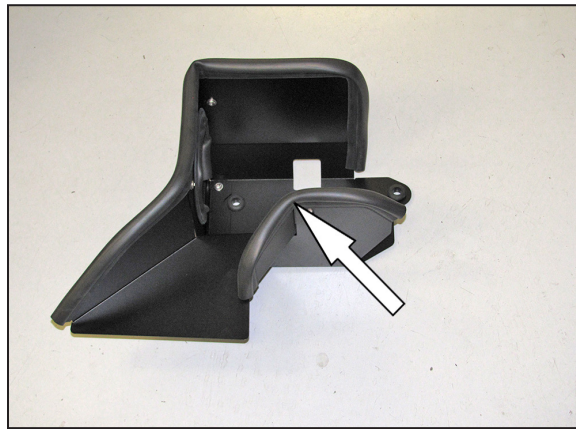

15. Install the 11" edge trim onto the heat shield as shown.



16. Set the heat shield into position on the air filter housing mounting studs and secure the bracket with the provided hardware.

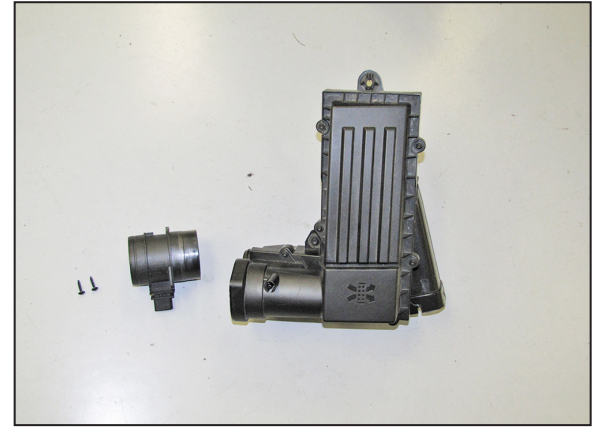

17. Remove the two screws securing the mass air sensor into the air filter housing and then remove the mass air sensor.



18. Install the provided coupler (087121) onto the mass air sensor and secure with provided hose clamp.

NOTE: Be sure to not install the hose too far onto the mass air sensor, the hump portion of the coupler should not be onto the sensor.



19. Install mass air sensor assembly onto the factory turbo inlet tube and secure with factory spring clamp.



20. Install the provided vacuum fitting into the K&N® intake tube as shown.

NOTE: Plastic NPT fittings are easy to cross thread. Install the vent fitting "hand" tight, then turn it two complete turns with a wrench.



21. Install the K&N® intake tube into coupler on the mass air sensor and into the heat shield. Secure the intake tube to the bracket with the provided hardware and to the coupler with the provided hose clamp.

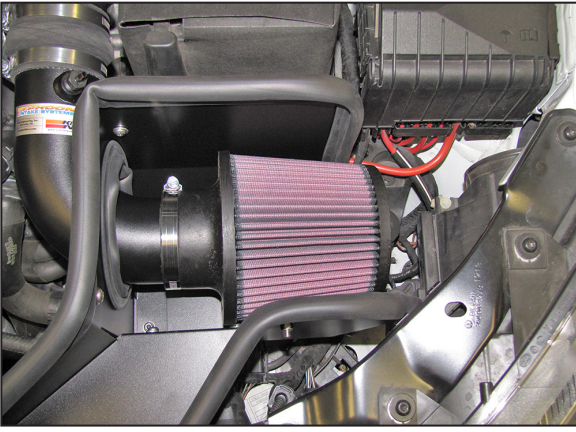

22. Install the K&N® air filter and secure with the provided hose clamp.
NOTE: Drycharger® air filter wrap; part # RX-4990DK is available to purchase separately.

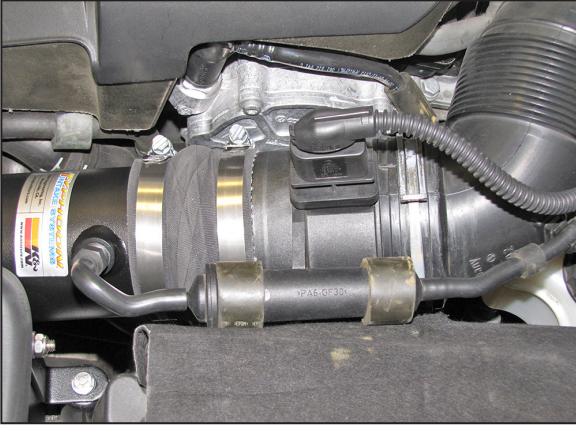

23. Reconnect the mass air sensor electrical connection and the vacuum line.



24. Reconnect the vehicle's negative battery cable. Double check to make sure everything is tight and properly positioned before starting the vehicle.

25. It will be necessary for all K&N® high flow intake systems to be checked periodically for realignment, clearance and tightening of all connections. Failure to follow the above instructions or proper maintenance may void warranty.

ROAD TESTING:

1. Start the engine with the transmission in neutral or park, and the parking brake engaged. Listen for air leaks or odd noises. For air leaks secure hoses and connections. For odd noises, find cause and repair before proceeding. This kit will function identically to the factory system except for being louder and much more responsive.

2. Test drive the vehicle. Listen for odd noises or rattles and fix as necessary.

3. If road test is fine, you can now enjoy the added power and performance from your kit.

4. K&N Engineering, Inc., requires cleaning the intake system's air filter element every 100,000 miles. When used in dusty or off-road environments, our filters will require cleaning more often. We recommend that you visually inspect your filter once every 25,000 miles to determine if the screen is still visible. When the screen is no longer visible some place on the filter element, it is time to clean it. To clean and re-oil, purchase our filter Recharger® service kit, part number 99-5050 or 99-5000 and follow the easy instructions.