



TYPHOON INTAKE SYSTEMS

INSTALLATION INSTRUCTIONS

69-9505T
AUDI
2009-13 A4
L4-2.0L

TOOLS NEEDED:

- Ratchet
- Extension
- 10mm Socket
- 7mm Socket
- Flat Blade Screwdriver
- Pliers
- T27 Torx
- T25 Torx
- 4mm Allen Wrench
- 3mm Allen Wrench

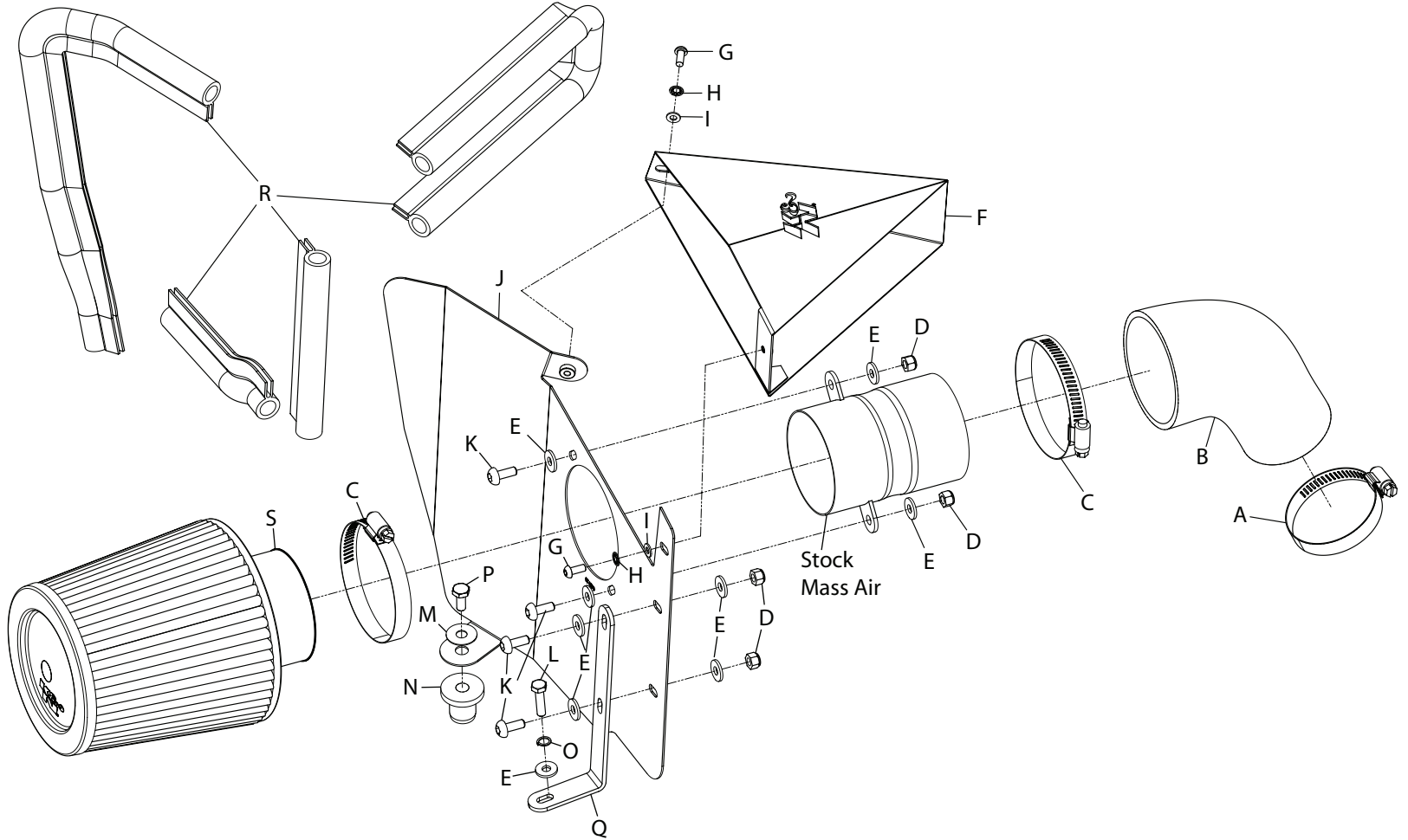

PARTS LIST:

| Description | Qty. | Part # | Description | Qty. | Part # | Description | Qty. | Part # |
|---------------------------------|------|--------|----------------------------------|------|--------|------------------------------|------|---------|
| A Hose Clamp #36 | 1 | 08530 | H Washer; 5MM Internal Star Cut | 2 | 07724 | O Washer; 1/4" Lock, ZN | 1 | 08198 |
| B Hose; 2.375"ID X 3.125"ID, | 1 | 08490 | I Washer; 5MM Flat, SS | 2 | 08212 | P Bolt; 3/8"-16x1-1/4"L SS | 1 | 07779 |
| C Hose Clamp #48 | 2 | 08601 | J Heat Shield | 1 | 074070 | Q Bracket; "L", STL, TK/PC | 1 | 083139 |
| D Nut; 6MM Nylock, Hexhead | 4 | 07512 | K Bolt; M6 X 1.00 X 16MM , Bttnd | 4 | 07730 | R Edge trim (48") | 1 | 102490 |
| E Washer; 1/4"IDx5/8"OD-SAE | 9 | 08275 | L Bolt; M6-1.00 X 25MM, SS | 1 | 07858 | S Air Filter | 1 | RF-1047 |
| F Heat Shield Scoop | 1 | 074071 | M Washer; 3/8" Flat SS | 1 | 08134 | | | |
| G Bolt; M5 - 0.8 X 12MM B/H, SS | 2 | 07734 | N Insert; 3/8-16x3/400x15/16L | 1 | 08163 | | | |

NOTE: FAILURE TO FOLLOW INSTALLATION INSTRUCTIONS AND NOT USING THE PROVIDED HARDWARE MAY DAMAGE THE INTAKE TUBE, THROTTLE BODY AND ENGINE.

TO START:

1. Turn off the ignition and disconnect the negative battery cable.
NOTE: Disconnecting the negative battery cable erases pre-programmed electronic memories. Write down all memory settings before disconnecting the negative battery cable. Some radios will require an anti-theft code to be entered after the battery is reconnected. The anti-theft code is typically supplied with your owner's manual. In the event your vehicles' anti-theft code cannot be recovered, contact an authorized dealership to obtain your vehicles anti-theft code.

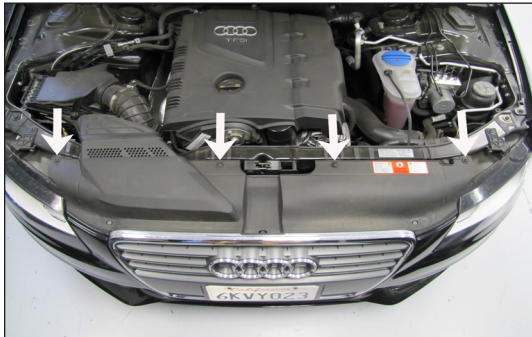

2. Remove the four screws which secure the front core support cover.
NOTE: These screws will be reused in a later step.



3. Pull up the rear of the cover then push towards the rear to unhook it from the grill. Then remove the cover from the vehicle.



4. Remove the two screws which secure the fresh air scoop to the core support.
NOTE: These screws will be reused in a later step.



5. Unsnap the fresh air scoop from the air box and then remove the scoop from the vehicle.

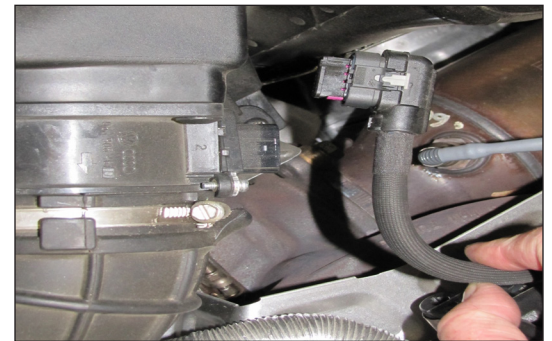

6. Disconnect the mass air sensor electrical connection.

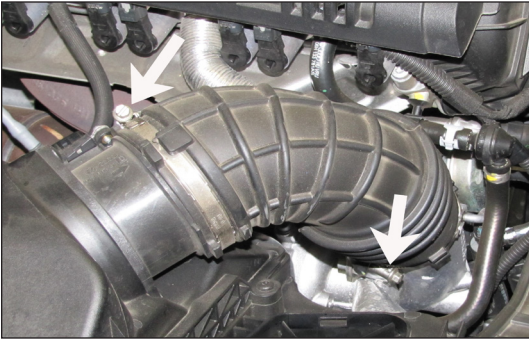

7. Loosen the two hose clamps which secure the stock intake tube to the turbo inlet and factory air box, then remove the intake tube from the vehicle.



8. Pull up the air box and remove it from the vehicle.

NOTE: K&N Engineering, Inc., recommends that customers do not discard factory air intake.

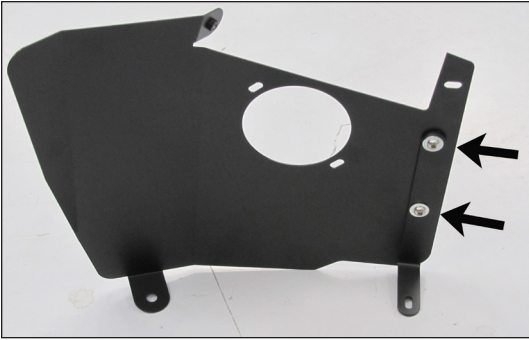

9. Install the heat shield mounting bracket (083139) onto the heat shield as shown.

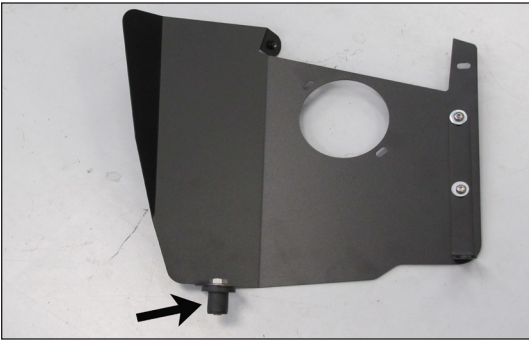

10. Install the inserted nut onto the heat shield using the provided hardware as shown.

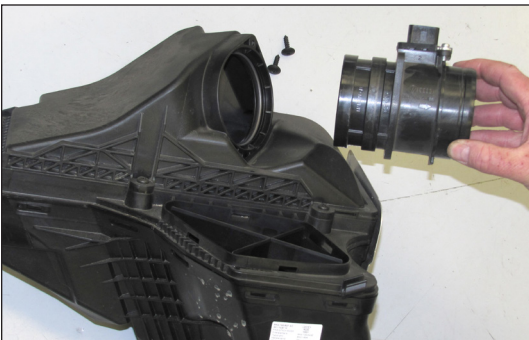

11. Remove the two screws securing the mass air sensor to the air box and then remove the mass air sensor from the air box.

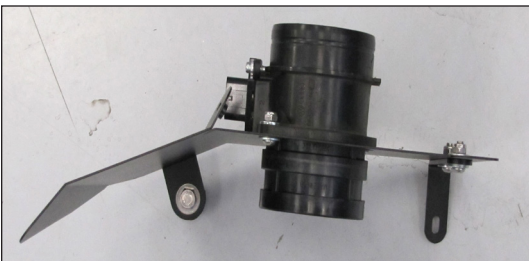

12. Install the mass air sensor into the heat shield as shown and secure with the provided hardware.

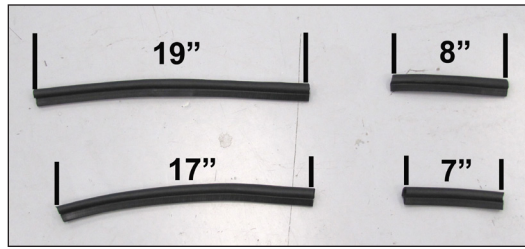

13. Cut the provided edge trim into the four separate lengths as shown. One length will be 19" long, one length will be 17" long, one length will be 8" long and the shortest length will be 7".

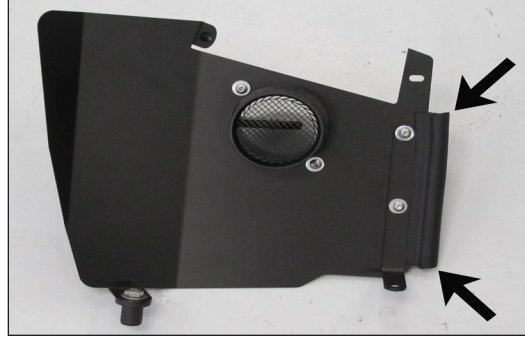

14. Install the 7" section of edge trim onto the heat shield as shown.

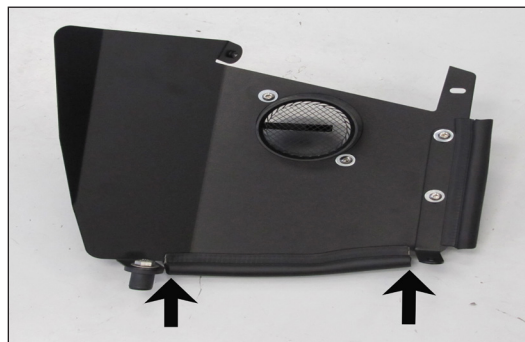

15. Install the 8" section of edge trim onto the heat shield as shown.

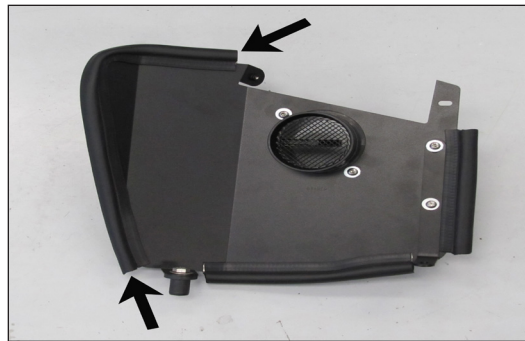

16. Install the 17" section of edge trim onto the heat shield as shown.

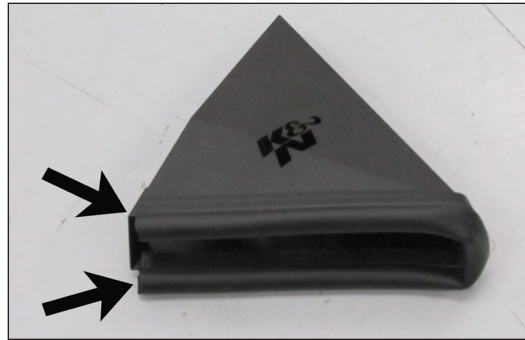

17. Install the 19" section of edge trim onto the fresh air scoop as shown.

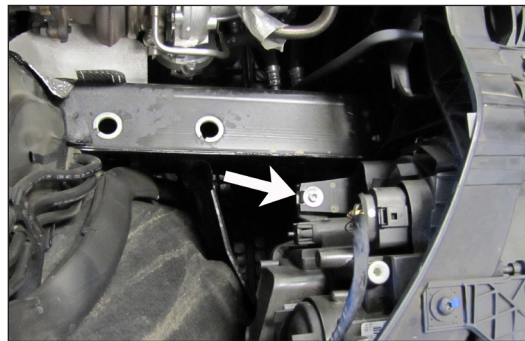

18. Remove the headlamp mounting bolt shown.

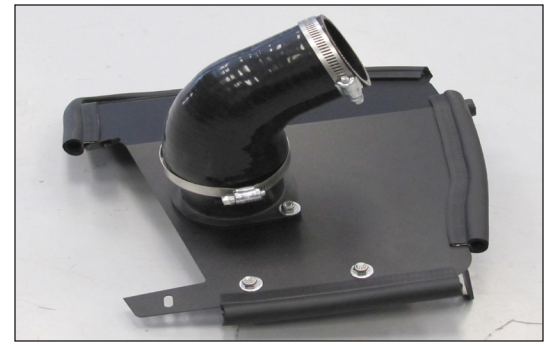

19. Install the silicone hose (08490) onto the mass air sensor as shown and secure with the provided hose clamp.

NOTE: Do not completely tighten at this time.

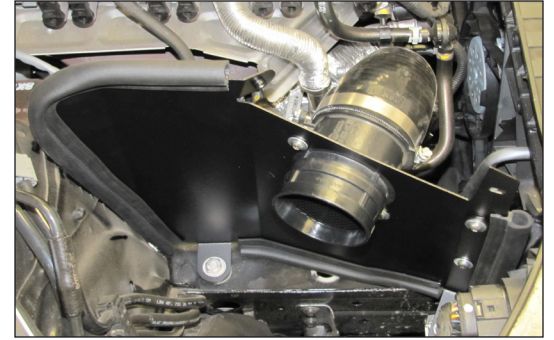

20. Set the heat shield assembly into position on the inner fender while installing the silicone hose onto the turbo inlet. Secure the heat shield with the provided hardware and secure the silicone hose with the provided hose clamps.

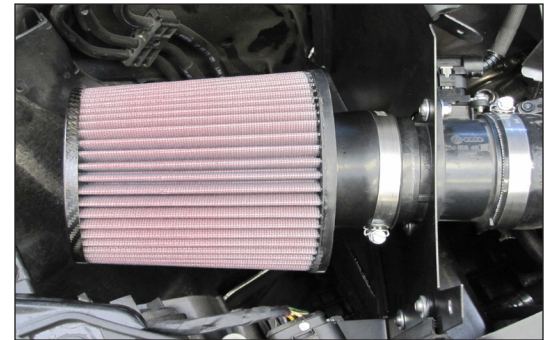

21. Install the K&N® air filter onto mass air sensor and secure with the provided hose clamp.

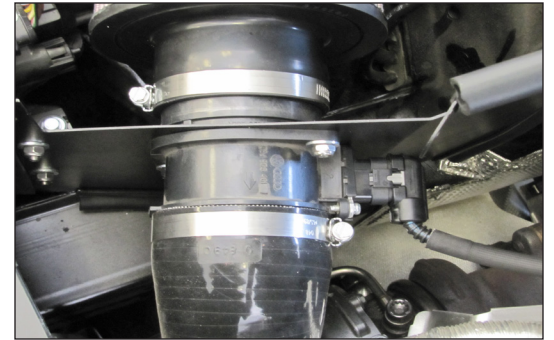

22. Reconnect the mass air sensor electrical connection.

NOTE: Due to manufacturing tolerances, it may be necessary to unclip the mass air sensor electrical harness from the plastic covering to provide adequate slack.

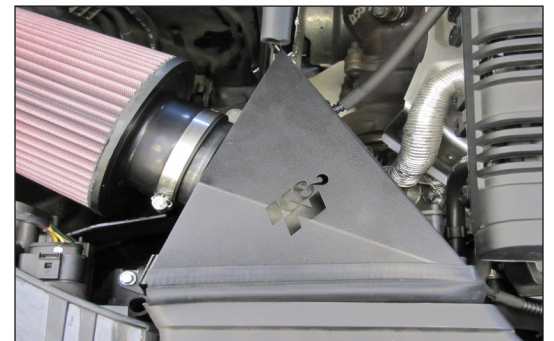

23. Using the provided hardware, secure the fresh air scoop to the heat shield as shown.

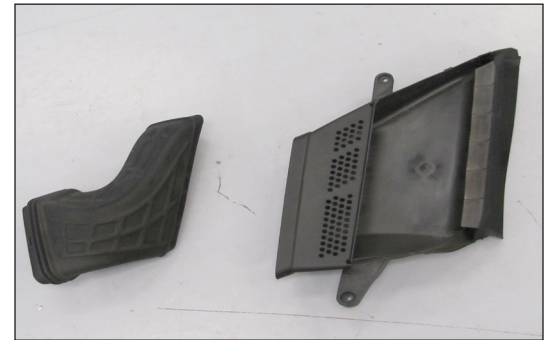

24. Separate the fresh air bellows from the fresh air scoop as shown.

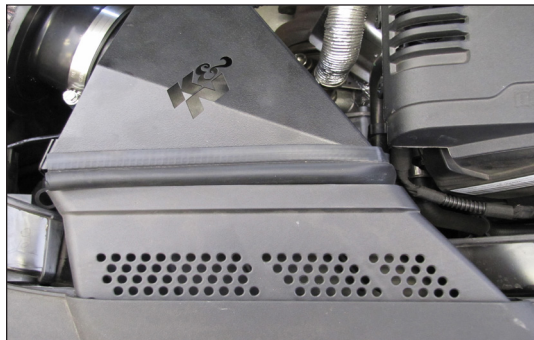

25. Reinstall the factory fresh air scoop onto the core support as shown using the factory hardware.

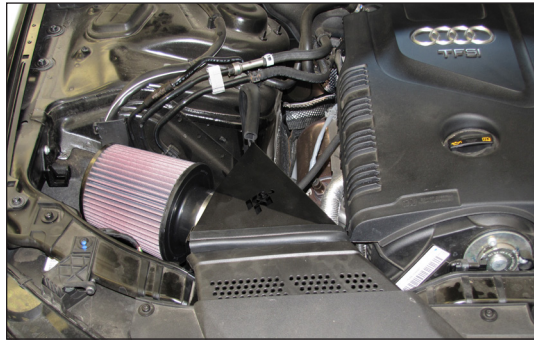

26. Reinstall the core support cover and secure using the factory hardware.

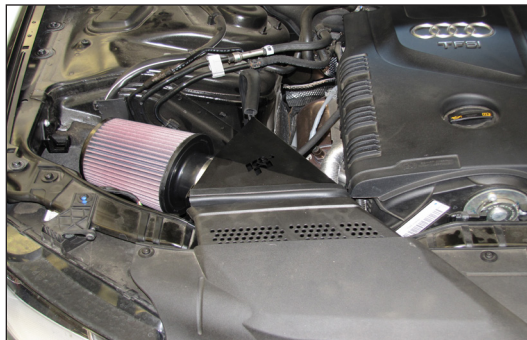

27. Reconnect the vehicle's negative battery cable. Double check to make sure everything is tight and properly positioned before starting the vehicle.

28. It will be necessary for all K&N® high flow intake systems to be checked periodically for realignment, clearance and tightening of all connections. Failure to follow the above instructions or proper maintenance may void warranty.

ROAD TESTING:

1. Start the engine with the transmission in neutral or park, and the parking brake engaged. Listen for air leaks or odd noises. For air leaks secure hoses and connections. For odd noises, find cause and repair before proceeding. This kit will function identically to the factory system except for being louder and much more responsive.

2. Test drive the vehicle. Listen for odd noises or rattles and fix as necessary.

3. If road test is fine, you can now enjoy the added power and performance from your kit.

4. K&N Engineering, Inc., requires cleaning the intake system's air filter element every 100,000 miles. When used in dusty or off-road environments, our filters will require cleaning more often. We recommend that you visually inspect your filter once every 25,000 miles to determine if the screen is still visible. When the screen is no longer visible some place on the filter element, it is time to clean it. To clean and re-oil, purchase our filter Recharger® service kit, part number 99-5050 or 99-5000 and follow the easy instructions.