



INSTALLATION INSTRUCTIONS

57-9027 TOYOTA 2005-06 SEQUOIA / TUNDRA V8-4.7L

NOTE: This kit was not designed to fit vehicles with a body lift.

TOOLS NEEDED:

- 5/8" wrench
- 9/16" wrench
- 3/16" drill bit
- 10mm socket extension
- flat blade screwdriver
- phillips screwdriver
- pliers
- ratchet
- drill
- tin snips
- sharp knife

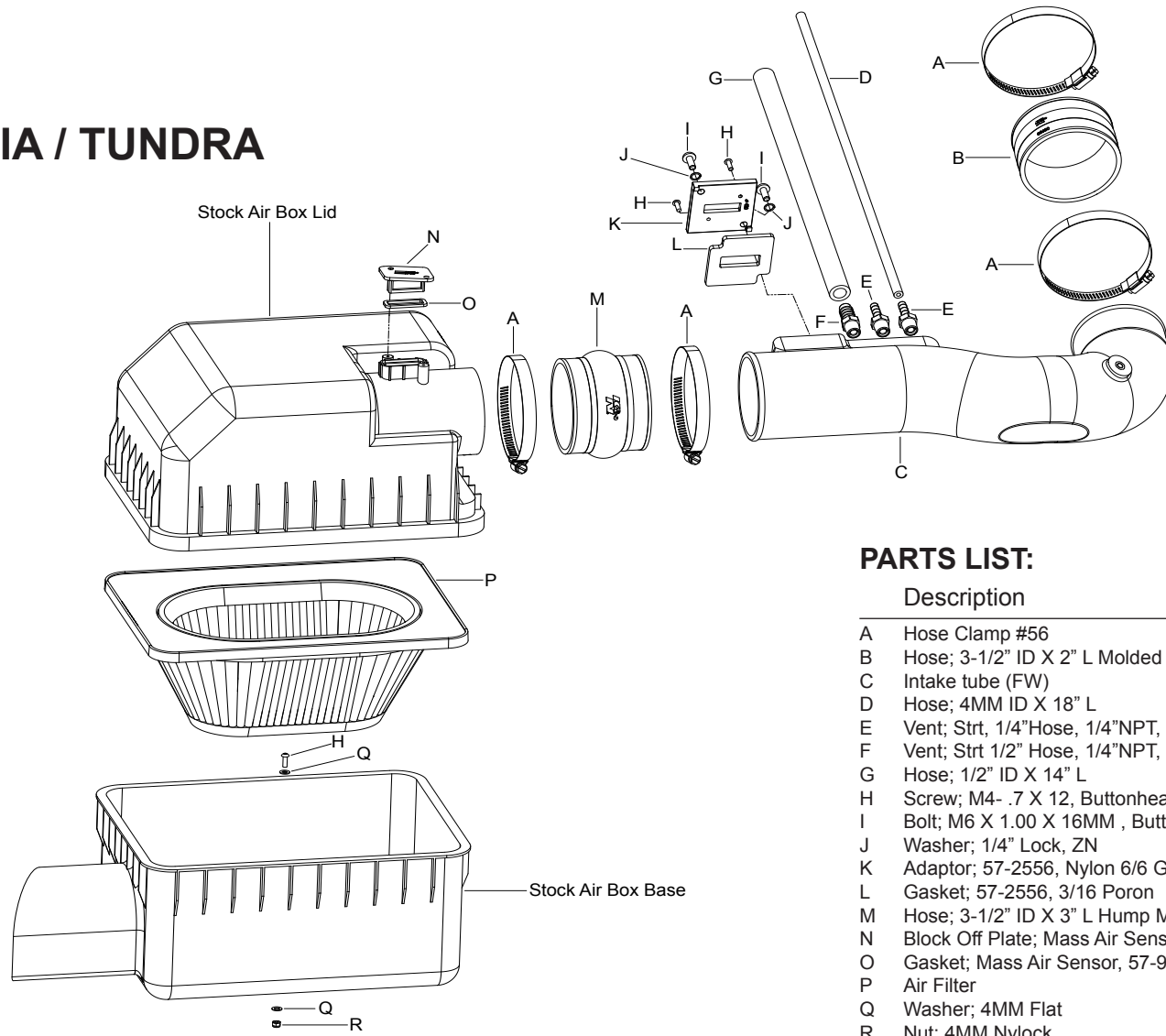

PARTS LIST:

Description	Qty.	Part #
A Hose Clamp #56	4	08620
B Hose; 3-1/2" ID X 2" L Molded	1	08630
C Intake tube (FW)	1	087195
D Hose; 4MM ID X 18" L	1	08153
E Vent; Strt, 1/4" Hose, 1/4" NPT, Plas	2	08046
F Vent; Strt 1/2" Hose, 1/4" NPT, Plas	1	080022
G Hose; 1/2" ID X 14" L	1	08402
H Screw; M4- .7 X 12, ButtonheadSS	3	07726
I Bolt; M6 X 1.00 X 16MM, Buttonhead, SS	2	07730
J Washer; 1/4" Lock, ZN	2	08198
K Adaptor; 57-2556, Nylon 6/6 GF, Black	1	21515
L Gasket; 57-2556, 3/16 Poron	1	09069
M Hose; 3-1/2" ID X 3" L Hump Molded	1	084057
N Block Off Plate; Mass Air Sensor, 57-9027	1	21508
O Gasket; Mass Air Sensor, 57-9027	1	09076
P Air Filter	1	E-3034
Q Washer; 4MM Flat	2	08278
R Nut; 4MM Nylock	1	07501

NOTE: FAILURE TO FOLLOW INSTALLATION INSTRUCTIONS AND NOT USING THE PROVIDED HARDWARE MAY DAMAGE THE INTAKE TUBE, THROTTLE BODY AND ENGINE.

TO START:

1. Turn the ignition OFF and disconnect the vehicle's negative battery cable.

NOTE: Disconnecting the negative battery cable erases pre-programmed electronic memories. Write down all memory settings before disconnecting the negative battery cable. Some radios will require an anti-theft code to be entered after the battery is reconnected. The anti-theft code is typically supplied with your owner's manual. In the event your vehicles' anti-theft code cannot be recovered, contact an authorized dealership to obtain your vehicles anti-theft code.

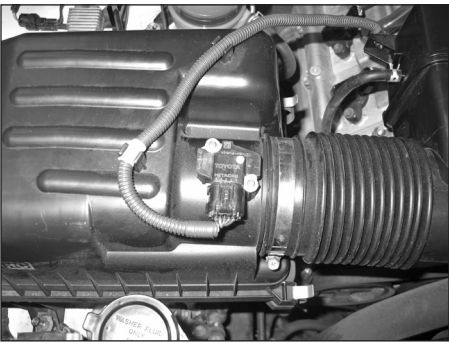

2. Disconnect the mass air sensor electrical connection, then release the mass air sensor wiring harness from the air box.



3. Remove the two nuts that fasten the throttle body cover, then remove the throttle body cover.

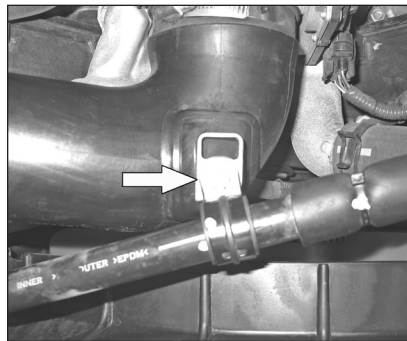

4. Remove the bolt that fastens the A/C mounting clamp.

NOTE: Bolt will be re-used, do not discard.

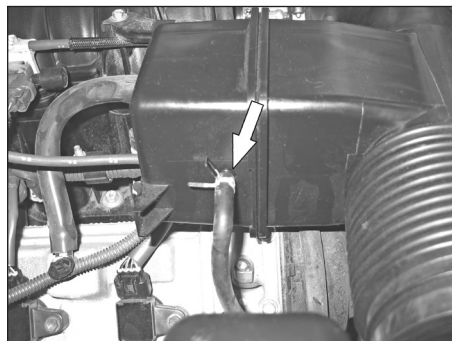

5. Release the spring clamp, then remove the P/S pressure switch vent hose from the intake tube.

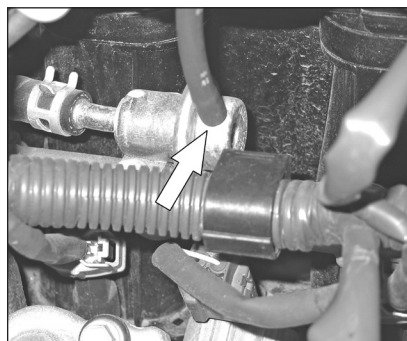

6. Disconnect the fuel pressure regulator vent line from the fuel pressure regulator.

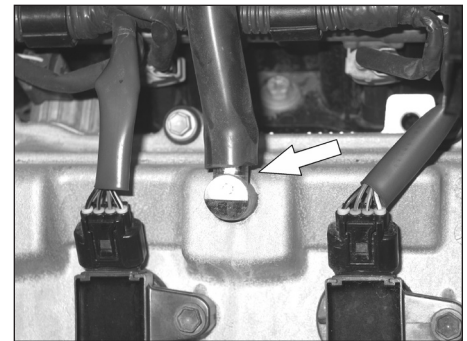

7. Disconnect the crank case vent hose from the valve cover.

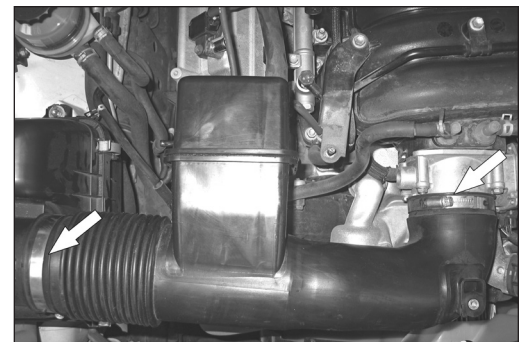

8. Loosen the hose clamps that fasten the stock intake tube to the throttle body and air box.



9. Remove the stock intake tube.

NOTE: K&N Engineering, Inc., recommends that customers do not discard factory air intake.



10. Install the three provided 1/4" npt fittings into the K&N® intake tube as shown.

NOTE: Plastic NPT fittings are easy to cross thread. Install the vent fitting "hand" tight, then turn it two complete turns with a wrench.



11. Install the provided gasket onto the K&N® mass air sensor adapter.

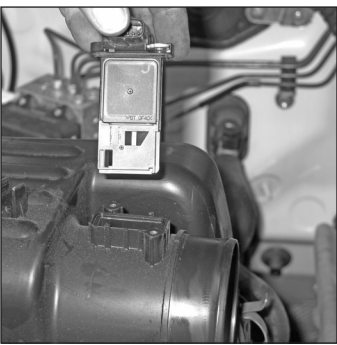

12. Remove the two screws that fasten the mass air sensor to the stock air box, then remove the mass air sensor.

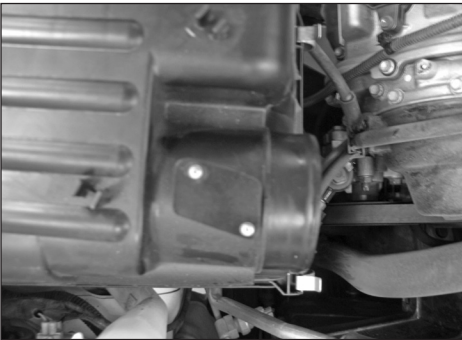

13. Install the provided mass air sensor block off plate onto the stock air box.

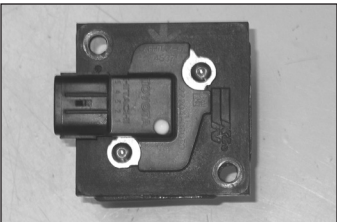

14. Install the mass air sensor into the K&N® mass air sensor adapter and fasten with the provided hardware.



15. Install the mass air sensor assembly into the K&N® intake tube and fasten with the provided hardware.



16. Install the provided silicone hose onto the throttle body and fasten using the provided hose clamp.

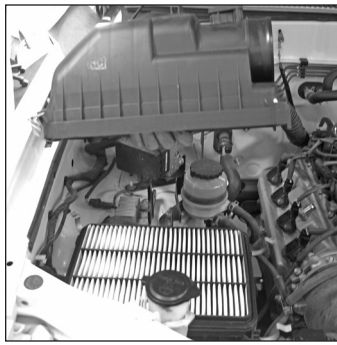

17. Release the four upper air box retaining clips, then remove the upper air box.



18. Remove the stock air filter, then remove the three bolts that secure the lower air box to the inner fender.



19. Remove the lower air box.

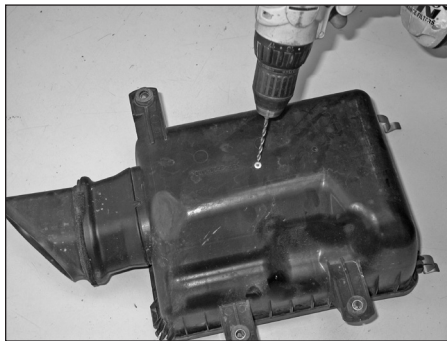

20. Drill out the center of the rivet that fastens the fresh air duct to the lower air box, then remove the rivet.



21. Remove the fresh air duct from the lower air box.

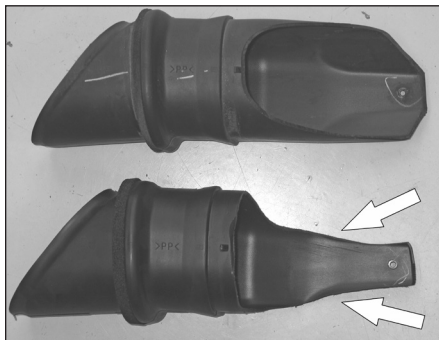

22. Trim both sides of the fresh air duct as shown in the photographs.



23. Re-install the fresh air duct into the lower air box and fasten with the provided hardware.



24. Re-install the lower air box into its stock location and fasten with the stock hardware.



25. Install the K&N® air filter into the lower air box.



26. Install the upper air box and fasten with the stock retaining clips.



27. Install the provided silicone hump hose onto the air box and fasten with the provided hose clamp.



28. Install the K&N® intake tube into the silicone hoses previously installed onto the throttle body and air box.

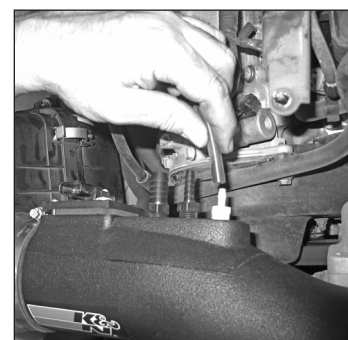

29. Install the provided 4mm silicone hose onto the npt vent fitting previously installed onto the K&N® intake tube.

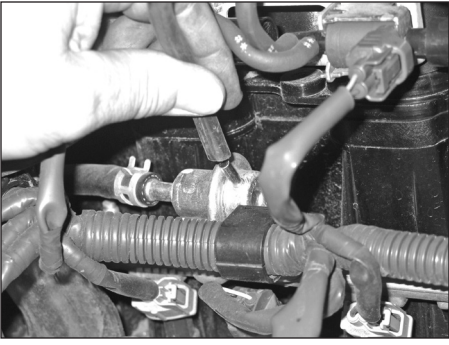

30. Connect the remaining open end of the 4mm silicone hose to the fuel pressure regulator vent port.



31. Connect the P/S pressure switch vent hose to the npt fitting previously installed into the K&N® intake tube, then fasten using the stock spring clamp.

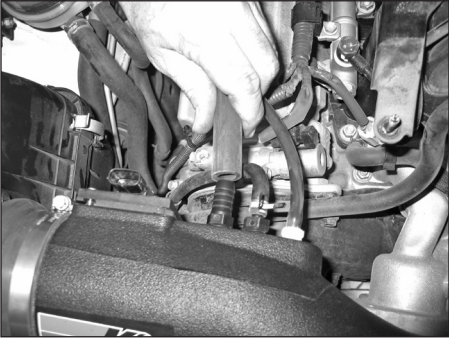

32. Install the provided crank case vent hose onto the npt fitting previously installed into the K&N® intake tube.

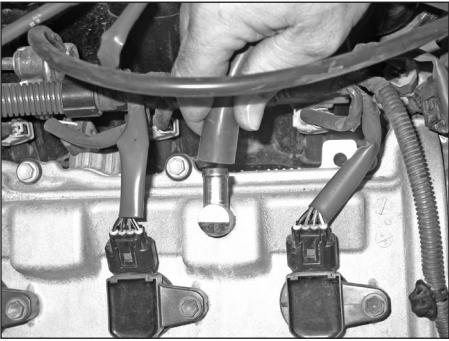

33. Install the remaining open end of the crank case vent hose onto the stock fitting on the valve cover.

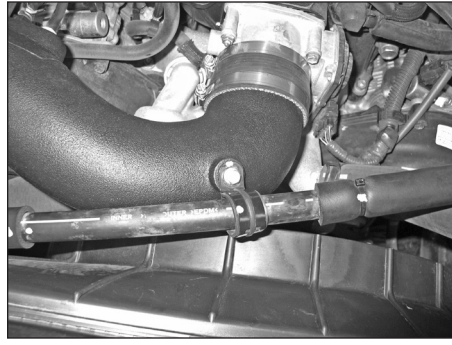

34. Fasten the A/C hose mounting clamp to the K&N® intake tube using the stock mounting bolt removed in step #4.



35. Install the stock throttle body cover and fasten using the stock nuts.

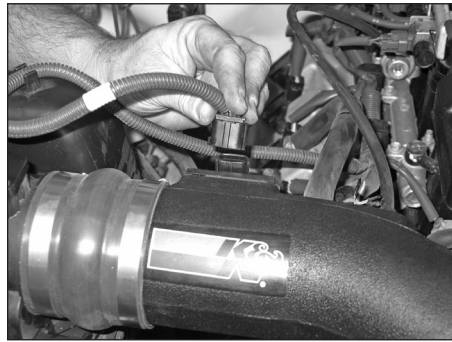

36. Re-connect the mass air sensor electrical connection.

37. Secure the mass air sensor wiring harness to the intake tube with the tie wrap and bolt provided.

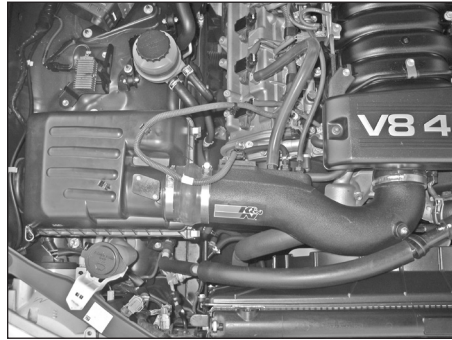

38. Reconnect the vehicle's negative battery cable. Double check to make sure everything is tight and properly positioned before starting the vehicle.

39. The C.A.R.B. exemption sticker, (attached), must be visible under the hood, so the emissions inspector can see it when the vehicle is required to be tested for emissions. California requires testing every two years, other states may vary.

40. It will be necessary for all K&N® high flow intake systems to be checked periodically for realignment, clearance and tightening of all connections. Failure to follow the above instructions or proper maintenance may void warranty.

ROAD TESTING:

1. Start the engine with the transmission in neutral or park, and the parking brake engaged. Listen for air leaks or odd noises. For air leaks secure hoses and connections. For odd noises, find cause and repair before proceeding. This kit will function identically to the factory system except for being louder and much more responsive.

2. Test drive the vehicle. Listen for odd noises or rattles and fix as necessary.

3. If road test is fine, you can now enjoy the added power and performance from your kit.

4. K&N Engineering, Inc., suggests checking the air filter element periodically for excessive dirt build-up. When the element becomes covered in dirt (or once a year), service it according to the instructions on the Recharger® service kit, part number 99-5050 or 99-5000.