



# INSTALLATION INSTRUCTIONS

**57-6005**

**NISSAN**

**1999-04 Xterra / Frontier**

**V6-3.3L**

**NOTE:** This kit was not designed to fit vehicles with a body lift.

**TOOLS NEEDED:**

- Ratchet
- 3" Extension
- 12" Extension
- 8mm Socket or Nut Driver
- 10mm Socket
- 10mm Wrench
- 7/16" Open Wrench
- Pliers
- Side Cutters

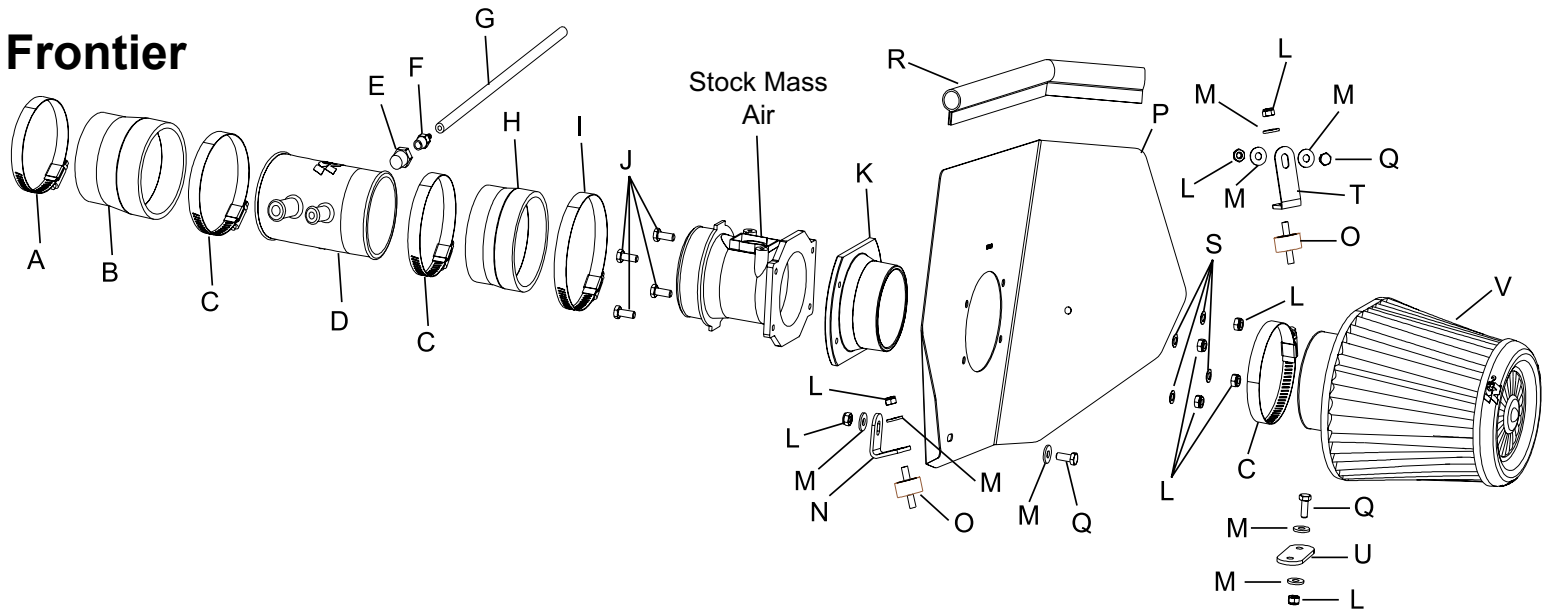

**PARTS LIST:**

Description	Qty.	Part #	Description	Qty.	Part #	Description	Qty.	Part #
A Hose Clamp, #44	1	08577	I Hose Clamp, #56	1	08620	Q 6mm Hex Bolt, 16mm L.	3	07703
B Silicone Step Hose	1	08096	J 6mm Hex Bolt, 25mm L.	4	07704	R Edge trim, 14"L	1	102475
C Hose Clamp, #48	3	08601	K Mass Air Adapter	1	21506	S 6mm Wave Washer	4	08174
D Intake Tube	1	087017	L 6mm Nylock Nut	9	07553	T Bracket, "L"	1	070662
E Plug, 1/8" NPT	1	08178	M 1/4" Flat Washer	8	08275	U Bracket, "Flat"	1	070005
F Vent, Straight	1	087016	N Bracket, "V"	1	070004	V <a href="#">Air Filter</a>	1	RX-4750
G Hose, 4mm x 12"L.	1	08147	O 6mm Rubber Mounted Stud	2	07027			
H Silicone Step Hose	1	084031	P Heat Shield	1	07440			

**NOTE: FAILURE TO FOLLOW INSTALLATION INSTRUCTIONS AND NOT USING THE PROVIDED HARDWARE MAY DAMAGE THE INTAKE TUBE, THROTTLE BODY AND ENGINE.**

**TO START:**

1. Turn off the ignition and disconnect the negative battery cable.

**NOTE: Disconnecting the negative battery cable erases pre-programmed electronic memories. Write down all memory settings before disconnecting the negative battery cable. Some radios will require an anti-theft code to be entered after the battery is reconnected. The anti-theft code is typically supplied with your owner's manual. In the event your vehicles' anti-theft code cannot be recovered, contact an authorized dealership to obtain your vehicles anti-theft code.**



2. Disconnect the mass air sensor electrical connection.

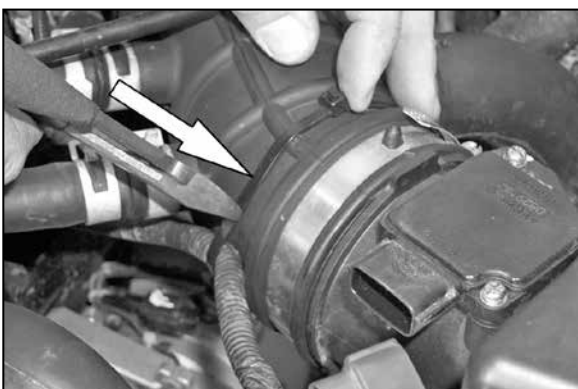

3. Lift up on the release tab to remove the factory zip-tie, as this will be reused in a later step.

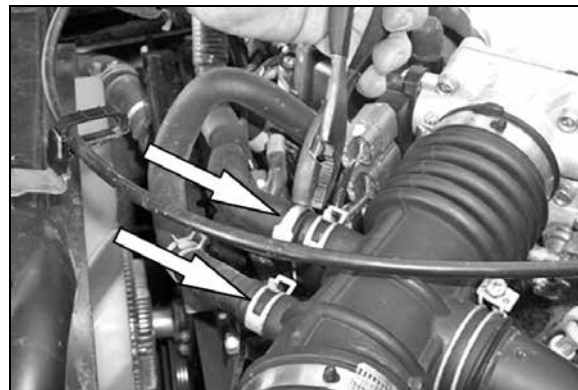

4. Squeeze the two hose clamps and slide back using pliers.



5. Remove the two hoses from the intake tube.



6. Disconnect the cruise control cable bracket using a 10mm socket.  
**NOTE: Some vehicles do not have this cable.**



7. Loosen clamp on the resonator tube using a 10mm socket.

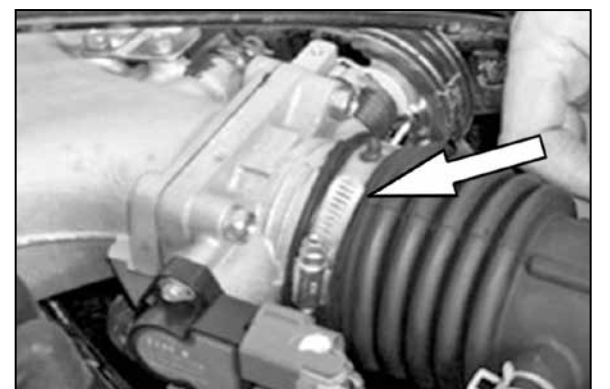

8. Loosen clamp at the throttle body using an 8mm socket.



9. Unlatch the four clips on the air filter housing and remove the top assembly.



10. Remove the air temp sensor by pulling in an upward direction as shown.

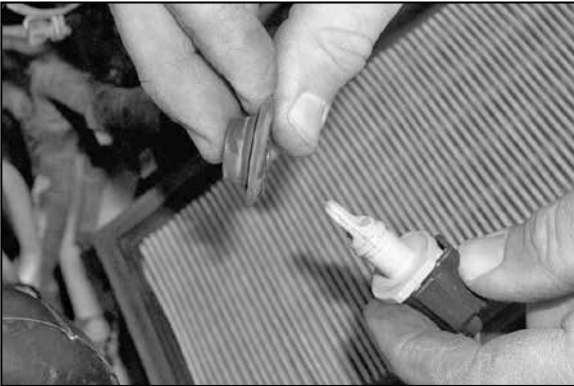

11. Remove rubber grommet from air temp sensor.

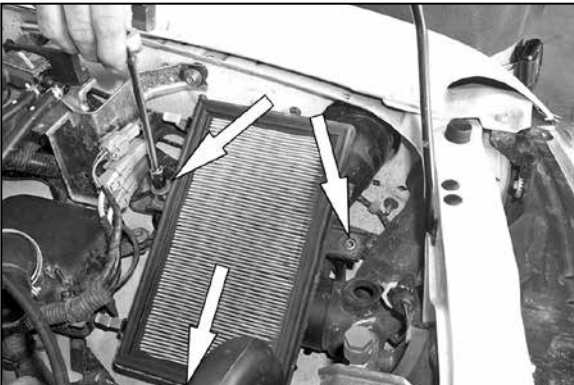

12. Remove the three bolts that secure the lower air filter housing using an 8mm socket.



13. Remove the lower air filter housing as shown  
**NOTE: K&N Engineering, Inc., recommends that customers do not discard factory air intake.**



14. Remove the front support bracket using a 10mm socket.



15. Remove bolt from front of resonator using a 10mm socket.  
**NOTE: Bolt will be re-used**



16. Remove the front resonator assembly as shown.

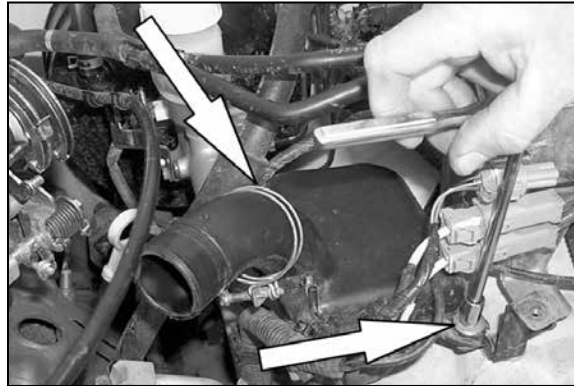

17. Remove the two bolts on rear resonator box using a 10mm socket.



18. Using pliers, remove the wire loom clip.



19. Remove the resonator box as shown.



20. Loosen hose clamp using a 10mm socket and remove air duct tube from mass air sensor.



21. Remove the four bolts from mass air sensor housing using a 10mm socket and detach from airbox.

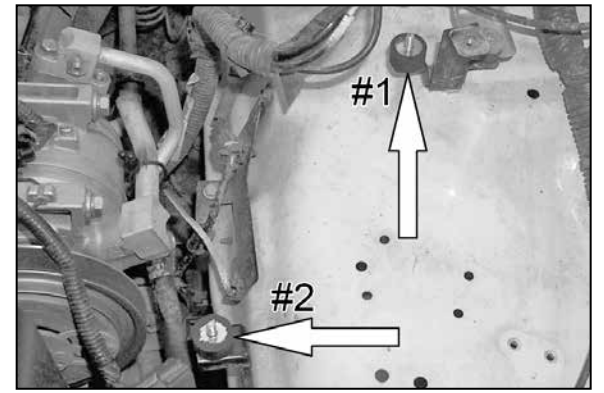

22. Install the two rubber mount studs in stock bracket.

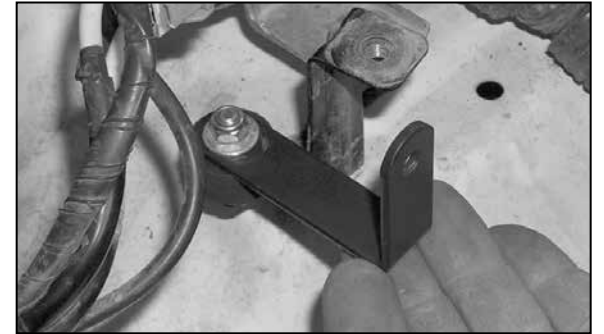

23. Attach slotted end of bracket, 070662, onto rubber mount, #1, (see picture on step #22), with washer and lock nut. Do not tighten completely.



24. Attach the bracket, 070004, onto the front rubber mount, #2, (see picture on step #22). Do not tighten completely at this time.



25. Install silicone hose, (08096), and hose clamp #44 onto the throttle body and tighten.



26. Install hose clamp #48 and the intake tube onto the silicone hose on the throttle body. Do not tighten completely.



27. Install edge trim seal onto heat shield as shown.  
**NOTE: Some trimming may be necessary to adhere best fit.**

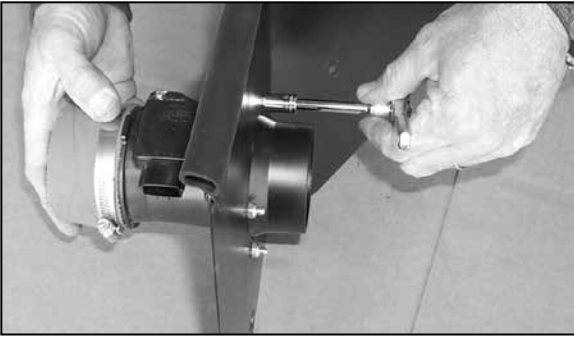

28. Install the silicone hose (084031) and hose clamp #56 onto the mass air sensor then assemble the mass air sensor and filter adapter onto the heat shield using the supplied hardware, 4 -washers, 4 - 25mm bolts and 4 - nylock nuts.



29. Install heat shield assembly, using hose clamp #48 sliding over intake tube.

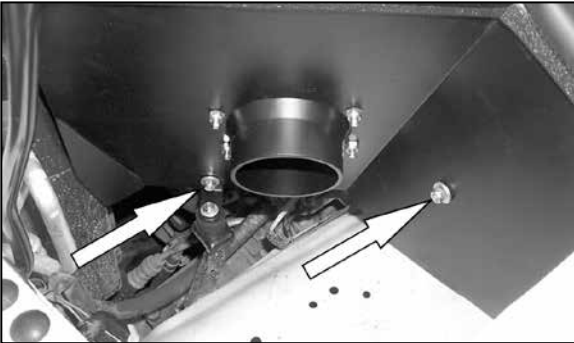

30. Align holes with brackets and attach using hardware provided. Do not tighten completely. **NOTE: brackets go on engine side of heat shield.**



31. Align intake tube for best fit then tighten hose clamps. Reattach the two hoses onto the intake tube.

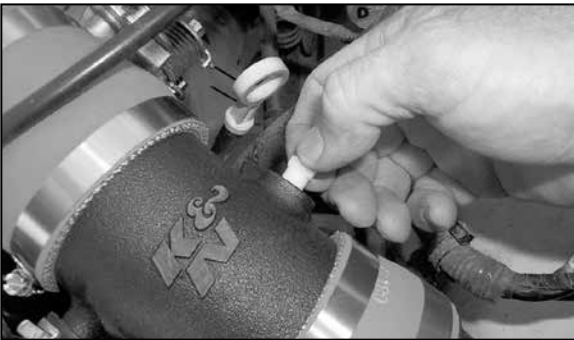

32. On vehicles **NOT** equipped with a map / baro switch solenoid valve, install the provided plug, (08178) onto the intake tube. **NOTE: Plastic NPT fittings are easy to cross thread. Install the vent fitting "hand" tight, then turn it two complete turns with a wrench.**

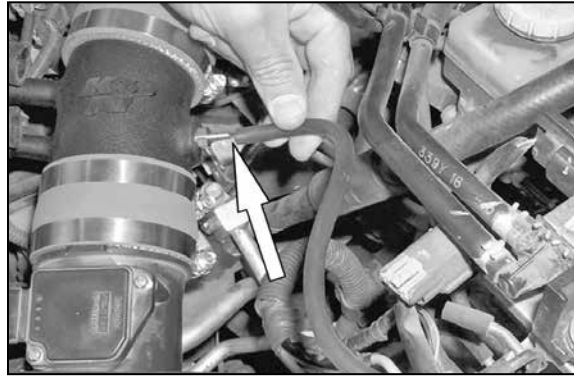

33. On vehicles equipped with a map/baro switch solenoid valve, install vent (087016) and attach hose to the intake tube.

34. Tighten all brackets and hardware using 8mm and 10mm socket.



35. Reconnect the mass air sensor electrical connection.

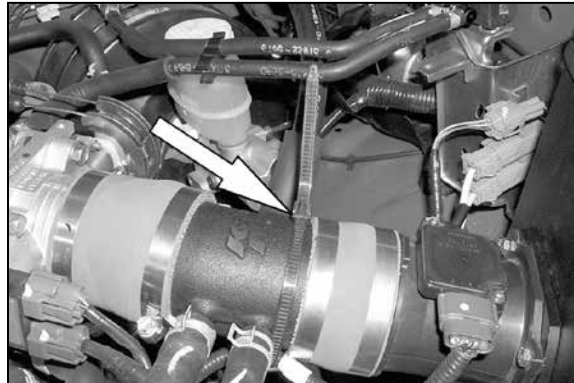

36. Using the zip-tie removed in step 3, secure the mass air sensor electrical connection to the K&N® intake tube as shown.



37. Reconnect the throttle cable bracket using the flat bracket, two washers, 10mm bolt, nylock nut and the stock bolt. Tighten completely.



38. Insert air temp sensor into base of air filter.

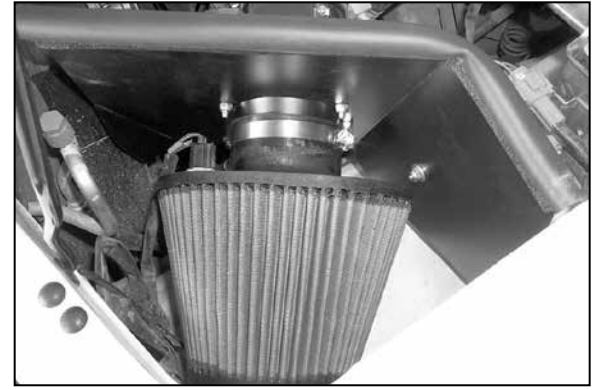

39. Install RX-4750 air filter element and secure with hose clamp using an 8mm socket or nut driver. **NOTE: Drycharger® air filter wrap; part # RF-1042DK is available to purchase separately.**



40. Reconnect the vehicle's negative battery cable. Double check to make sure everything is tight and properly positioned before starting the vehicle.

41. The C.A.R.B. exemption sticker, (attached), must be visible under the hood so that an emissions inspector can see it when the vehicle is required to be tested for emissions. California requires testing every two years, other states may vary.

42. It will be necessary for all K&N® high flow intake systems to be checked periodically for realignment, clearance and tightening of all connections. Failure to follow the above instructions or proper maintenance may void warranty.

#### ROAD TESTING:

1. Start the engine with the transmission in neutral or park, and the parking brake engaged. Listen for air leaks or odd noises. For air leaks secure hoses and connections. For odd noises, find cause and repair before proceeding. This kit will function identically to the factory system except for being louder and much more responsive.

2. Test drive the vehicle. Listen for odd noises or rattles and fix as necessary.

3. If road test is fine, you can now enjoy the added power and performance from your kit.

4. K&N Engineering, Inc., requires cleaning the intake system's air filter element every 100,000 miles. When used in dusty or off-road environments, our filters will require cleaning more often. We recommend that you visually inspect your filter once every 25,000 miles to determine if the screen is still visible. When the screen is no longer visible some place on the filter element, it is time to clean it. To clean and re-oil, purchase our filter Recharger® service kit, part number 99-5050 or 99-5000 and follow the easy instructions.