



INSTALLATION INSTRUCTIONS

57-3045

CHEVROLET/PONTIAC

2000-05 IMPALA / MONTE CARLO
V6-3.8L

2004-05 IMPALA / MONTE CARLO
V6-3.8L S/C

1999-03 GRAND PRIX

V6-3.8L

1999-03 GRAND PRIX

V6-3.8L S/C

TOOLS NEEDED:

Ratchet
Extension
7mm Socket
8mm Socket
10mm Socket
13mm Socket
10mm Wrench
Flat Blade Screw Driver
#27 Torx

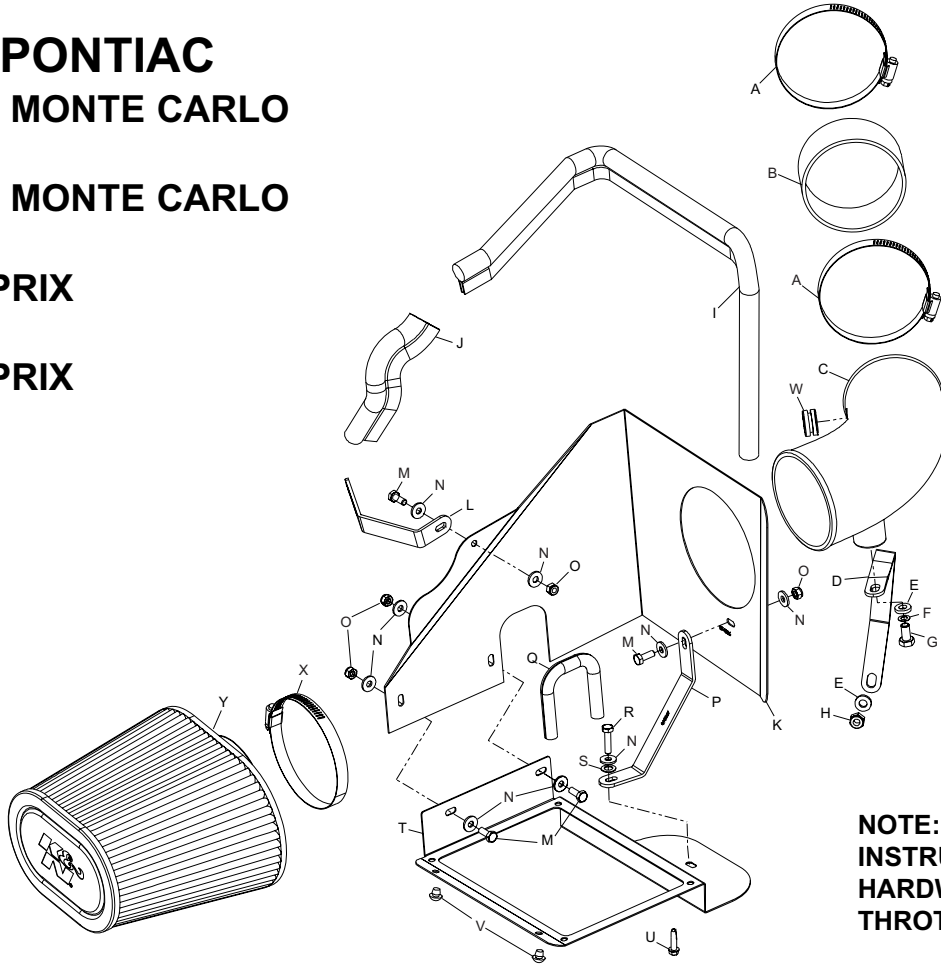

PARTS LIST:

Desc.	QTY.	Part #
A hose clamp #60	2	08628
B silicone hose; black	1	08621
C intake tube (DW)	1	087119
D bracket large "C"	1	07199
E flat washer;5/16"idx5/8"od	2	08276
F wave washer 8mm	1	08239
G hex bolt;8mm-1.75x16mm	1	07844
H nut; 8mm nylock	1	07542
I edge trim 30"	1	102489
J edge trim 9"	1	102465
K heat shield	1	074024
L bracket small "C"	1	010056
M hex bolt;6mm-1.00x16mm	4	07703
N flat washer;1/4"idx5/8"od	9	08275
O nut; 6mm nylock	4	07553
P bracket medium "C"	1	010057
Q edge trim	1	102452
R hex bolt;6mm-1.00x25mm	1	07704
S wave washer	1	08174
T processor bracket	1	010058
U self tapping bolt;12/24x7/8"	1	07789
V rubber plug; black	2	08162
W grommet;1"odx1/2"idx1/2"thk	1	08064
X hose clamp # 64	1	08648
Y filter charger	1	RF-1040

NOTE: FAILURE TO FOLLOW INSTALLATION INSTRUCTIONS AND NOT USING THE PROVIDED HARDWARE MAY DAMAGE THE INTAKE TUBE, THROTTLE BODY AND ENGINE.

TO START:

1. Turn the ignition OFF and disconnect the vehicle's negative battery cable.



2. Unclip and disconnect the air temperature electrical connection.



3. Pull firmly on the intake tube to separate the intake from the throttle body.



4. Release the two air box lid retaining clips, remove the air box lid and intake tube assembly as shown.



5. Remove the three body support brace mounting bolts shown, then remove the support brace from the engine compartment.

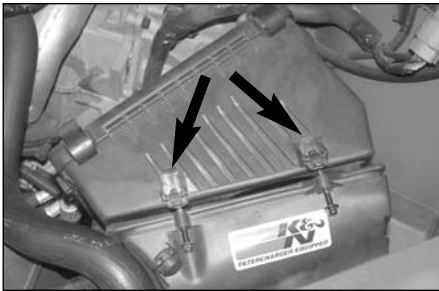

6. Loosen the two air filter housing mounting bolts shown.



7. Tilt the air filter housing in, then lift to remove the filter housing from the mounting tabs.



8. Loosen the center retaining bolts on the engine processor electrical connection and unplug the connectors from the engine processor.

NOTE: The processor electrical connectors are color code to the processor.



9. Remove the engine processor from its housing as shown.



10. Pull firmly up on the engine processor housing to release it from the mounting tabs, then remove the housing from the vehicle.

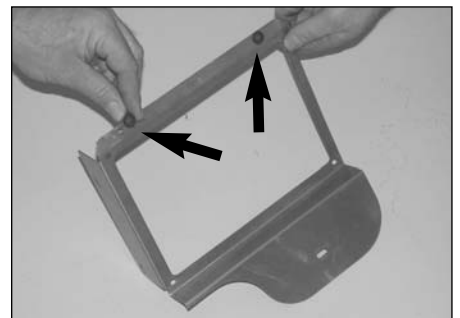

11. Install the rubber bumpers provided into the processor mounting bracket (010058) as shown.



12. Assemble the heat shield to the processor mounting bracket using the provided hardware as shown.



13. Install the small edge trim onto the heat shield assembly as shown.
NOTE: Some trimming may be necessary.

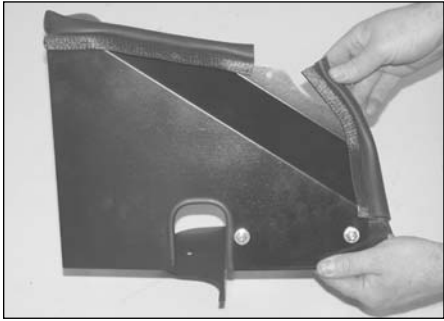

14. Install the large edge trim onto the heat shield as shown.

NOTE: Some trimming of the edge trim may be necessary.



15. Remove the four processor cover plate bolts shown with a #27 Torx socket.



16. Install the engine processor onto the K&N heat shield and mounting bracket as shown.

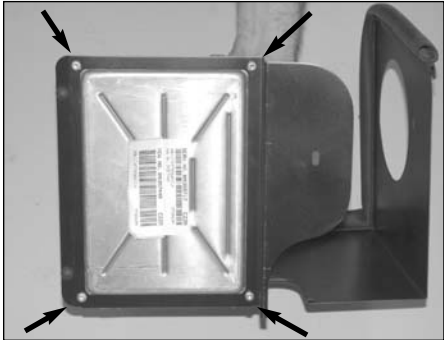

17. Install the four torx bolts remove in step #15 to mount the processor to the mounting bracket.

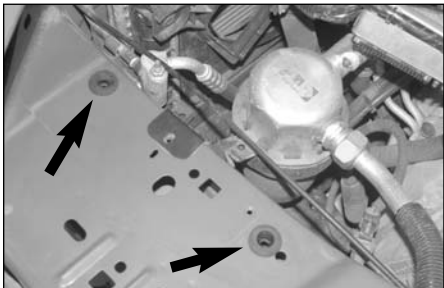

18. Remove the two air box mounting grommets shown by pulling them up out of the holes in the fender apron.

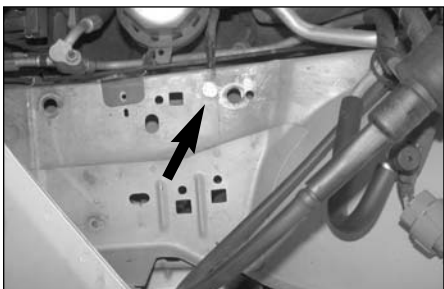

19. Remove the bolt holding the ground strap to the fender apron shown with a 10mm wrench.

NOTE: Some vehicles may not be equipped with this ground strap.



20. On vehicles that do not come equipped with a ground strap, use the 6mm self-tapping bolt to thread the hole shown.

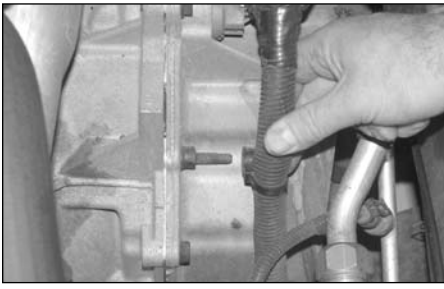

21. Remove the wiring harness retaining clip from stud protruding from the transmission case as shown.



22. Install the K&N tube mounting bracket (07199) onto the stud exposed in step #21 and secure with the hardware provided.

NOTE: Do not tighten at this time.



23. Set the heat shield assembly into position on the fender apron as shown.

NOTE: It will be necessary to route the engine wiring harness through the heat shield during installation.



24. Reinstall the engine wiring harness connectors onto the engine processor and secure with mounting bolts.

NOTE: The processor electrical connectors are color code to the processor.



25. Install the heat shield mounting bracket (010057) using the provided hardware as shown.

NOTE: On vehicles equipped with a ground strap. Reattach the ground strap to the bolt that secures the bottom of the mounting bracket.



26. Remove the radiator mounting bolt and bracket shown.



27. Place the K&N bracket (010056) behind the factory radiator bracket as shown.

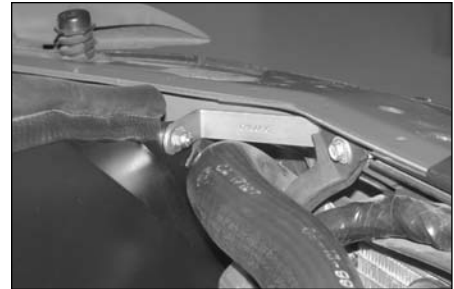

28. Reinstall the factory radiator bracket onto its original location with the K&N bracket (010056) so that the K&N bracket meets with the heat shield assembly and secure with the provided hardware.



29. Install the silicone hose (08621) onto the throttle body and secure with the provided hardware as shown.



30. Install the provided grommet into the K&N intake tube as shown.



31. Remove the air temperature sensor from the factory intake tube.



32. Install the air temperature sensor into the K&N intake tube as shown.



33. Install the K&N intake tube onto the throttle body, securing with the hose clamp provided, then secure the tube to the mounting bracket installed in step #22 with the provided 8mm bolt.

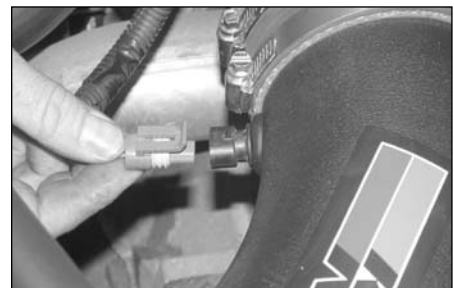

34. Reconnect the air temperature sensor electrical connection.

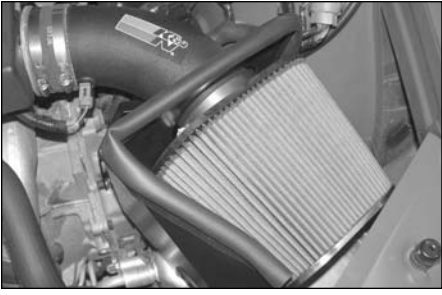

35. Install the K&N filter charger onto the intake tube and secure with the provided hose clamp.



36. Reinstall the body support brace and bolts removed in step #5



37. Reconnect the negative battery cable and double check to make sure everything is tight and properly positioned before starting vehicle.

38. The C.A.R.B. exemption sticker, (attached), must be visible under the hood so that an emissions inspector can see it when the vehicle is required to be tested for emissions. California requires testing every two years, other states may vary.

39. It will be necessary for all FIPK's to be checked periodically for realignment, clearance and tightening of all connections. Failure to follow the above instructions or proper maintenance may void warranty.

ROAD TESTING:

1. Start the engine with the transmission in neutral or park, and the parking brake engaged. Listen for air leaks or odd noises. For air leaks secure hoses and connections. For odd noises, find cause and repair before proceeding. This kit will function identically to the factory system except for being louder and much more responsive.
2. Test drive the vehicle. Listen for odd noises or rattles and fix as necessary.
3. If road test is fine, you can now enjoy the added power and performance from your kit.
4. K&N suggests checking the Filtercharger element periodically for excessive dirt build-up. When the element becomes covered in dirt (or once a year), service it according to the instructions on the Recharger service kit, part number 99-5050 or 99-5000.