



INSTALLATION INSTRUCTIONS

57-3041

CHEVROLET / PONTIAC

1999-02 Camaro / Firebird

V6-3.8L

NOTE: This kit was not designed to fit vehicles with a body lift.

TOOLS NEEDED:

- Flat Blade Screwdriver
- Ratchet
- Extension
- 10mm Socket

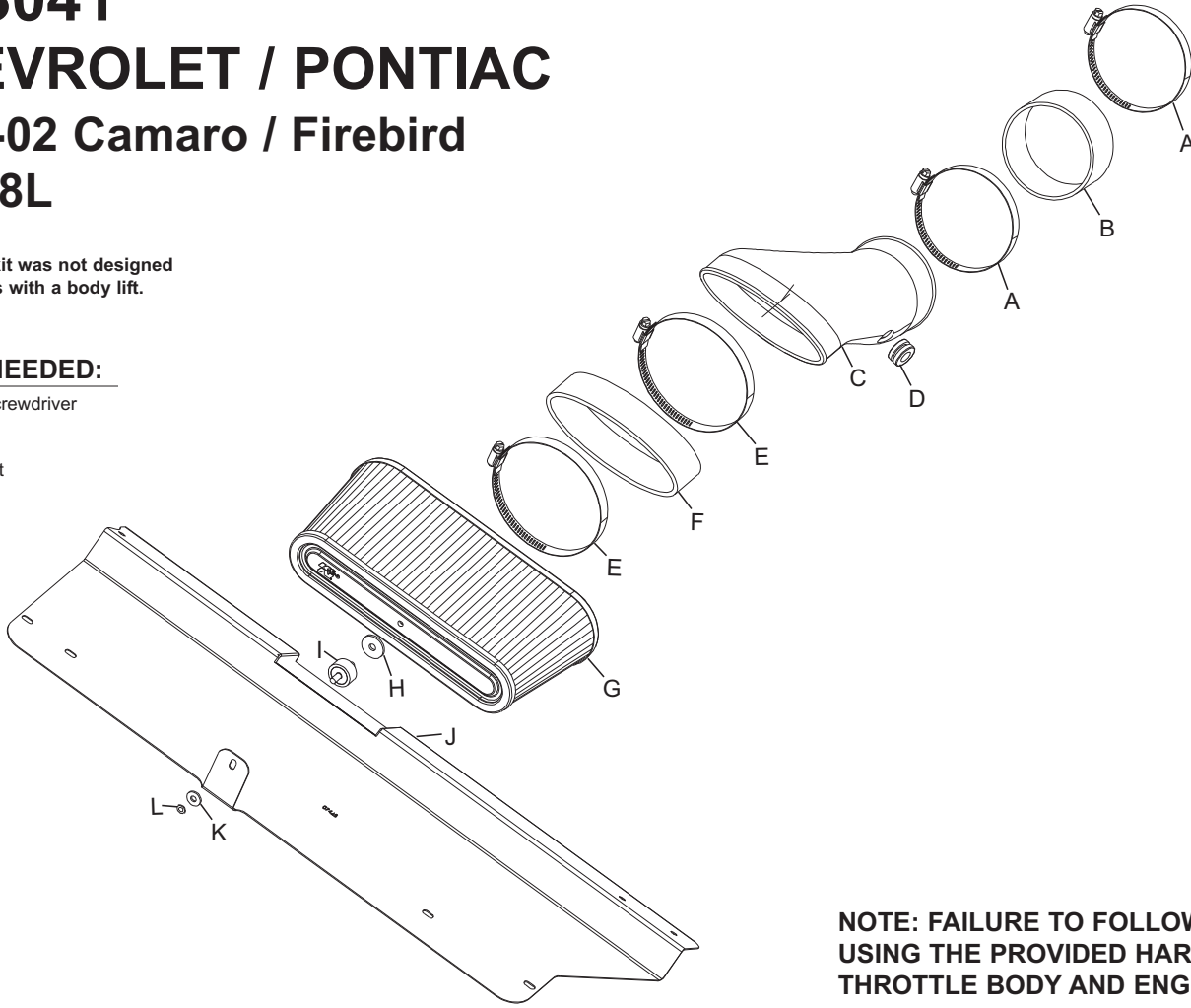

PARTS LIST:

Desc.	QTY.	Part #
A hose clamp; #60	2	08624
B hose; 3.75" id x 1.75" L silicone	1	08621
C intake tube (DI)	1	087104
D grommet; 1/2" id x 1.0" od x 1/2" thk	1	08064
E hose clamp; #72	2	08671
F hose; 2" id x 6.13" id oval	1	08541
G filter	1	RP-5105
H washer; 1" X .300" X .100" rubber	1	21685
I stud; m6/m6 rubber mntd	1	07027
J heat shield	1	07425
K washer; 1/4" id X 5/8" od	1	08275
L nut; m6 nylock	1	07553

NOTE: FAILURE TO FOLLOW INSTALLATION INSTRUCTIONS AND NOT USING THE PROVIDED HARDWARE MAY DAMAGE THE INTAKE TUBE, THROTTLE BODY AND ENGINE.

TO START:

1. Turn the ignition OFF and disconnect the vehicle's negative battery cable.

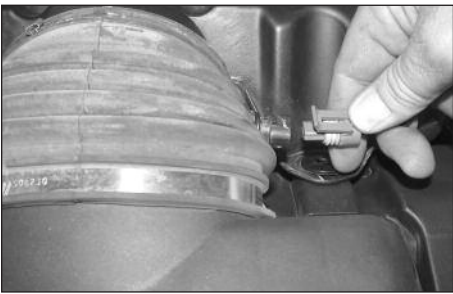

2. Disconnect the air temp sensor electrical connection.

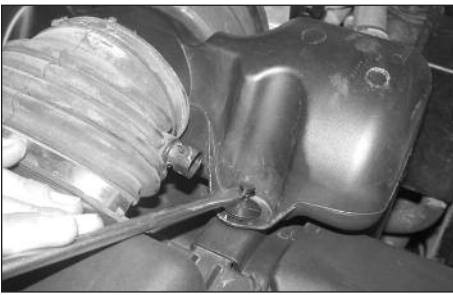

3. Pry up on the two tabs to release the clip that retains the resonator to the radiator cover.



4. Release the two clips that retain the air box top to the air box base.



5. Remove intake from throttle body, then remove the entire upper air intake assembly.



6. Loosen and remove the four bolts that retain the air box base to the radiator core support, then remove the lower air box assembly.



7. Remove the two rubber cushions from the air box base.



8. Install the rubber cushion onto the heat shield as shown.



9. Secure the heat shield to the radiator core support using the bolts removed in step #6.



10. Install the provided silicone hose (08621) onto the throttle body with the provided hose clamps.



11. Install the grommet into the K&N intake tube as shown.



12. Remove the temp sensor from the factory air box as shown.



13. Install the temp sensor into the K&N intake tube as shown.



14. Attach the oval silicone hose (08541) onto the filter as shown.



15. Install the K&N intake tube onto the filter charger as shown.



16. Install the rubber mounted stud into the threaded hole on the top plate of the filter.



17. Install the K&N intake assembly onto the heat shield and throttle body.



18. Align the intake tube for best clearance then tighten hose clamp at the throttle body and secure the filter to heat shield.



19. Reconnect the air temp sensor electrical connection.



29. Reconnect the vehicle's negative battery cable. Double check to make sure everything is tight and properly positioned before starting the vehicle.

30. The C.A.R.B. exemption sticker, (attached), must be visible under the hood so that an emissions inspector can see it when the vehicle is required to be tested for emissions. California requires testing every two years, other states may vary.

31. It will be necessary for all FIPK's to be checked periodically for realignment, clearance and tightening of all connections. Failure to follow the above instructions or proper maintenance may void warranty.

ROAD TESTING:

1. Start the engine with the transmission in neutral or park, and the parking brake engaged. Listen for air leaks or odd noises. For air leaks secure hoses and connections. For odd noises, find cause and repair before proceeding. This kit will function identically to the factory system except for being louder and much more responsive.

2. Test drive the vehicle. Listen for odd noises or rattles and fix as necessary.

3. If road test is fine, you can now enjoy the added power and performance from your kit.

4. K&N suggests checking the Filtercharger element periodically for excessive dirt build-up. When the element becomes covered in dirt (or once a year), service it according to the instructions on the Recharger service kit, part number 99-5050 or 99-5000.