



INSTALLATION INSTRUCTIONS

57-3036

CHEVROLET / GMC / OLDSMOBILE

2002-05 Trailblazer / Envoy

2002-04 Bravada

L6-4.2L

NOTE: This kit was not designed to fit vehicles with a body lift.

TOOLS NEEDED:

- Flat blade screwdriver
- Ratchet
- 10mm socket
- 4mm allen wrench
- 5mm allen wrench
- Phillips screwdriver
- Medium extension
- Drill
- 1-1/4 Hole Saw

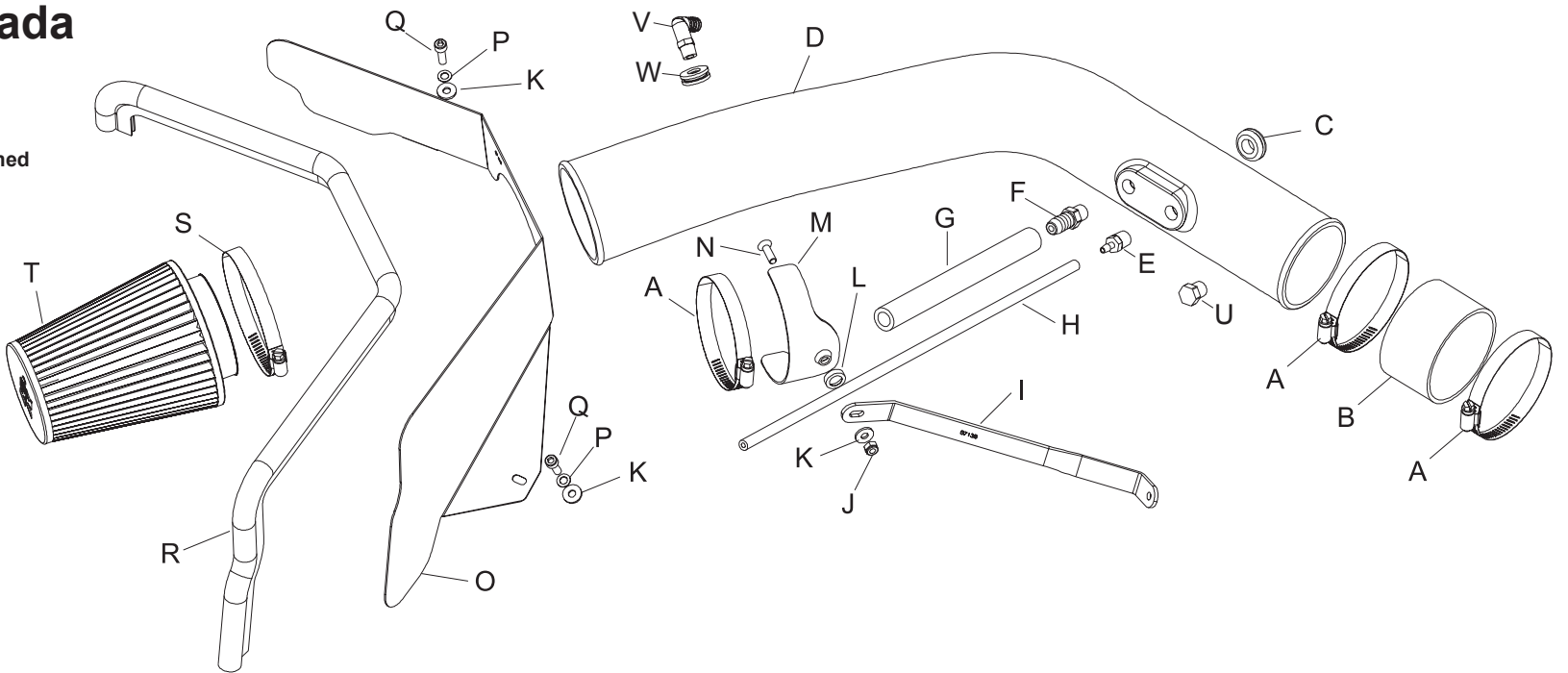

PARTS LIST:

| Description | Qty. | Part # | Description | Qty. | Part # | Description | Qty. | Part # |
|-------------------------------------|------|--------|-------------------------------|------|--------|-------------------|------|---------|
| A Hose clamp #52 | 3 | 08610 | I Bracket | 1 | 07138 | Q 6mm allen head | 2 | 07852 |
| B Silicone hose, 3.25"idx x2"l | 1 | 08690 | J Nut 6mm nylock hexhead | 1 | 07553 | R Edge trim, 32"L | 1 | 102493 |
| C Grommet;1-1/16"od,1/2"id,3/8"thk | 1 | 080544 | K Washer 1/4"idx5/8"od - sae | 3 | 08275 | S Hose clamp #60 | 1 | 08624 |
| D Intake tube (CG) | 1 | 087056 | L Washer, conical, black | 1 | 08180 | T Air Filter | 1 | RC-4630 |
| E Vent str. 3/16 hose, 1/4npt nylon | 1 | 080021 | M Saddle bracket | 1 | 078855 | U Plug | 1 | 08032 |
| F Vent str. 1/2 hose, 1/4npt plas | 1 | 080022 | N Bolt 6mm-1.00x20mm f/h/a ss | 1 | 08376 | V Vent 90 Degree | 1 | 08986 |
| G Silicone hose, 1/2"idx8"l | 1 | 08535 | O Heat shield | 1 | 07468 | W Grommet | 1 | 082000 |
| H Hose; 18", 4mm | 1 | 08153 | P Wave washer 6mm | 2 | 08174 | | | |

NOTE: FAILURE TO FOLLOW INSTALLATION INSTRUCTIONS AND NOT USING THE PROVIDED HARDWARE MAY DAMAGE THE INTAKE TUBE, THROTTLE BODY AND ENGINE.

TO START:

1. Turn off the ignition and disconnect the negative battery cable.
NOTE: Disconnecting the negative battery cable erases pre-programmed electronic memories. Write down all memory settings before disconnecting the negative battery cable. Some radios will require an anti-theft code to be entered after the battery is reconnected. The anti-theft code is typically supplied with your owner's manual. In the event your vehicles anti-theft code cannot be recovered, contact an authorized dealership to obtain your vehicles anti-theft code.

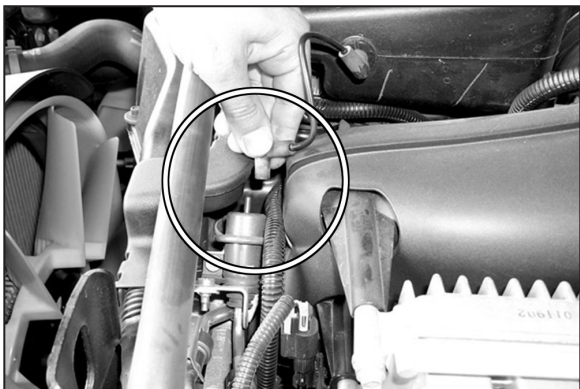

2. On vehicles equipped with a fuel pressure regulator vent, disconnect the vent hose from the fuel pressure regulator as shown.

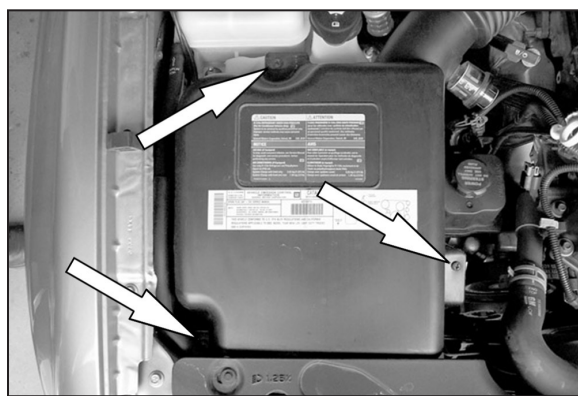

3. Loosen and remove the three screws that retain the upper airbox cover.



4. Remove the upper airbox cover from vehicle as shown.



5. Remove the fresh air supply tube from vehicle.



5a. On vehicles with air injection squeeze release ring then remove air injection line from intake tube.



6. Loosen hose clamp at intake resonator then remove complete air intake tube.

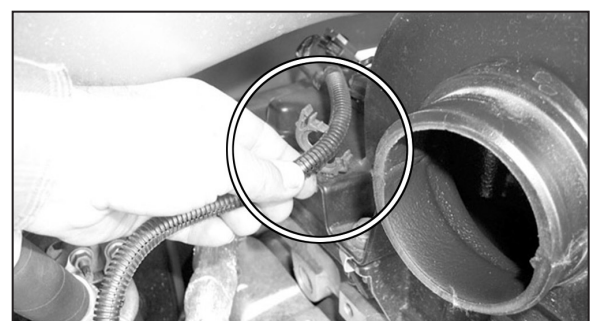

7. Disconnect the clip that holds the air temp. electrical connection wiring loom then remove the wire loom.

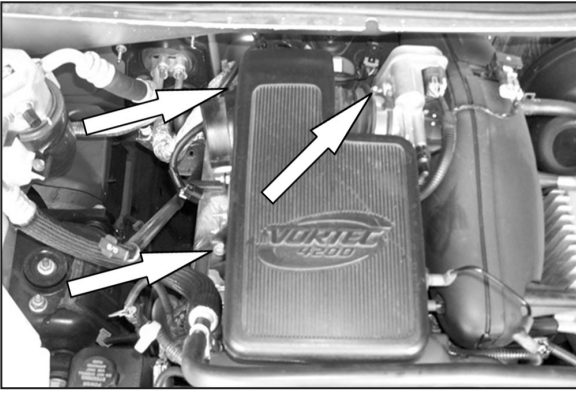

8. Loosen the two bolts that retain the intake resonator and then loosen the hose clamp at the throttle body.



9. Remove the intake resonator from vehicle as shown.

NOTE: Disconnect the crankcase vent while removing the resonator from vehicle.

NOTE: K&N recommends that customer do not discard their factory air intake.



10. Install edge trim onto the heat shield as shown. Trim if needed.

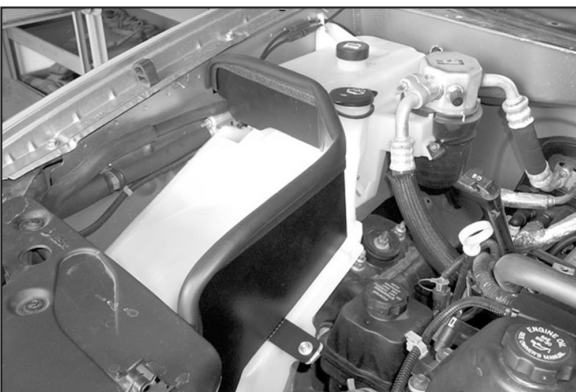

11. Install heat shield into vehicle using the hardware provided.



12. Assemble the saddle bracket assembly as shown.

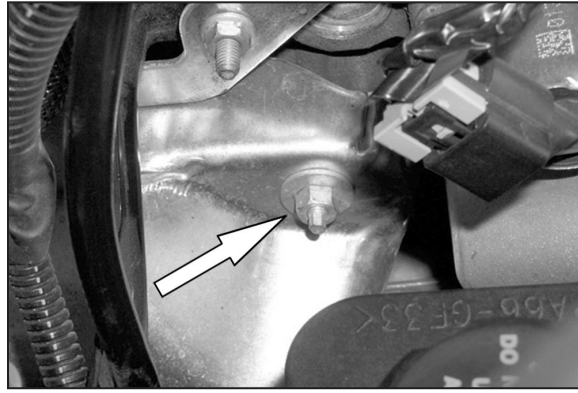

13. Remove the nut that secures the exhaust heat shield to cylinder head as shown.



14. Using the nut that was removed in the previous step, install the saddle bracket as shown.



15. Install the silicone hose onto the throttle body with the provided hose clamps.



16. Install the provided vent fittings onto the K&N® intake tube as shown.



16a. On vehicles not equipped with a fuel pressure regulator vent use the npt pipe plug provided in place of the 3/16" barbed fitting.

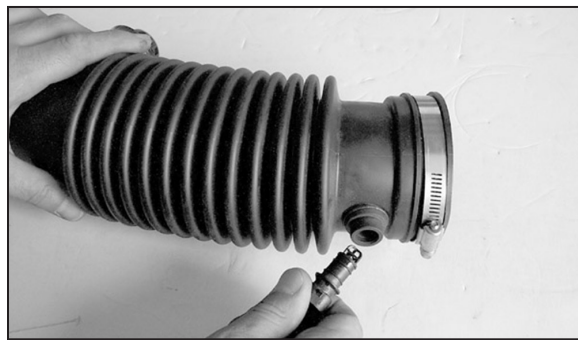

17. Remove the air temp sensor from stock intake tube as shown.



18. Install the provided grommet onto the new K&N® intake tube as shown.



19. Install the air temp sensor into the new K&N® intake tube as shown.



20. Install the new K&N® intake tube into the vehicle and tightening hose clamp at the throttle body and at the saddle bracket as shown.



20a. On vehicles with air injection cut the vent hose 1" from end of hose.



20b. On vehicles with air injection install the 90 degree fitting into the vent line then mark the intake tube where the fitting lines up with tube, then remove intake tube from vehicle.



20c. Use a 1-1/4 hole saw and drill a hole where the intake tube was marked in the previous step. Then install the provided grommet as shown.



20d. Re-install the intake tube onto the vehicle, then install the 90 degree fitting into the grommet on the intake tube as shown.

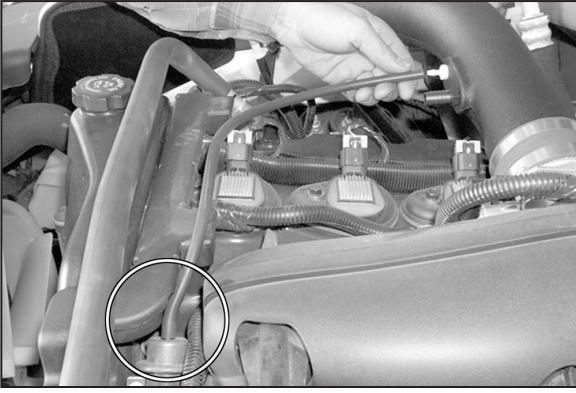

21. On Vehicles equipped with a fuel pressure regulator vent hose, install the provided 4mm silicone hose onto the K&N® intake tube and the other end onto the fuel pressure regulator vent as shown.

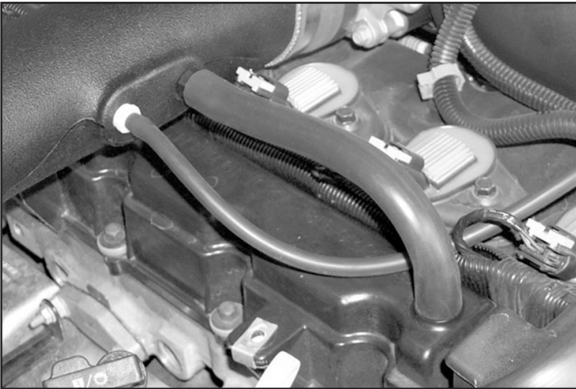

22. Install the 1/2" silicone hose onto the K&N® intake tube and the other end onto the crankcase vent as shown.

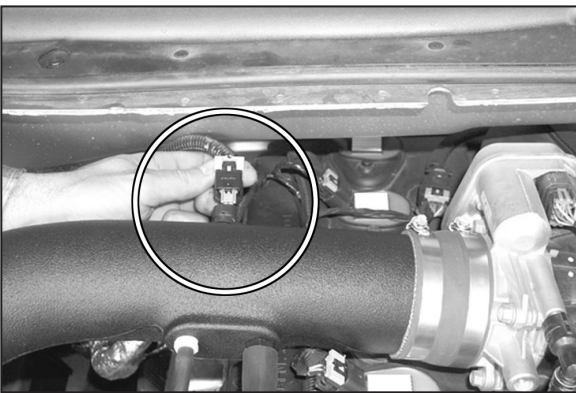

23. Reconnect the air temp. electrical connection as shown.



24. Install the K&N® Air Filter onto the K&N® intake tube as shown.



25. Reconnect the vehicle's negative battery cable. Double check to make sure everything is tight and properly positioned before starting the vehicle.

26. The C.A.R.B. exemption sticker, (attached), must be visible under the hood so that an emissions inspector can see it when the vehicle is required to be tested for emissions. California requires testing every two years, other states may vary.

27. Most General Motors trucks vehicles have the Vehicle Emissions Certification Information (VECI) label affixed to the air filter box. In order to be compliant with California emissions laws, the label MUST remain in the engine compartment. If the Vehicle Emission Control Information label is removed during modification, a new replacement label must be obtained and installed in a readily visible position in the engine compartment. The label shall not be affixed to any equipment which is easily detached from the vehicle. We recommend that the label is affixed to the underside of the hood adjacent to the hood latch. The label is Vehicle Identification Number dependent and can be ordered from the vehicle dealership. In order to receive the proper decal please bring your VIN with you. Failure to have the VECI under the hood may result in failure of a pre-registration smog test.

28. It will be necessary for all K&N® high flow intake systems to be checked periodically for realignment, clearance and tightening of all connections. Failure to follow the above instructions or proper maintenance may void warranty.

ROAD TESTING:

1. Start the engine with the transmission in neutral or park, and the parking brake engaged. Listen for air leaks or odd noises. For air leaks secure hoses and connections. For odd noises, find cause and repair before proceeding. This kit will function identically to the factory system except for being louder and much more responsive.

2. Test drive the vehicle. Listen for odd noises or rattles and fix as necessary.

3. If road test is fine, you can now enjoy the added power and performance from your kit.

4. K&N Engineering, Inc., requires cleaning the intake system's air filter element every 100,000 miles. When used in dusty or off-road environments, our filters will require cleaning more often. We recommend that you visually inspect your filter once every 25,000 miles to determine if the screen is still visible. When the screen is no longer visible some place on the filter element, it is time to clean it. To clean and re-oil, purchase our filter Recharger® service kit, part number 99-5050 or 99-5000 and follow the easy instructions.