



# FUEL INJECTION PERFORMANCE KIT FIPK

## INSTALLATION INSTRUCTIONS

### 57-3028 CHEVROLET/GMC 1988-93 S10/S15 V6-4.3L - TBI

NOTE: This kit was not designed to fit vehicles with a body lift.

#### TOOLS NEEDED:

Flat Blade Screwdriver  
10mm Wrench

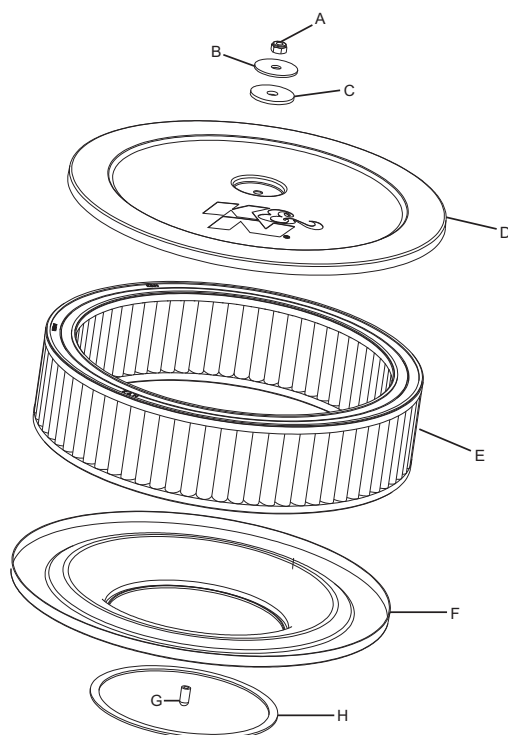

#### PARTS LIST:

Desc.	QTY.	Part #
A nut; 6mm nylock, hexhead	1	07553
B washer; 1.25d x .28 hol	1	08151
C washer; 1.25 x .30 x .10 rubber	1	21708
D top plate 11"d ss 1/8 dp/ct	1	06801
E filtercharger element	1	E-1240
F bottom plate 11"d cr 5-1/8 flg	1	01988
G caplug; 11/64" id, 1/2" l, grey	1	08116
H gasket	1	09988

#### TO START:



1. Turn the ignition OFF and disconnect the vehicle's negative battery cable.



2. Loosen and remove the wing nut on the air cleaner lid, then remove the air cleaner lid.



3. Loosen and remove the screw that retains the air inlet tube.



4. Remove the complete [air intake](#) assembly.



5. On vehicles equipped with a vacuum operated heat stove flapper door, use the supplied vinyl plug on the throttle body vacuum port.



6. Remove the stock paper gasket from the air cleaner spacer, and replace it with the provided rubber gasket as shown.



7. Install the base plate on the throttle body.



8. Install the K&N Filtercharger onto the base plate as shown.



9. Install the top plate onto the filter assembly as shown.



10. Using the provided hardware, secure the air cleaner assembly as shown.



11. Reconnect the vehicle's negative battery cable. Double check to make sure everything is tight and properly positioned before starting the vehicle.

12. The C.A.R.B. exemption sticker, (attached), must be visible under the hood so that an emissions inspector can see it when the vehicle is required to be tested for emissions. California requires testing every two years, other states may vary.

13. It will be necessary for all FIPK's to be checked periodically for realignment, clearance and tightening of all connections. Failure to follow the above instructions or proper maintenance may void warranty.

#### ROAD TESTING:

1. Start the engine with the transmission in neutral or park, and the parking brake engaged. Listen for air leaks or odd noises. For air leaks secure hoses and connections. For odd noises, find cause and repair before proceeding. This kit will function identically to the factory system except for being louder and much more responsive.

2. Test drive the vehicle. Listen for odd noises or rattles and fix as necessary.

3. If road test is fine, you can now enjoy the added power and performance from your kit.

4. K&N suggests checking the Filtercharger element periodically for excessive dirt build-up. When the element becomes covered in dirt (or once a year), service it according to the instructions on the Recharger service kit, part number 99-5050 or 99-5000.

**50-STATE STREET LEGAL  
K&N CARB EXEMPT K&N**