



## INSTALLATION INSTRUCTIONS

57-3022-2

CHEVROLET / PONTIAC

1998-02 Camaro / Firebird

V8-5.7L

### TOOLS NEEDED:

Flat Blade Screwdriver  
Ratchet  
Socket Extension  
10mm Socket  
Utility Knife  
7/16 Wrench

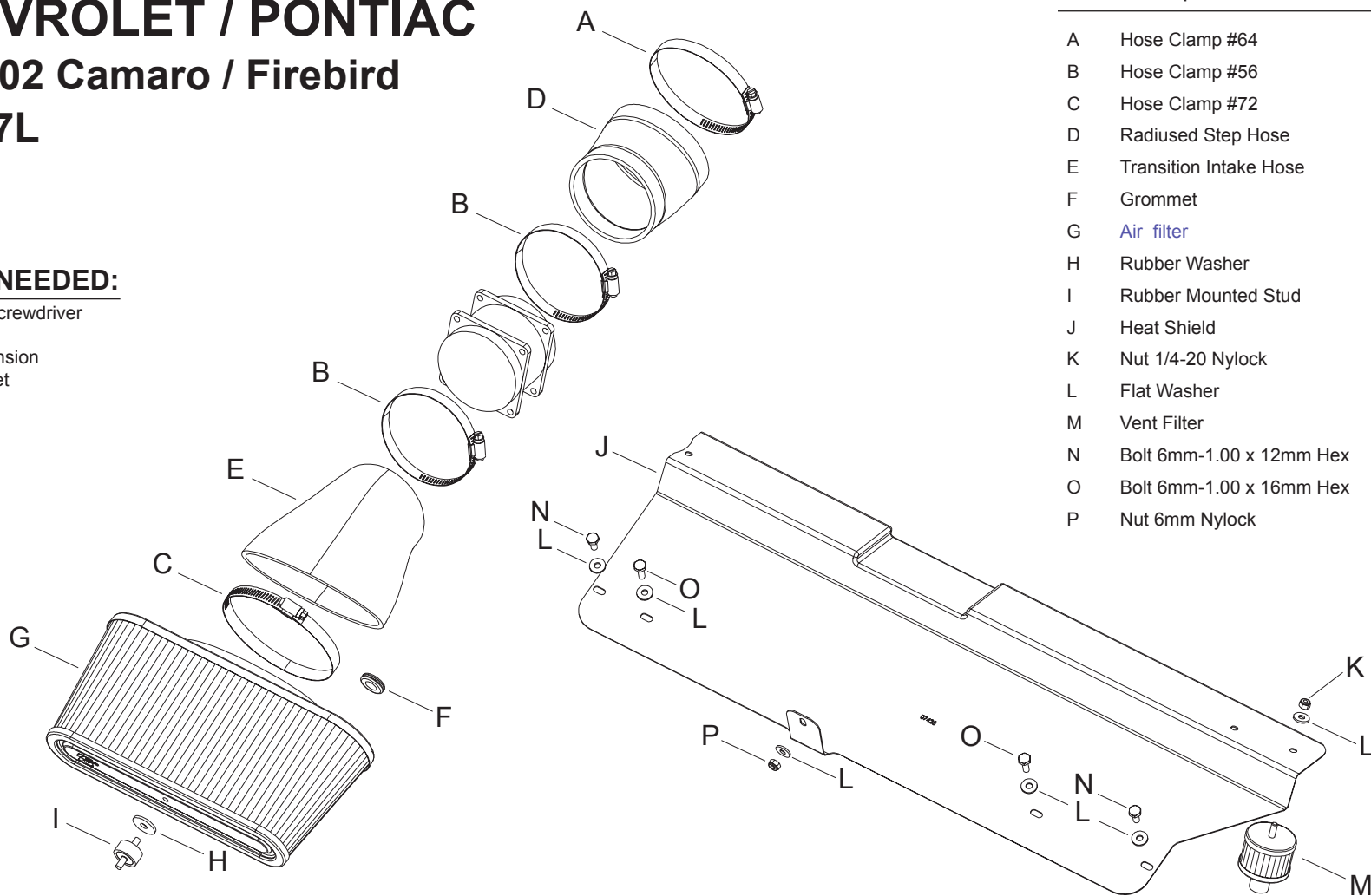

### PARTS LIST:

	Description	Qty.	Part #
A	Hose Clamp #64	1	08648
B	Hose Clamp #56	2	08620
C	Hose Clamp #72	1	08671
D	Radiused Step Hose	1	08749
E	Transition Intake Hose	1	08746
F	Grommet	1	08167
G	Air filter	1	RF-1050
H	Rubber Washer	1	21685
I	Rubber Mounted Stud	1	07027
J	Heat Shield	1	07425
K	Nut 1/4-20 Nylock	1	07517
L	Flat Washer	6	08275
M	Vent Filter	1	62-1120
N	Bolt 6mm-1.00 x 12mm Hex	2	07863
O	Bolt 6mm-1.00 x 16mm Hex	2	07703
P	Nut 6mm Nylock	1	07553

**NOTE: FAILURE TO FOLLOW INSTALLATION INSTRUCTIONS AND NOT USING THE PROVIDED HARDWARE MAY DAMAGE THE INTAKE TUBE, THROTTLE BODY AND ENGINE.**

### TO START:

1. Turn off the ignition and disconnect the negative battery cable.

**NOTE: Disconnecting the negative battery cable erases pre-programmed electronic memories. Write down all memory settings before disconnecting the negative battery cable. Some radios will require an anti-theft code to be entered after the battery is reconnected. The anti-theft code is typically supplied with your owner's manual. In the event your vehicles' anti-theft code cannot be recovered, contact an authorized dealership to obtain your vehicles anti-theft code.**

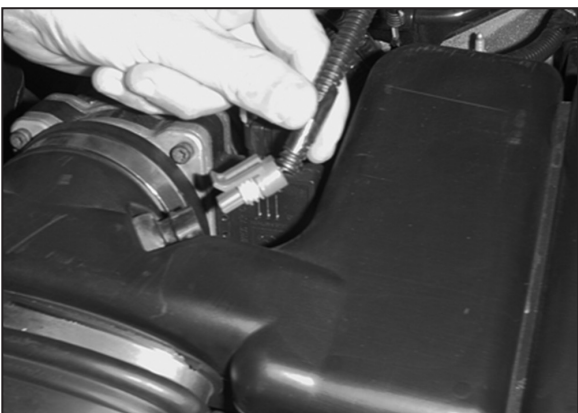

2. Disconnect the air temperature sensor electrical connection.

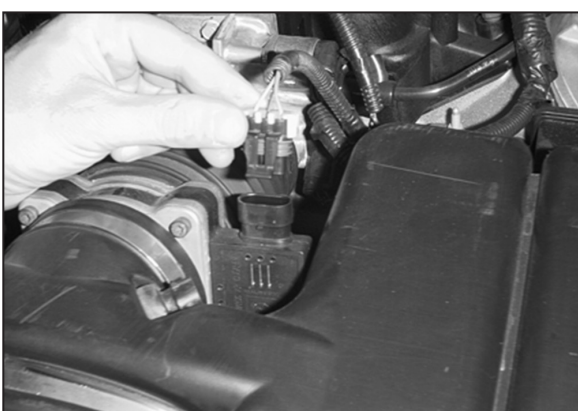

3. Disconnect the mass-air sensor.

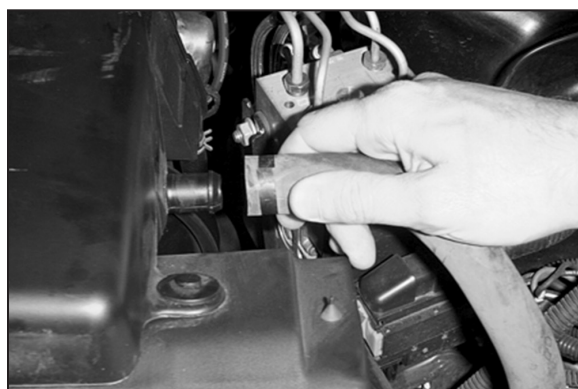

4. On models equipped with air injection, detach the air injection hose from the resonator.



5. Pry up on tab to release the clip that retains the resonator to the radiator cover.

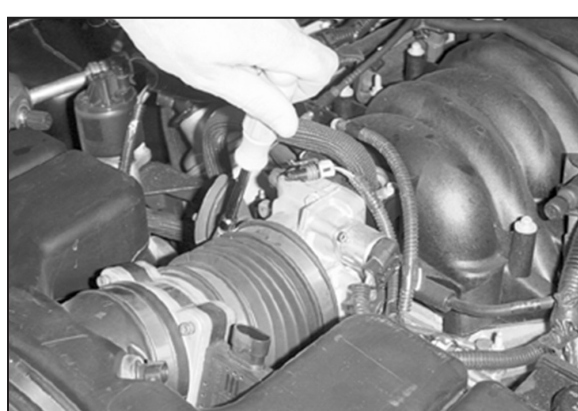

6. Loosen the hose clamp on the intake hose at the throttle body.



7. Release the two clips that retain the air box top to the air box base.



8. Detach the intake hose from the throttle body and remove the entire upper air intake assembly.



9. Loosen and remove the 4 bolts that retain the air box base to the radiator core support, then remove the lower air box assembly.

**NOTE: K&N Engineering, Inc., recommends that customers do not discard factory air intake.**

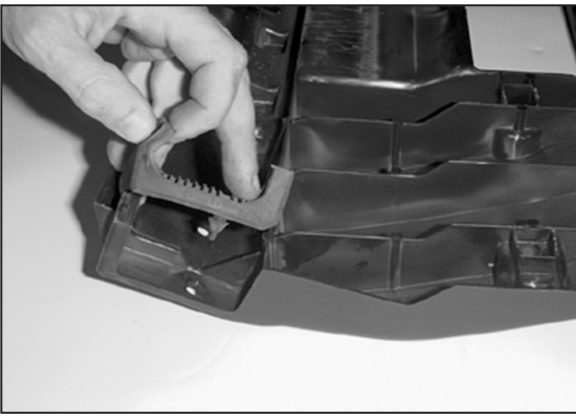

10. Remove the two rubber cushions from the air box base.



11. Install the rubber cushions onto the heat shield as shown.

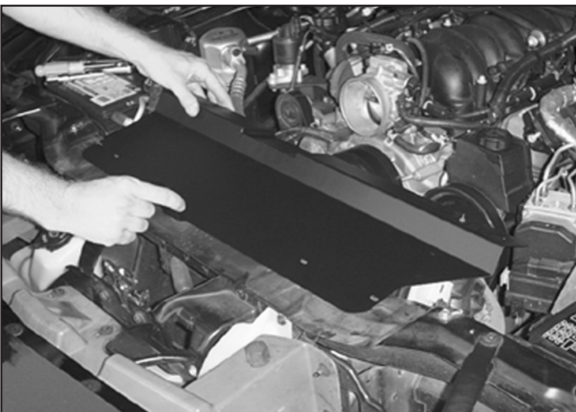

12. Install the heat shield assembly.

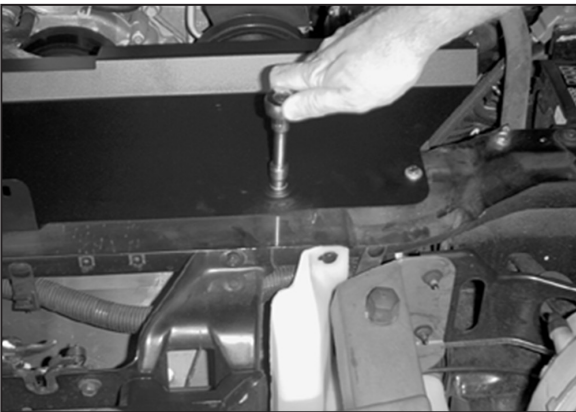

13. Secure the heat shield to the radiator core support using the hardware provided.

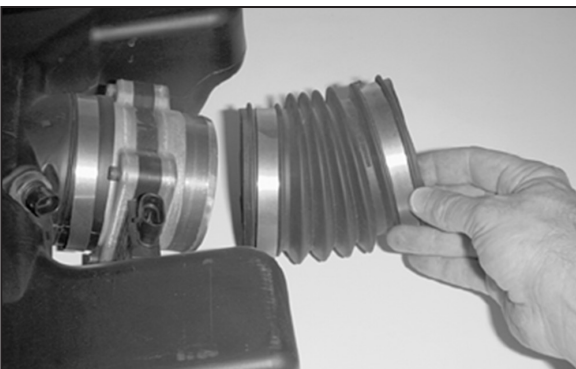

14. Loosen the hose clamp on the intake hose at the mass air sensor then detach the hose from the mass air sensor.

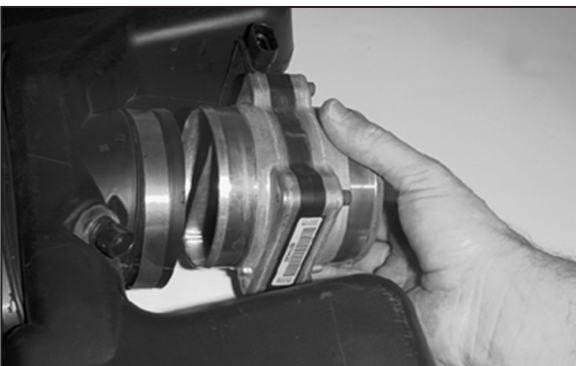

15. Loosen the hose clamp on the flange of the air box and remove the mass air sensor.



16. Remove the air temp sensor from the resonator.

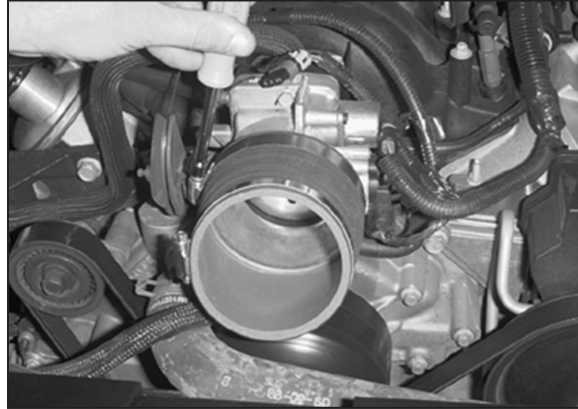

17. Attach the silicone hose to the throttle body.  
**Note: Do not tighten the hose clamp completely at this time.**

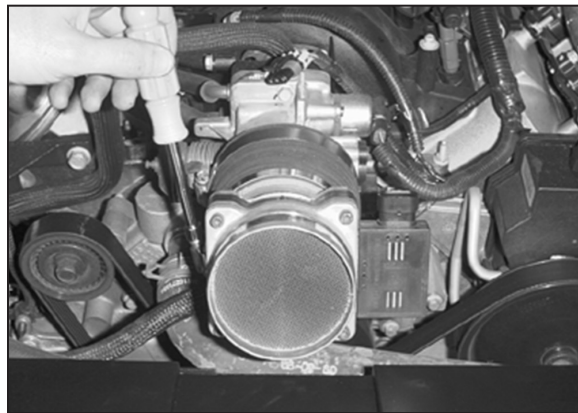

18. Install the mass air sensor into the silicone hose and tighten hose clamp.

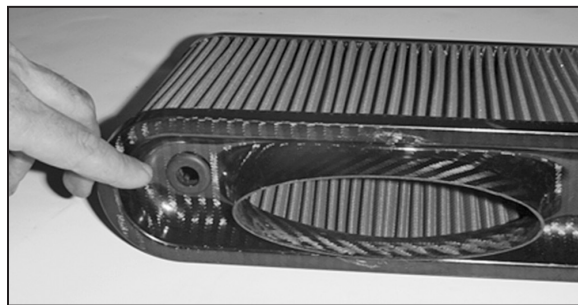

19. Install the grommet into the small hole in the air filter.



20. Insert the air temp sensor into the grommet.



21. Install the rubber mounted stud into the threaded hole on the top plate of the filter.



22. Attach the round oval silicone hose on to the flange of the filter.

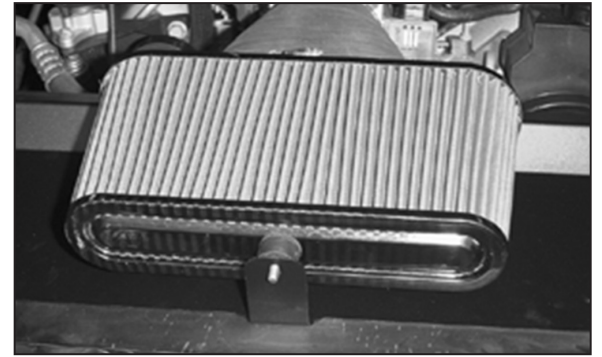

23. Install the air filter assembly attaching the silicone hose to the mass air sensor.



24. Secure the rubber mounted stud to the flap on the heat shield using the hardware provided.

25. Align everything for best clearance and tighten all hose clamps and hardware.



26. On models equipped with air injection, oil the vent filter provided.



27. On models equipped with air injection, attach the vent filter to the heat shield using the hardware provided.



28. On models with air injection, align the air injection vent hose with the flange of the vent filter and mark.



29. On models with air injection, cut the air injection vent hose at the mark.



30. On models with air injection, attach the air injection hose to the flange on the vent filter using the O.E. clamp.

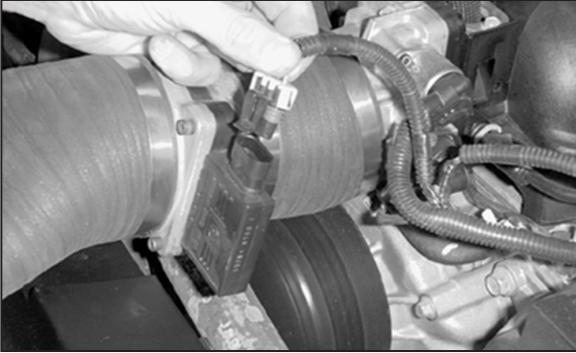

31. Reconnect the mass air electrical connection.



32. Reconnect the air temperature sensor electrical connection.

33. Reconnect the vehicle's negative battery cable. Double check to make sure everything is tight and properly positioned before starting the vehicle.

34. The C.A.R.B. exemption sticker, (attached), must be visible under the hood so that an emissions inspector can see it when the vehicle is required to be tested for emissions. California requires testing every two years, other states may vary.

35. It will be necessary for all K&N® high flow intake systems to be checked periodically for realignment, clearance and tightening of all connections. Failure to follow the above instructions or proper maintenance may void warranty.

#### ROAD TESTING:

1. Start the engine with the transmission in neutral or park, and the parking brake engaged. Listen for air leaks or odd noises. For air leaks secure hoses and connections. For odd noises, find cause and repair before proceeding. This kit will function identically to the factory system except for being louder and much more responsive.

2. Test drive the vehicle. Listen for odd noises or rattles and fix as necessary.

3. If road test is fine, you can now enjoy the added power and performance from your kit.

4. K&N Engineering, Inc., requires cleaning the intake system's air filter element every 100,000 miles. When used in dusty or off-road environments, our filters will require cleaning more often. We recommend that you visually inspect your filter once every 25,000 miles to determine if the screen is still visible. When the screen is no longer visible some place on the filter element, it is time to clean it. To clean and re-oil, purchase our filter Recharger® service kit, part number 99-5050 or 99-5000 and follow the easy instructions.