



INSTALLATION INSTRUCTIONS

57-2578

FORD

2011-14 Mustang

V8-5.0L

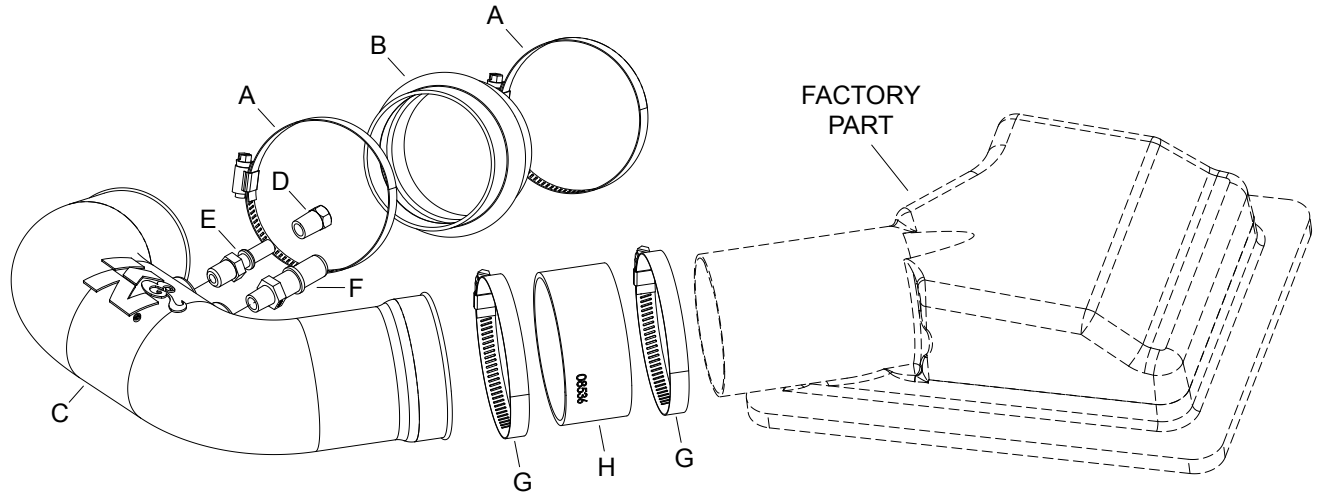

TOOLS NEEDED:

flat blade screw driver
ratchet
13mm socket
pliers
3/4" wrench
5/8" wrench

PARTS LIST:

Description	Qty.	Part #
A Hose Clamp #56	2	08620
B Hose; 3-1/2" ID X 2-1/2"L Hump	1	08699
C Intake Tube	1	087271
D Plug; 1/4 NPT, Plastic, Black	1	08032
E Vent; STRT, 1/4" NPT To Quick	1	08938
F Vent; 1/4 NPT To Quick	1	082628
G Hose Clamp #60 Stainless	2	08628
H Hose; 3-3/4" ID X 1-3/4"L	1	08536
I Air filter	1	33-2431
J Cap	1	08246

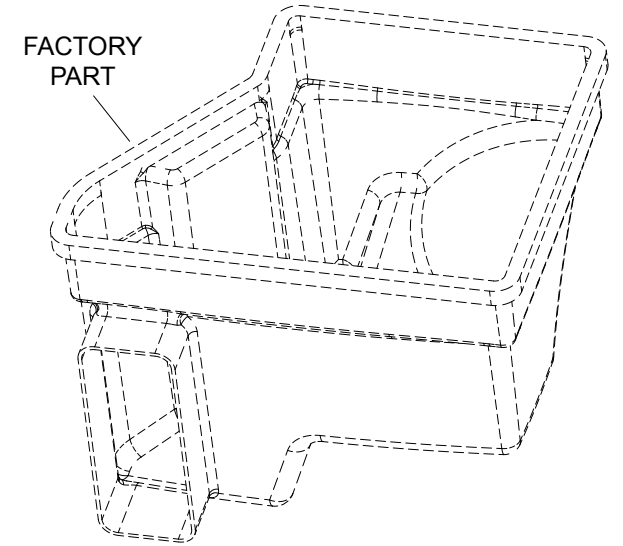
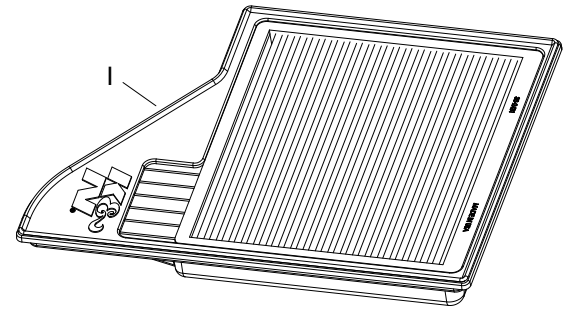

NOTE: FAILURE TO FOLLOW INSTALLATION INSTRUCTIONS AND NOT USING THE PROVIDED HARDWARE MAY DAMAGE THE INTAKE TUBE, THROTTLE BODY AND ENGINE.

TO START:

1. Turn off the ignition and disconnect the negative battery cable.
NOTE: Disconnecting the negative battery cable erases pre-programmed electronic memories. Write down all memory settings before disconnecting the negative battery cable. Some radios will require an anti-theft code to be entered after the battery is reconnected. The anti-theft code is typically supplied with your owner's manual. In the event your vehicles anti-theft code cannot be recovered, contact an authorized dealership to obtain your vehicles anti-theft code.

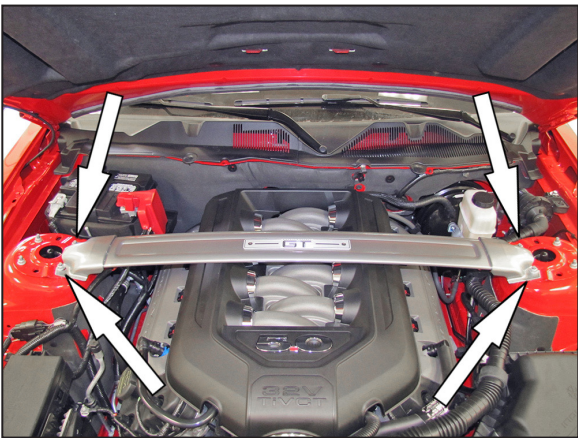

2. Remove the four nuts securing the strut bar and then remove the strut bar from the vehicle.



3. Lift off the decorative engine cover.

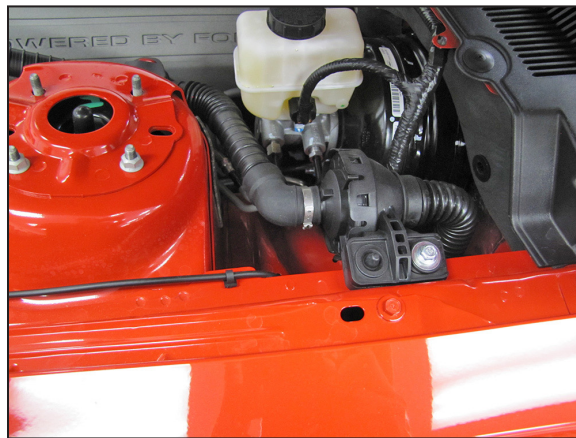

4. Cut the clamp securing the sound tube to the sound drum and then disconnect the sound tube from the drum.

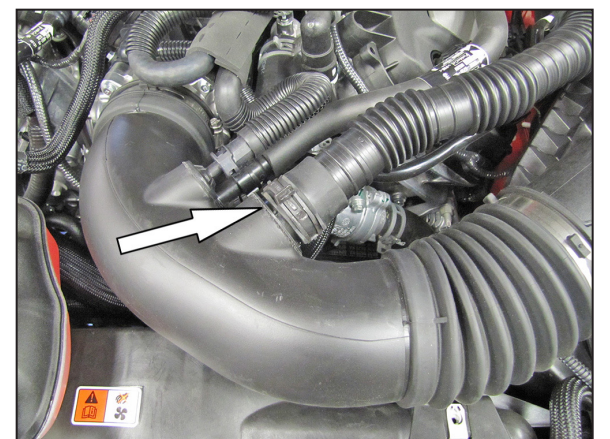

5. Release the spring clamp securing the sound tube to the intake tube and then disconnect the sound tube from the intake tube. Remove the sound tube from the vehicle.



6. Install the provided cap onto the sound drum as shown.

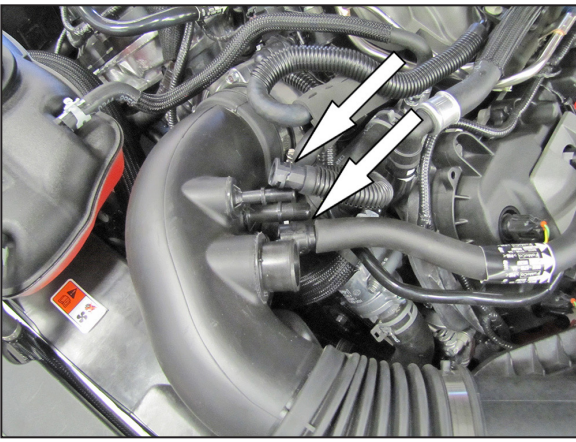

7. On vehicle equipped with an EVAP vent line, disconnect the EVAP vent line from the factory intake tube. Disconnect the crank case vent hose from the factory intake tube.



8. Loosen the hose clamps securing the factory intake tube and remove the intake tube from the vehicle.
NOTE: K&N Engineering, Inc., recommends that customers do not discard factory air intake.

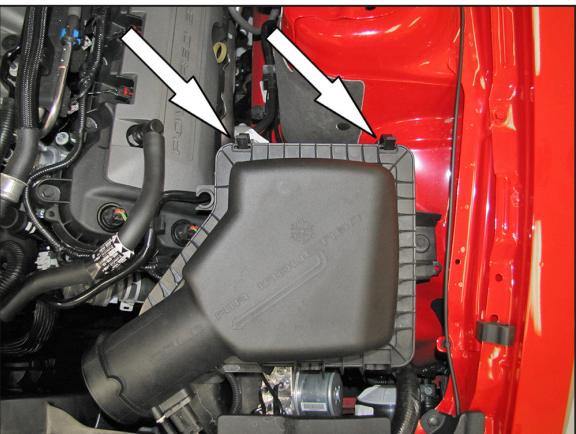

9. Release the air box retaining clips and lift off the upper air box.



10. Remove the factory air filter and replace with the provided K&N® air filter, then reinstall the air box lid.

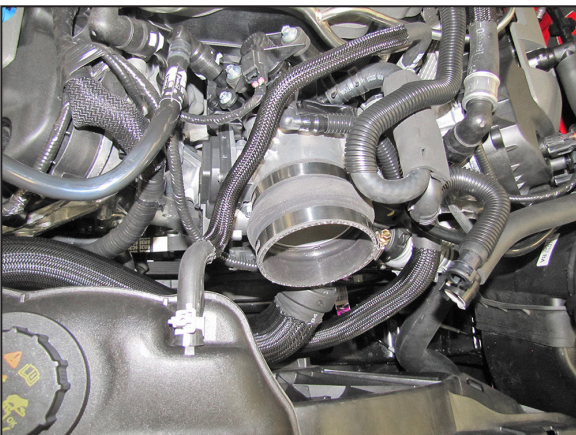

11. Install the provided coupling hose (08699) onto the throttle body and secure with the provided hose clamp.

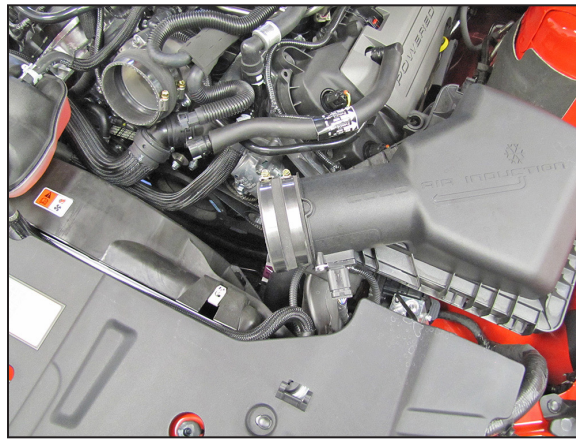

12. Install the provided coupling hose (08536) onto the air box outlet and secure with the provided hose clamp.

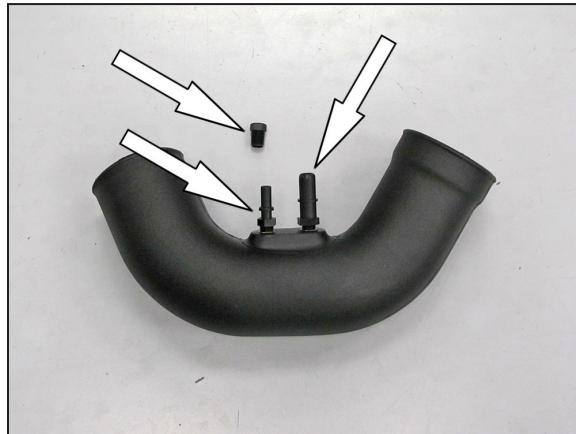

13. Install the provided quick connect fittings into the K&N intake tube as shown.
NOTE: On models that are not equipped with an EVAP vent line, it is necessary to install the 1/4npt plug in place of the small quick connect fitting.
NOTE: Plastic NPT fittings are easy to cross thread. Install the vent fitting "hand" tight, then turn it two complete turns with a wrench.



14. Install the K&N® intake tube into the hose at the air box and then into the hose at the throttle body. Adjust the tube for proper fitment and then secure with the provided hose clamps.

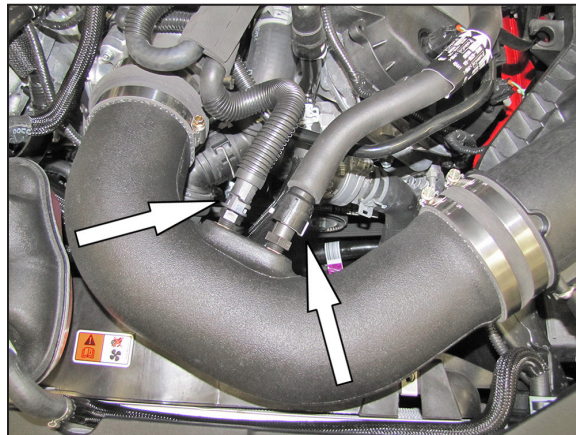

15. Connect the crank case vent hose and EVAP vent hose if equipped to the quick connect fittings as shown.



16. Reinstall the decorative engine cover.



17. Reinstall the strut tower brace and secure with the factory nuts.



18. Reconnect the vehicle's negative battery cable. Double check to make sure everything is tight and properly positioned before starting the vehicle.

19. The C.A.R.B. exemption sticker, (attached), must be visible under the hood so that an emissions inspector can see it when the vehicle is required to be tested for emissions. California requires testing every two years, other states may vary.

20. It will be necessary for all K&N® high flow intake systems to be checked periodically for realignment, clearance and tightening of all connections. Failure to follow the above instructions or proper maintenance may void warranty.

ROAD TESTING:

1. Start the engine with the transmission in neutral or park, and the parking brake engaged. Listen for air leaks or odd noises. For air leaks secure hoses and connections. For odd noises, find cause and repair before proceeding. This kit will function identically to the factory system except for being louder and much more responsive.

2. Test drive the vehicle. Listen for odd noises or rattles and fix as necessary.

3. If road test is fine, you can now enjoy the added power and performance from your kit.

4. K&N Engineering, Inc., requires cleaning the intake system's air filter element every 100,000 miles. When used in dusty or off-road environments, our filters will require cleaning more often. We recommend that you visually inspect your filter once every 25,000 miles to determine if the screen is still visible. When the screen is no longer visible some place on the filter element, it is time to clean it. To clean and re-oil, purchase our filter Recharger® service kit, part number 99-5050 or 99-5000 and follow the easy instructions.